

**TECHNO-ECONOMIC STUDY ON MITIGATION OF  
SOLAR INTERMITTENCY USING BATTERY ENERGY  
STORAGE SYSTEMS**

H. D. K. Herath

168515D

Degree of Master of Science

Department of Electrical Engineering

University of Moratuwa

Sri Lanka

March 2020

**TECHNO-ECONOMIC STUDY ON MITIGATION OF  
SOLAR INTERMITTENCY USING BATTERY ENERGY  
STORAGE SYSTEMS**

H. D. K. Herath

168515D

Thesis/Dissertation submitted in partial fulfillment of the requirements for the degree  
Master of Science in EE

Department of Electrical Engineering

University of Moratuwa  
Sri Lanka

March 2020

## **Declaration, copyright statement and the statement of the supervisor**

I declare that this is my own work and this thesis/dissertation does not incorporate without acknowledgement any material previously submitted for a Degree or Diploma in any other University or institute of higher learning and to the best of my knowledge and belief it does not contain any material previously published or written by another person except where the acknowledgement is made in the text.

Also, I hereby grant to University of Moratuwa the non-exclusive right to reproduce and distribute my thesis/dissertation, in whole or in part in print, electronic or other medium. I retain the right to use this content in whole or part in future works (such as articles or books)

Signature:

Date:

The above candidate has carried out research for the Masters Dissertation under my supervision.

Signature of the supervisor:

Date:

Dr. L.N. Widanagama Arachchige

## **Abstract**

According to the government policies, it has been planned to integrate at least 20% of non-conventional renewable energy (NCRE) by year 2020. Among all these NCRE sources solar power has the lowest capital cost and smallest implementation period. Since solar is an intermittent power source, its output power varies drastically with the cloud cover. This phenomenon results in power system stability issues. With varying power generation, system frequency tends to vary risking the stability of the power system.

In the least cost long term generation expansion plan 2018 – 2037 of Ceylon Electricity Board, it has been proposed to integrate 1,000 MW of solar capacity into the Sri Lankan network by year 2025. Among this, 300 MW will be connected as rooftop solar plants to the low voltage network and the remaining 700 MW will be connected to the medium and high voltage network as 1 MW-10 MW plants or solar parks.

But with the current generation mix, this total solar power isn't be able to absorb to the national grid due to stability issues. Therefore, Battery Energy Storage Systems has been utilized in order to maintain system stability according to the grid code while absorbing 1000 MW of solar power into the system. 150 MW of battery capacity has been required to maintain the frequency stability and could be commissioned as 50 MW each in Kolonnawa, Kappalturei and Hambantota grid substations considering the power loss.

***Keywords:*** *Solar power, Battery Energy Storage Systems, Power system stability, intermittency.*

## **Acknowledgement**

I would like to express my sincere gratitude to my supervisors Dr. Lidula N. Widanagama Arachchige for providing guidance and cordial support throughout my research. Her support and motivation were invaluable driving forces towards me for the successful accomplishment of this study. It is for me a great pleasure and a great experience to having work under such friendly supervisor, who is having a broad scientific knowledge related to my research work. Without her immense encouragement, this study wouldn't be a success.

I am also very grateful to my masters' coordinator Dr. Upuli for her precious advices in progress reviews and thesis preparation by providing useful suggestions.

I would like to gratefully thank Dr. H. M. Wijekoon Banda, Chief Engineer, Transmission and Generation Planning Unit, Ceylon Electricity Board for his precious advices during this research work by providing valuable advices.

Furthermore, I would like to thank my husband Mr. Sajitha Hettiarachchi, for his immense support, encouragement and faith in me and my mother for her heartiest blessings which made this work a success. Also, I'm grateful for my colleagues, friends and everybody who has supported me throughout the entire process, both by keeping me harmonious and helping me putting pieces together.

H. D. K Herath

## Table of Contents

Declaration, copyright statement and the statement of the supervisor.....	i
Abstract .....	ii
Acknowledgement.....	iii
Table of Contents .....	iv
List of Figures .....	vi
List of Tables.....	viii
CHAPTER 1 .....	1
INTRODUCTION .....	1
1.1 Present Sri Lankan Power System.....	1
1.2 Problem Statement .....	1
1.3 Research Objectives and goal.....	3
1.4 Thesis Overview .....	4
CHAPTER 2 .....	5
LITERATURE REVIEW.....	5
2.1 Power System Stability .....	5
2.2 Energy Storage Systems (ESS) .....	6
2.3 Battery Energy Storage Systems .....	10
2.4 Levelized Cost of Energy (LCOE) and Levelized Cost of Energy Storage (LCOES) .....	14
CHAPTER 3 .....	16
TRANSMISSION MODEL VALIDATION .....	16
3.1 Power System dynamic modeling in PSS/E.....	19
3.2 Sri Lankan power system validation .....	21

CHAPTER 4 .....	26
SOLAR MODEL VALIDATION.....	26
4.1 Steady state solar model validation .....	29
4.2 Dynamic model validation .....	31
4.3 Solar model validation for Hambantota 10 MW solar plant .....	34
CHAPTER 5 .....	41
BATTERY ENERGY STORAGE SIZING.....	41
CHAPTER 6 .....	49
MAXIMUM SOLAR ABSORPTION CAPACITY THE YEAR 2025 INTO THE SRI LANKAN TRANSMISSION NETWORK .....	49
6.1 Effect of solar ramp rate and short-term frequency stability.....	57
6.2 Short term frequency stability analysis .....	61
6.1 Study part 1: Using Combined cycle power plant.....	64
6.2 Study part 2: Using Battery Energy Storage System .....	65
CHAPTER 7 .....	71
ECONOMIC ANALYSIS.....	71
CHAPTER 8 .....	75
CONCLUSION .....	75
CHAPTER 9 .....	77
REFERENCES.....	77
Appendix A .....	80

## List of Figures

Figure 1.1: Installed Capacity and Peak Demand by year [1].....	2
Figure 2.1: Categorization of power system stability studies [22].....	5
Figure 2.2: Different uses of ESS [23].....	6
Figure 2.3: Global ESS power capacity usage in different technologies [8] .....	8
Figure 2.4: Usage of ESS due to response time and storage capacity [8].....	10
Figure 2.5: Main components of a BESS [24] .....	11
Figure 2.6: Battery cell price predictions for year 2020 [11].....	13
Figure 2.7: Distributed and Utility-scale Li-ion CAPEX predictions for year 2030 .	13
Figure 2.8: Main components and operating principal of Li-ion battery [11] .....	14
Figure 2.9: Cost breakdown of LCOE [12].....	15
Figure 3.1: Transmission model validation process [13].....	19
Figure 3.2: BEN recording of the tripping of Puttalam Coal Unit 03.....	21
Figure 3.3: Steady state model and system open points of Transmission system PSS/E .....	22
Figure 3.4: System frequency variation pre and post fault .....	23
Figure 3.5: Output power variation of Victoria Unit 01 .....	24
Figure 3.6: Simulation vs Actual frequency of pre and post tripping of Puttalam Coal Unit 03.....	24
Figure 4.1: IV characteristics of solar array [16] .....	27
Figure 4.2: Main components of a solar panel connection [17].....	27
Figure 4.3: Arrangement of a 10 MW solar plant.....	29
Figure 4.4: Single-machine equivalent representation solar plant.....	30
Figure 4.5: Dynamic model for renewable energy power plant [18].....	32
Figure 4.6: Spread of Saga solar park .....	34
Figure 4.7: Transmission line from the solar plant to Hambantota GSS .....	35
Figure 4.8: Single circuit arrangement of the power plant connection .....	35
Figure 4.9: Electrical drawing of Saga solar plant.....	36
Figure 4.10: Active power output of solar plant before tuning.....	37
Figure 4.11: Reactive power output of solar plant before tuning .....	37
Figure 4.12: Active power output variation with gain value changes.....	38



Figure 4.13: Reactive power output variation with gain value changes .....	39
Figure 4.14: Comparison of Simulation vs Actual active power output.....	39
Figure 4.15: Comparison of Simulation vs Actual reactive power output.....	40
Figure 5.1: Cloud cover variation over Sri Lanka on three different days .....	41
Figure 5.2: Solar output power variation on a normal day .....	42
Figure 5.3: Solar output power variation on a cloudy day.....	42
Figure 5.4: BESS sizing methodology .....	44
Figure 5.5: 1-second and 1-minute power output of 10 MW solar plant for a single day .....	45
Figure 5.6: Solar power output variation throughout the day on 12 <sup>th</sup> February.....	45
Figure 5.7: Solar power output variation throughout the day on 25 <sup>th</sup> April, 03 <sup>rd</sup> August and 16 <sup>th</sup> December .....	46
Figure 5.8: Battery capacity requirement variation.....	47
Figure 5.9: Battery capacity requirement variation throughout the year .....	47
Figure 6.1: Power variation of 10 MW solar power plant on a single day .....	57
Figure 6.2: Ramp rate variation of the same day .....	58
Figure 6.3: Proposed sites for solar development [25] .....	60
Figure 6.4: Total ramp rate variation applied to all the solar plants in year 2025 .....	61
Figure 6.5: Total solar power variation.....	62
Figure 6.6: Frequency variation with LNG machines as spinning reservoirs.....	65
Figure 6.7: System frequency variation with different sizes of BESS.....	66
Figure 6.8: Frequency variation with 100 MW and 150 MW of BESS.....	67
Figure 6.9: Power output of BESS .....	67
Figure 6.10: Location and surrounding of Kolonnawa 132 kV GSS.....	68
Figure 6.11: Location and surrounding of Hambantota 132 kV GSS.....	69
Figure 6.12: Location and surrounding of Kappalturei 220 kV GSS .....	70
Figure 7.1: Unit price of electricity.....	72

## List of Tables

Table 1.1: Total solar absorption capacity with different generators [3].....	3
Table 2.1: Parameter comparison of different ESS [9] .....	9
Table 2.2: Different types of Batteries [8] .....	11
Table 2.3: Advantages and disadvantages of different Battery technologies .....	12
Table 4.1: Data required to model a single-machine equivalent solar plant [17] .....	31
Table 4.2: Division of control gains among electrical controller and plant controller .....	33
Table 4.3: Control gain categorization according to the operation mode of the plant.....	33
Table 6.1: Base case generation plan for the year 2018 - 2037 [1].....	50
Table 6.2: Major power plant additions according to LCLTGEP.....	51
Table 6.3: Energy mix in year 2025 .....	52
Table 6.4: Solar power plants in year 2025.....	53
Table 6.5: Rooftop solar distribution in year 2025 .....	54
Table 6.6: required land area and time taken by a cloud to pass with the capacity of solar plant.....	59
Table 6.7: Power plant dispatch for Max NCRE case in year 2025 .....	63
Table 6.8: Minimum frequency reaches for different scenarios .....	64
Table 7.1: Data of Li-ion BESS .....	71
Table 7.2: Parameters for 150MW of BESS.....	72
Table 7.3: Data of single LNG plant.....	73
Table 7.4: Parameters of two LNG plants.....	73
Table 7.5: LCOE calculation for CCY and bess .....	74

### **1.1 Present Sri Lankan Power System**

Sri Lanka is an island in the Indian ocean with a population of 21 million and an area of 65,000 km<sup>2</sup>. The country is 100% electrified and has an islanded grid network, which provides 24 hours continuous power supply throughout the year. Currently, Sri Lankan power system consists of hydro, thermal, biomass, wind and solar PV power plants connected to the transmission system, which operates at 132 kV and 220 kV voltage levels.

The total installed capacity of all hydro power stations owned and operated by Ceylon Electricity Board (CEB) as at 31<sup>st</sup> December 2018 is 1,399 MW. The total installed capacity of all thermal power plants owned and operated by CEB is 1,504 MW. In addition, 560 MW of private thermal power plants are connected to the system. As at 31<sup>st</sup> December 2018, approximately 585 MW of other renewable energy (ORE) plants are connected to the national grid, which consists of 368 MW of mini hydropower plants, 128 MW of wind power plants, 37 MW of wood fuel/dendro power plants and 51.6 MW Solar power plants. The peak power demand of the country in the year 2018 was 2,616 MW while total installed capacity of the system was 4,048 MW at the end of 2018. The demand for electricity has been increasing at a rate of 6.5% per annum during the last 25 years as shown in Figure 1.1 [1]. However, it is noted that the growth in peak demand during the period 2011-2014 is almost zero, while there is about 6.5% growth in peak demand during last three years.

### **1.2 Problem Statement**

According to the government policies, it has been planned to integrate at least 20% of non-conventional renewable energy (NCRE) by year 2020. Since solar is an intermittent power source, its output power varies drastically with the cloud cover. This phenomenon results in power system stability issues. With varying power generation, system frequency tends to vary risking the stability of the power system.

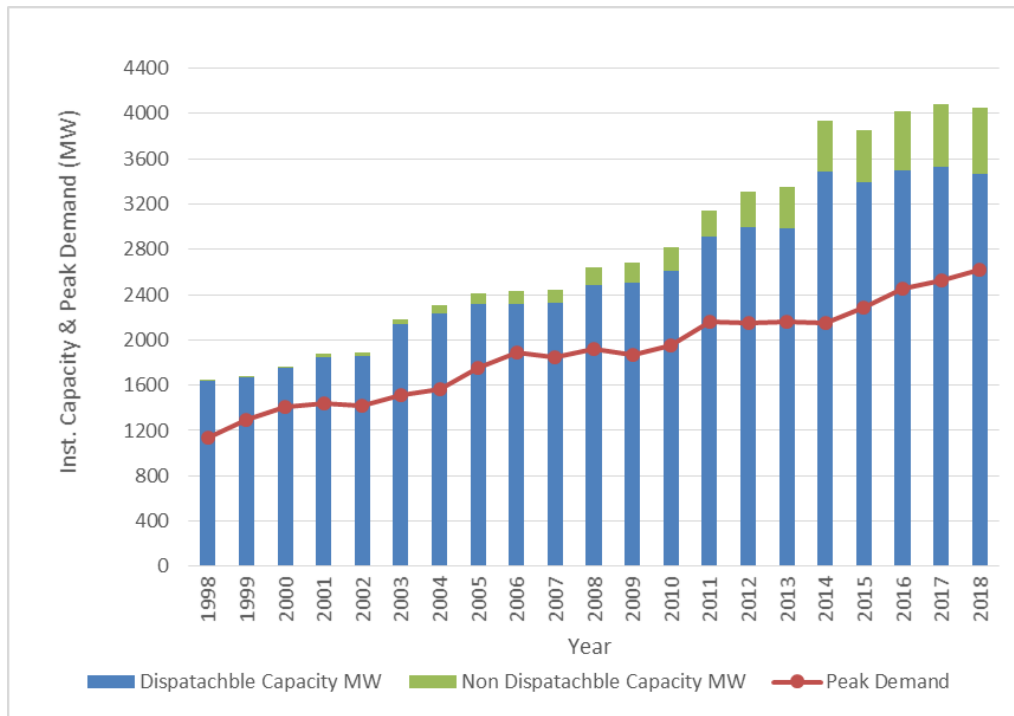

Figure 1.1: Installed Capacity and Peak Demand by year [1]

According to the standards specified in the draft grid code, [2] to maintain system frequency stability, frequency should be within the limit of  $\pm 1\%$  of 50 Hz (i.e. 49.5 - 50.5 Hz). This limits the integration of renewable power generation into the power system. According to the, ‘Integration of renewable based generation into Sri Lankan Grid 2017-2028’ prepared by the Transmission and Generation Planning Branch [3], Ceylon Electricity Board, by year 2020, the total absorption capability of solar power into the network is 582 MW. The total solar absorption capacity in year 2018 and 2020 with different generators keeping as spinning reservoirs is shown below in Table 1.1 [3].

Table 1.1: Total solar absorption capacity with different generators [3]

Year	Scenario	Solar absorption capacity
2018	Victoria only	117 MW
	Victoria + GT7	180 MW
	Victoria + KCCP	210 MW
	Victoria + Kotmale + Upper Kotmale + New Laxapana	290 MW
	Victoria + KCCP + GT7 + 2x35MW GTs	300 MW
2020	Victoria + Kotmale + Upper Kotmale + New Laxapana	302 MW
	Victoria + KCCP + GT7	272 MW
	Victoria + KCCP + GT7 + LNG	522 MW
	Victoria + KCCP + GT7 + LNG+ 2x35MW GTs	582 MW

In the least cost long term generation expansion plan 2018 – 2037 of Ceylon Electricity Board [4], it has been proposed to integrate 1,000 MW of solar capacity into the Sri Lankan network by year 2025. Among this, 300 MW will be connected as rooftop solar plants to the low voltage network and the remaining 700 MW will be connected to the medium and high voltage network as 1 MW-10 MW plants or solar parks.

In a wet period (high hydro scenario), when all 1000 MW of solar is generating, in order to maintain the system stability, at least two combined cycle plants operating with liquefied natural gas (300 MW each) will have to operate violating the merit order and may be spilling large reservoirs. This is not economical. Therefore, grid connected solar absorption capacity has been limited to 423 MW out of 700 MW.

### 1.3 Research Objectives and goal

The goal of this project is to increase the power system’s capability to add more solar power by year 2025.

The specific objective is:

To conduct a techno-economic analysis on using battery energy storage system for smoothing the effect of solar intermittency and improve solar absorption capacity in Sri Lankan power system by year 2025.

## **1.4 Thesis Overview**

The objective of this research is to carry out a technical as well as economical study on utilizing battery energy storage systems to reduce the effect from solar intermittency and introduce more solar power into the Sri Lankan power grid. The study has been carried out using the software Power System Simulation for Engineers (PSS/E) developed by Siemens PTI. Therefore, as a first step, the existing PSS/E model Sri Lankan transmission network has been validated. Model simulation output has been compared with the actual fault output during a critical fault (single unit tripping of Puttalam Coal power plant).

Since the study is about solar plants, model validation for an existing 10 MW plant has been carried out. 1-second power output data has been collected from Hambantota 10MW solar plant for six weeks by using Fluke meters and 1-minute data of solar output has been collected for one-year period from the Sustainable Energy Authority. With these data, the size of a BESS required to smoothen out power output of a 10 MW solar plant has been calculated using python script. Thereafter load flow studies, stability analysis, contingency and dynamic studies of the Sri Lankan power system have been carried out in order to calculate the solar absorption capacity in year 2025 using PSS/E software. Finally, an economic analysis has been done with compared to using combined cycle power plants.

2.1 Power System Stability

Power system stability analysis is carried out to study a power system’s ability to withstand large disturbances, such as loss of generators or transmission lines, faults etc. A stability study could analyze the transient frequency stability, voltage stability and synchronous generator rotor angle stability. These studies could be categorized according to the physical nature or main system parameter, size of disturbance and time span as shown below in Figure 2.1.

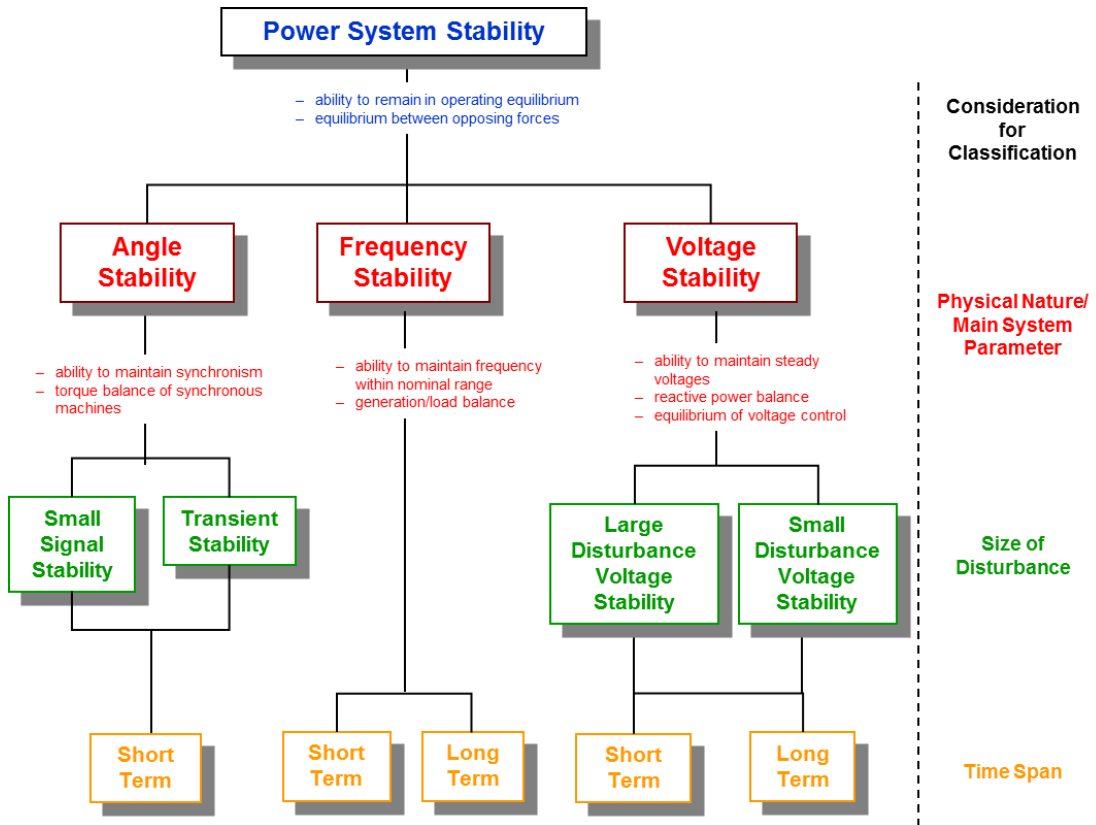

Figure 2.1: Categorization of power system stability studies [22]

When integrating high capacity of intermittent power sources in to the power system, the system inertia reduces and as a result, stability studies plays a major role in variable renewable generation integration process.

Integrating large scale solar parks has a high impact on system stability, since solar plants do not have inherent inertia, and the output power of the solar plant varies according to the cloud cover [5] This variation could exist in the range of few seconds to few minutes depending on the size of the plant. Therefore, short term small signal stability studies are required to identify and limit the penetration level of solar capacity into the power system. Energy storage systems are widely researched and proposed as a solution for the stability issues due intermittent nature of renewable sources [6].

## 2.2 Energy Storage Systems (ESS)

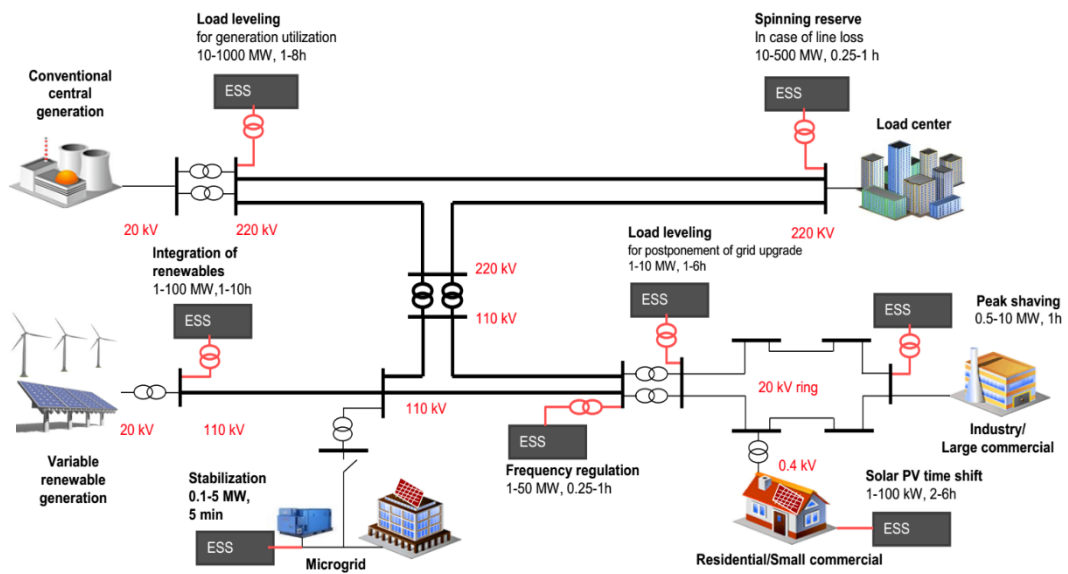

Figure 2.2: Different uses of ESS [23]

Energy Storage Systems (ESSs) can be used to store electrical energy received from the power grid to match the difference between power supply and demand. Energy storage is capable of benefiting all parts of the system – generation, transmission and distribution – as well as customers.

Services provided by an ESS can be categorized as follows [7]

Bulk energy services:

- Electric energy time shift (arbitrage)
- Electric supply capacity



- Avoided renewable curtailment

#### Transmission infrastructure services

- Transmission upgrade deferral
- Transmission congestion relief

#### Distribution infrastructure services

- Distribution upgrade deferral
- Voltage support
- Outage mitigation

#### Ancillary services

- Regulation
- Spinning, Non-spinning and Supplemental Reserves
- Voltage support
- Black start

#### Customer energy management services

- Power quality
- Power reliability
- Retail electric energy time shift
- Demand charge management

#### Off grid

- Solar home systems
- Mini grids – system stability services

#### Transport sector

- Electric two or three wheelers, buses, cars and commercial vehicles

Based on the technology used, these ESS could be mainly categorized into pump hydro storage, electro-chemical, electro-mechanical and thermal storage [8] Global energy storage power capacity usage for the above-mentioned purposes based on their technology is shown below in Figure 2.3.

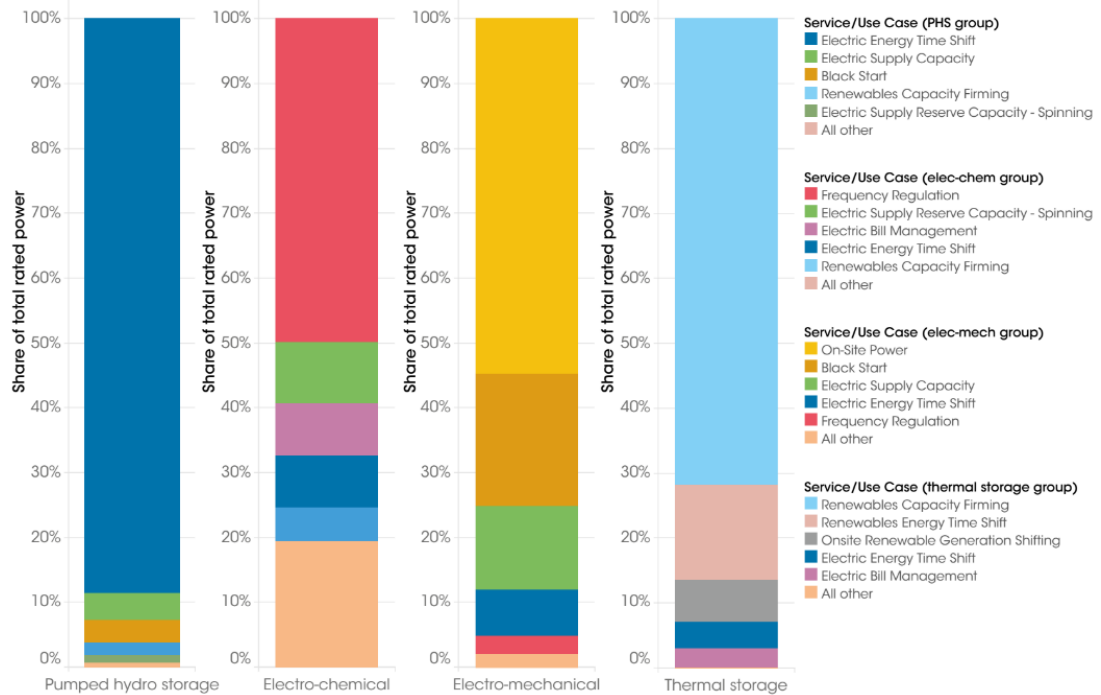

Figure 2.3: Global ESS power capacity usage in different technologies [8]

It could be clearly seen that pumped hydro storage has been implemented for the purpose of electric energy time shift, which shifts the electricity supply from times of low demand to times of high demand to reduce generation costs and this is the most mature technology at present. Electro-chemical storages (mainly batteries) are used globally for frequency regulation due its high response time. Thermal storages are widely used for renewable firming (mainly in solar PV plants).

These technologies are further categorized as

- Chemical energy - in batteries
- Rotational kinetic energy - in flywheels
- Pressure potential energy - in compressed air storage systems
- Gravitational potential energy - in pumped hydro-electric facilities

- Electrical charges - in capacitors
- Magnetic fields - in super-conducting magnetic energy storage

The ESSs differ from each other with regard to their response time, discharge duration, efficiency and life time. A parameter comparison of ESSs is given below in Table 2.1 [9].

Table 2.1: Parameter comparison of different ESS [9]

Technology	Power (MW)	Energy (MWh)	Efficiency (%)	Life cycle (x1000)	Response Time	Discharge Duration
Pumped Hydro	280-1400	1700-14000	70-80	13	10 min	Hours
CAES	50-180	1400-3600	50	10-13	10 min	Hours
Flywheel	0.01-100	0.005-200	80-95	100	10 min	Minutes
Batteries	0.01-100	0.001-200	60-80	2-5	Seconds	Hours
SMES	0.2-100	0.0001-0.2	95	40 yrs	Milli seconds	Seconds
Capacitors	0.1-1	0.000001-0.001	95	40 yrs	Milli seconds	seconds

CAES - Compressed air energy storage systems

SMES - Super-conducting magnetic energy storage systems

The following Figure 2.4 shows usage of ESSs regarding to their capacity and response time [8]. Pump hydro and CAES have the capability to discharge for up to ten hours, therefore they are used for bulk power management. Conversely, flywheels are used for uninterruptable power supply applications or to improve power quality as they have lesser response times. For grid support, load shifting and renewable smoothing flow batteries, NaS batteries, advanced lead acid batteries, NaNiCl batteries, lead acid batteries are used.

This shows that the battery energy storage systems have the capability of renewable smoothing with their shorter discharge times and higher power capacities.

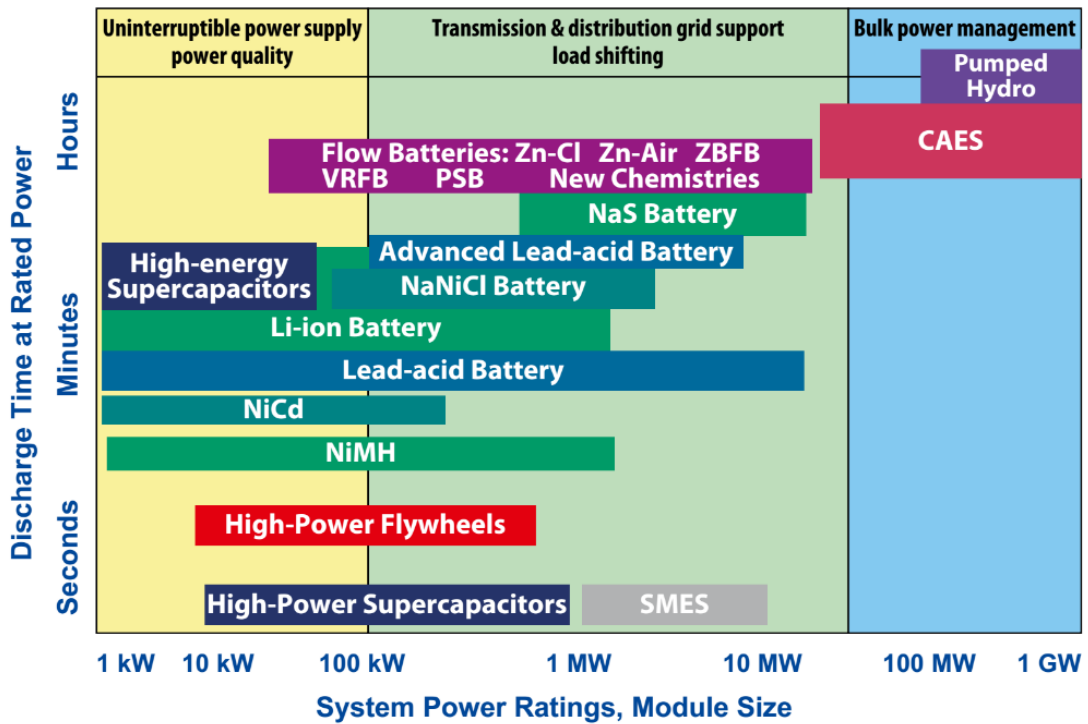

Figure 2.4: Usage of ESS due to response time and storage capacity [8]

### 2.3 Battery Energy Storage Systems

When the penetration level of intermittent power sources increases, the output power tends to fluctuate increasing the risk of reliability supply of the power grid. Energy storage provides the capability to reliably integrate electricity produced from intermittent power plant. Since the output power of renewable power plants have a high variation (due to cloud cover in solar PV, varying high wind speeds, etc.), it is required to use an ESS, which has a very high response time. Therefore, Battery Energy Storage Systems (BESS) becomes the most optimal solution for frequency regulation and renewable power output smoothing [10].

A BESS comprised of a battery storage, power conversion system and a battery management system. The following Figure 2.5 shows this configuration.

Battery storage is used to store energy and the Power conversion system handles the conversion of energy from the battery to the grid, and the other way around. The Battery management system monitors and controls the battery and overall system.

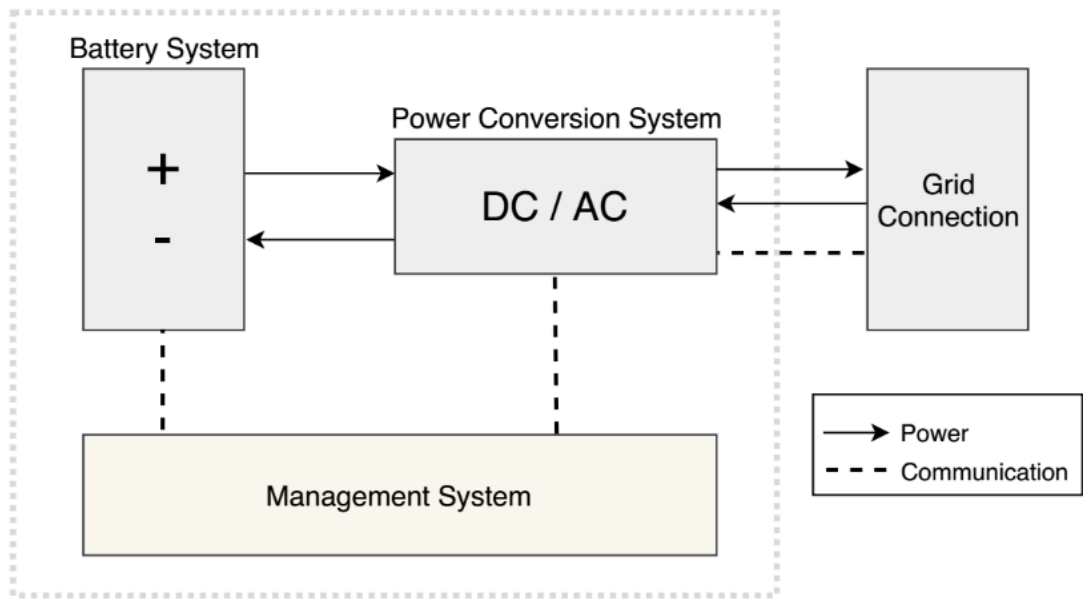

Figure 2.5: Main components of a BESS [24]

Although BESS is an emerging market, battery is not new in technology. They store electrical energy in a chemical format. According to the dissimilarity of their build and use of chemical components, several types of batteries exist and they could be categorized as follows [8].

Table 2.2: Different types of Batteries [8]

Low temperature batteries	High temperature batteries	Redox flow batteries
Lithium-ion	Sodium nickel chloride	Vanadium
Lead-acid	Sodium-sulphur	Zinc bromine
Nickel cadmium		

Among these battery types lead-acid, lithium-ion, sodium-sulphur and vanadium redox flow batteries are widely used for BESS applications [8].

Lead-acid is the most matured technology as well as the cheapest. Vanadium redox flow batteries are very high in cost although it's all other performances are greater than almost all other batteries. Sodium Sulphur battery faces a practical issue due its higher

operating temperature around 300-350°C increasing the risk of fire. Main advantages and disadvantages of the above four battery technologies are depicted in the following Table 2.3 [8].

Table 2.3: Advantages and disadvantages of different Battery technologies

Type	Advantages	Disadvantages
<b>Lead – acid battery</b>	Reliable	High risk of environmental pollution
	Low cost	Low efficiency
	Mature	High self-discharge
	Long operation life	Limited depth of discharge
<b>Vanadium redox flow battery</b>	High capacity	High cost
	No limit to depth of discharge	Shortage of material
	Long lifetime	Low energy density
	Low risk of pollution	Underdeveloped technology
<b>Sodium-Sulphur battery</b>	Abundance of materials	High operating temperature
	Cheap	Safety risks
	High energy density	Corrosion
	High efficiency	
<b>Lithium-ion battery</b>	Commercialized	High cost
	High efficiency	Limited supply of materials
	High capacity	Safety risks
		Limited life time

As shown in the above table Lithium-ion is superior over other technologies in terms of efficiency, energy and power capacity and density. It has been predicted that lithium-ion batteries will reach the lowest cell price and capital expenditure in the near future. This is depicted in the Figure 2.6 [11]. Therefore, Lithium-ion batteries are widely used for utility scale BESS applications.

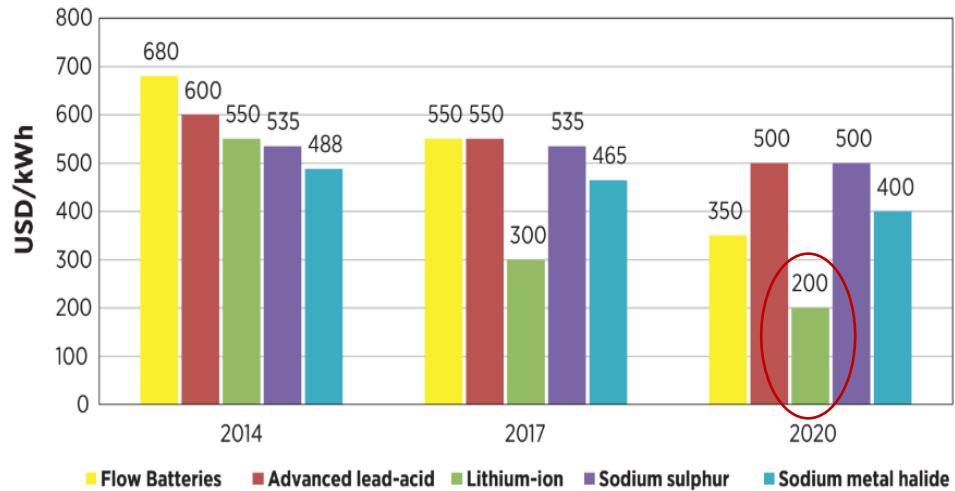

Figure 2.6: Battery cell price predictions for year 2020 [11]

### Lithium – ion Batteries

Lithium-ion battery is comprised of a graphite anode, a lithium metal oxide (LiMEO<sub>2</sub>) cathode based on cobalt, and an electrolyte of organic liquid with lithium salt. It exchanges lithium ions (Li<sup>+</sup>) between anode and cathode. The Figure 2.87 shows the main components and operating principle of a lithium metal oxide cathode and carbon-based anode [8].

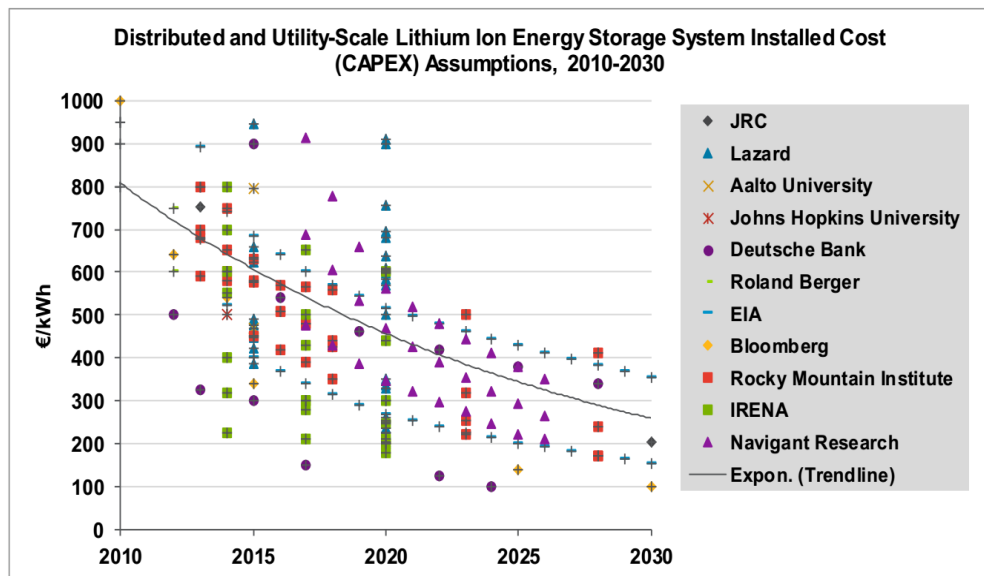

Figure 2.7: Distributed and Utility-scale Li-ion CAPEX predictions for year 2030

When compared with others, Li-ion batteries have a high specific energy, high power density and high energy level. Their round-trip efficiency is high, which provides a long lifetime. Li-ion battery has a high rate with high power discharge ability as well as low self-discharge rate. The disadvantage is there's a safety issue with the chemical reaction of the operation of the battery which results overheating of the cathode increasing thermal instability and risk of fire. There are actions taken and researches ongoing to monitor and manage this safety issue [11].

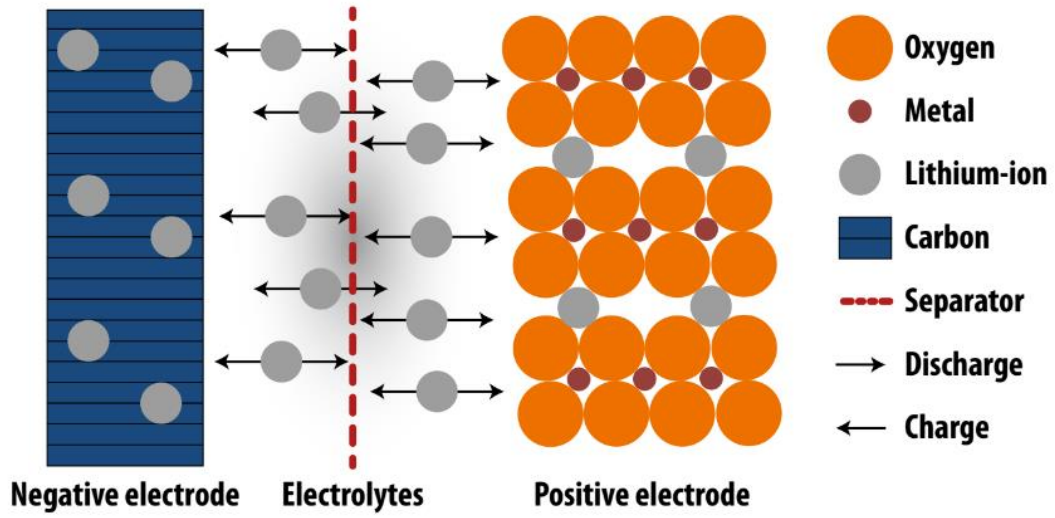

Figure 2.8: Main components and operating principal of Li-ion battery [11]

#### 2.4 Levelized Cost of Energy (LCOE) and Levelized Cost of Energy Storage (LCOES)

Levelized Cost of Energy (LCOE) is a method of calculating financial cost of electricity generation. The LCOE is defined as the net present value of the unit cost energy over the lifetime of a generating asset and elaborated in the Figure 2.9. This could be used to compare cost between two different generating technologies [12].

The LCOE method is described by the equation (2.1).

$$LCOE = \frac{\sum_{i=1}^n \frac{I_i + OM_i + F_i}{(1+r)^i}}{\sum_{i=1}^n E_i} \quad (2.1)$$



Where,

- $I_i$  = Investment expenditures in year  $i$
- $OM_i$  = Operation and maintenance expenditures in year  $i$
- $F_i$  = Fuel expenditures in year  $i$
- $E_i$  = Energy generated in year  $i$
- $r$  = Discount rate
- $n$  = Lifespan or comparison time

Levelized cost of energy storage (LCOES) is a method to calculate the cost of energy storage. Here, instead of fuel cost, charging cost is added divided by the round-trip efficiency [12].

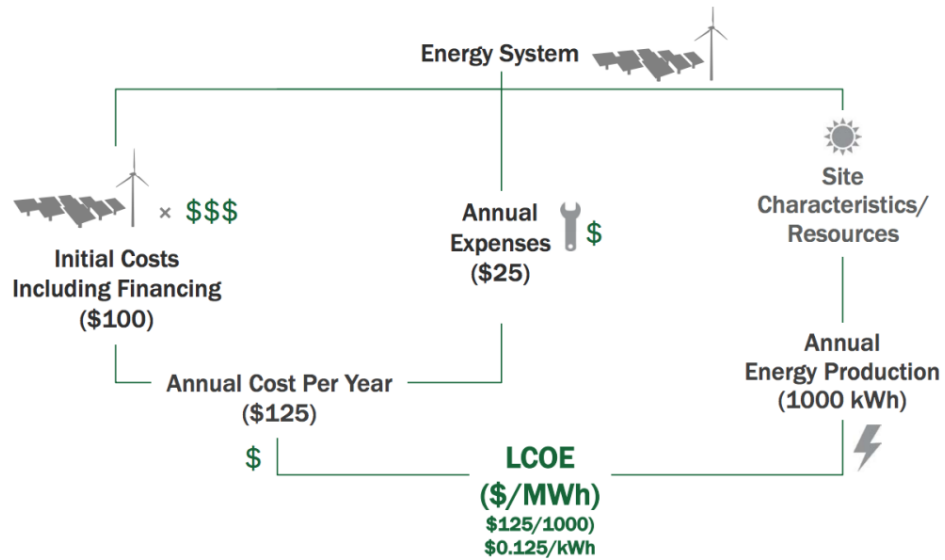

Figure 2.9: Cost breakdown of LCOE [12]

$$LCOES = \frac{\sum_{i=1}^n \frac{I_i + OM_i}{(1+r)^i}}{\sum_{i=1}^n E_i} + \sum_{i=1}^n \frac{P_{in_i}}{E_i \eta (1+r)^i} \quad (2.2)$$

Where,

- $P_{in}$  = Charging electricity tariff
- $\eta$  = Round trip efficiency

### TRANSMISSION MODEL VALIDATION

---

A power system can be represented with a set of mathematical models in order to carry out the power flow calculations in power system planning, designing and operating. Due to the vast amount of equipment in a power system, it is required to get an assistance of a load flow simulation software like PSS/E, PSLF, DigSILENT, ETAP etc. Computer simulation models of power systems provide an effective and reliable means of planning, designing and operating of the bulk power system.

A reliable system model is a mandatory requirement of the system's utility. Some of the important aspects of power system modeling are [13];

- Provides the ability to predict system behavior and interaction of generators, transformers, reactive power compensators etc.
- Enhance system security by improving the view of the system
- Heighten situational awareness
- Increases the effectiveness of generation dispatch and transmission asset utilization
- Provides flexibility to reliable integration of generation plants, grid substations, reactive compensators and loads into the system as technology and characteristics develop.

The basis of a power system study is to model the existing system and to validate it. Validation of the overall power system in a computer aided software will result in more precise representation of actual system events. An accurate model representation of a power system will lead to optimal and economic planning while the system operates in a more secure state.

Steady state models (or power flow cases - a collection of steady state models for system topology, load, and dispatch that constitute a snapshot of expected system performance for the selected set of operating conditions) are the foundation of a system studies. Hence, they are required to validate periodically with actual system measured

values and operational practices in order to keep the simulation operating closer the actual system conditions.

Validation of a power system is carried out by recreating the power flow case to match a system condition of a specific moment in time in the past such as tripping of a large generator unit, tripping of a critical transmission Line, bus bar fault, load rejection etc. Generation dispatch, load profiles, reactive power compensators, network configuration, plant dynamics and operational characteristics of the case are adjusted to match the conditions that actually existed at that time. Then the power flow case needs to be solved using an iterative method (ex. Newton Raphson, Gauss Seidal) and then compare if the results of the simulation match the actual output.

The currently existing network can be validated directly. Transmission line data can be based on line parameter calculations (R, X, B) and transformer data could be extracted from the actual manufacturer nameplate. FACTS and HVDC models are often develop with the help of the manufacturer. Generator testing is required to validate the power plant models. The main approach presently in generator testing is to perform staged tests. That is, planned maneuvering of the unit that often includes rejecting small amounts of real and reactive power to record the unit's dynamic behavior and hence extract parameters for computer simulation models of the generator, excitation system and turbine-governor controls. Online disturbance monitoring or ambient monitoring is the current approach of power plant model validation.

After the power flow model is assembled, it should be tested for any data errors before using it. Errors of data in the power flow may cause solving issues of the steady state case as well as initialization errors in the dynamics data. Data inconsistencies of a case could be;

- Applied maximum limit is less than minimum limit
- Applied values outside of specified limits
- Transformer voltage control range smaller than transformer tap step (results in endless hunting in power flow solution)
- Conflicting voltage set points from multiple regulating devices

Therefore, it is essential to carry out a data check and resolve any existing issues.

The model validation process starts with modeling the steady state load flow case (transmission lines, transformers, shunt devices, generators, and loads). Next, a particular system disturbance is selected. In order to compare the simulation results vs, the actual event record, it is essential to construct the system as it is prior to the disturbance. Therefore, certain data regarding the disturbance is required for validating a system dynamics case, including

- Type of the event or events
- Sequence of the events
- Location of the event etc.

Figure 3.1 below illustrates the sequence of a power system model validation process.

Then the results of the solved power flow case are compared against the data recorded from the actual disturbance. Parameters which can be compared are [14];

- Real power output of system slack and area slack machines
- Generator reactive power output and voltage
- Real and reactive power flows of lines and transformers
- Interface flows – real and reactive
- ULTC transformer tap position and voltage
- Phase-shifting transformer angle position and MW and Mvar flows
- Bus voltages
- Bus voltage angles (where available)
- Static VAR devices reactive output and voltage
- DC lines terminal voltage, MW flows, and reactive power consumption

It is unrealistic to expect the simulation results match to the observed system conditions exactly. However, it is desired to replicate the voltages and flows to the greatest extent possible. As a starting point, modeled flows should be targeted to be within  $\pm 10\%$  of measured, and modeled voltages should be within  $\pm 3\%$  of measured. This range will allow for limitations of system SCADA measurements and potentials for errors in measurements.

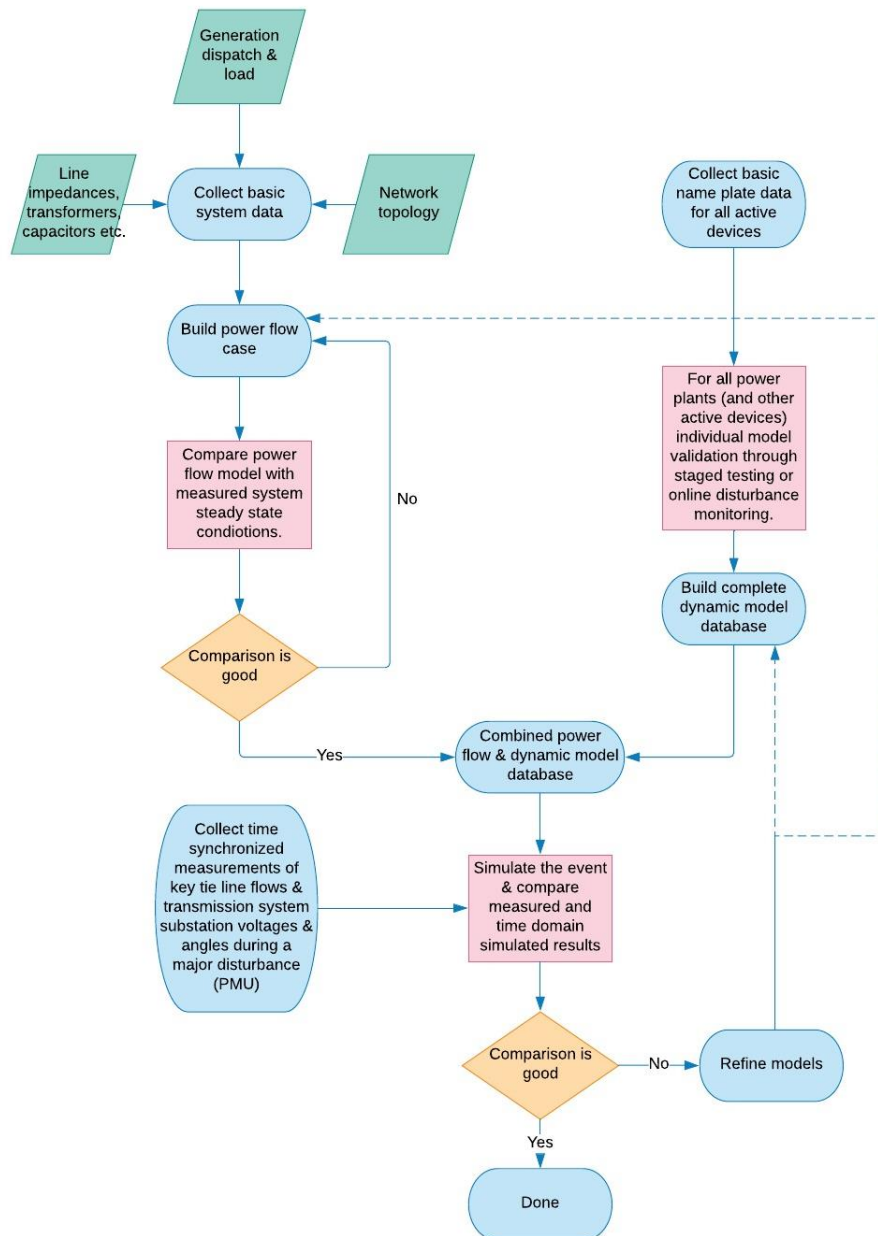

Figure 3.1: Transmission model validation process [13]

### 3.1 Power System dynamic modeling in PSS/E

There is a wide range of dynamic models available in PSS/E model library to be chosen for power system analysis. PSS/E Dynamic models can be broadly classified into the following categories:

- Device models - these are attached to specific equipment in PSS/E power flow (e.g. models of generators, loads etc.). For any given equipment, there can be only one device model attached to it
- Protection models
- Miscellaneous model of type “other” - these are unattached models in the sense that these may or may not be attached to any specific equipment in PSS/E power flow

The PSS/E Model Library contains a wide variety of equipment models which satisfy this requirement for a vast majority of generating plant equipment. However, situations may arise in which there is no library model which corresponds to the differential equations needed to model a given piece of equipment. To handle this situation, engineers historically have tried to modify the data characterizing the equipment to fit the block diagram of an existing model. Rather than resorting to this approach, the PSS/E user is encouraged to write a model that accurately models the equipment.

For the model validation discussed, following PSS/E dynamics models were used and listed below [15].

- Conventional Generator – GENROU, GENSAL
- Governor – HYGOV, GAST, TGOV1
- Exciter – SEXS, EXST1

Model SEXS is particularly useful in cases where an excitation system must be represented and its detailed design is not known

- Load – CLODAL

This model represents a composite load of induction motors, lighting, and other types of equipment fed from many typical substations. It is intended for use in situations where it is desirable to represent loads at the dynamic level, as distinct from the algebraic characteristic level used in power flow, but where detailed dynamics data is not available

- Generic Wind Models – WT4G1, WT4E1, WT3G, WT3E
- Generic Solar Models

### 3.2 Sri Lankan power system validation

Event details considered for Sri Lankan power system model validation are as below.

Disturbance	:	Tripping of Puttalam coal unit 03
Dispatch prior to event	:	197 MW
Date	:	07.11.2017
Time	:	01:54 am

Actual system data records of the event were collected from the fault event recorder (BEN recorder) installed in the Puttalam coal 220 kV grid substation. This data includes system frequency, current and voltage data of the lines going out from the Puttalam coal 220 kV grid substation (i.e. Puttalam Coal – New Chilaw 220 kV transmission line and Puttalam Coal – New Anuradhapura 220 kV transmission line). Frequency plot of the moment where the disturbance occurred is shown below in Figure 3.2.

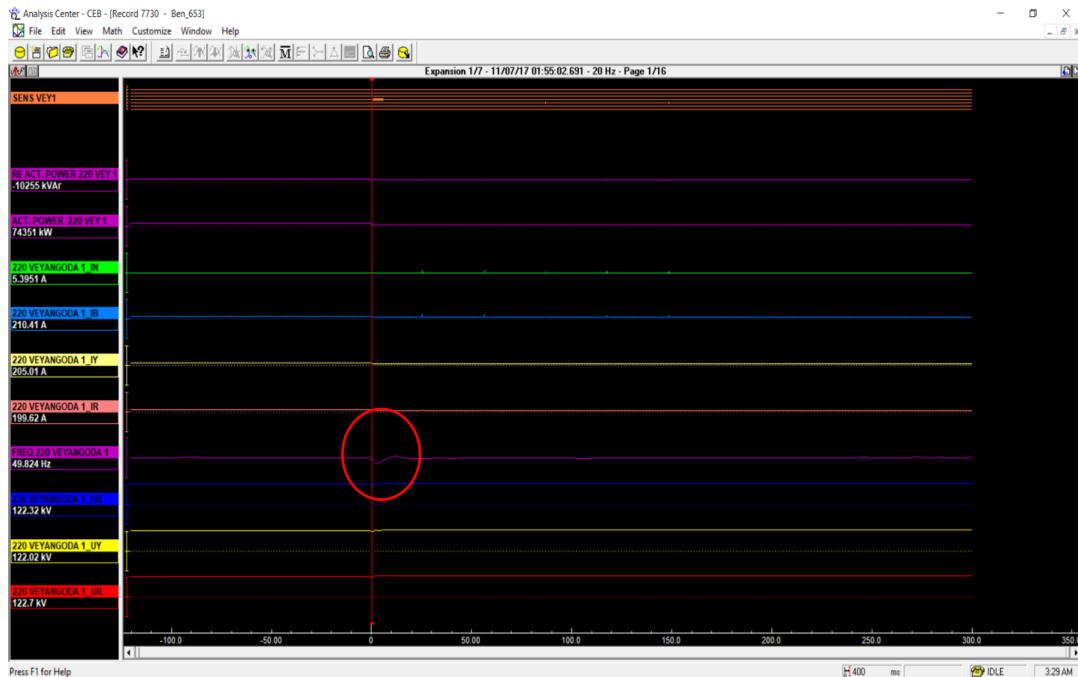

Figure 3.2: BEN recording of the tripping of Puttalam Coal Unit 03

Unit 03 of Puttalam Coal Plant tripped and system recovered with Under Frequency Load Shedding.

The system data prior to the event were collected from the National System Control Centre and the system before the disturbance is recreated using the PSS/E software. This data includes generation dispatch, loading of grid substations and state of the capacitor banks as at 01:30 am on the same day. These data are given in Appendix A.

The scenario recreated in the PSS/E software is shown below in Figure 3.3. Transmission lines which were at open position due to system instability issues and planned outages at the time are highlighted and detailed below.

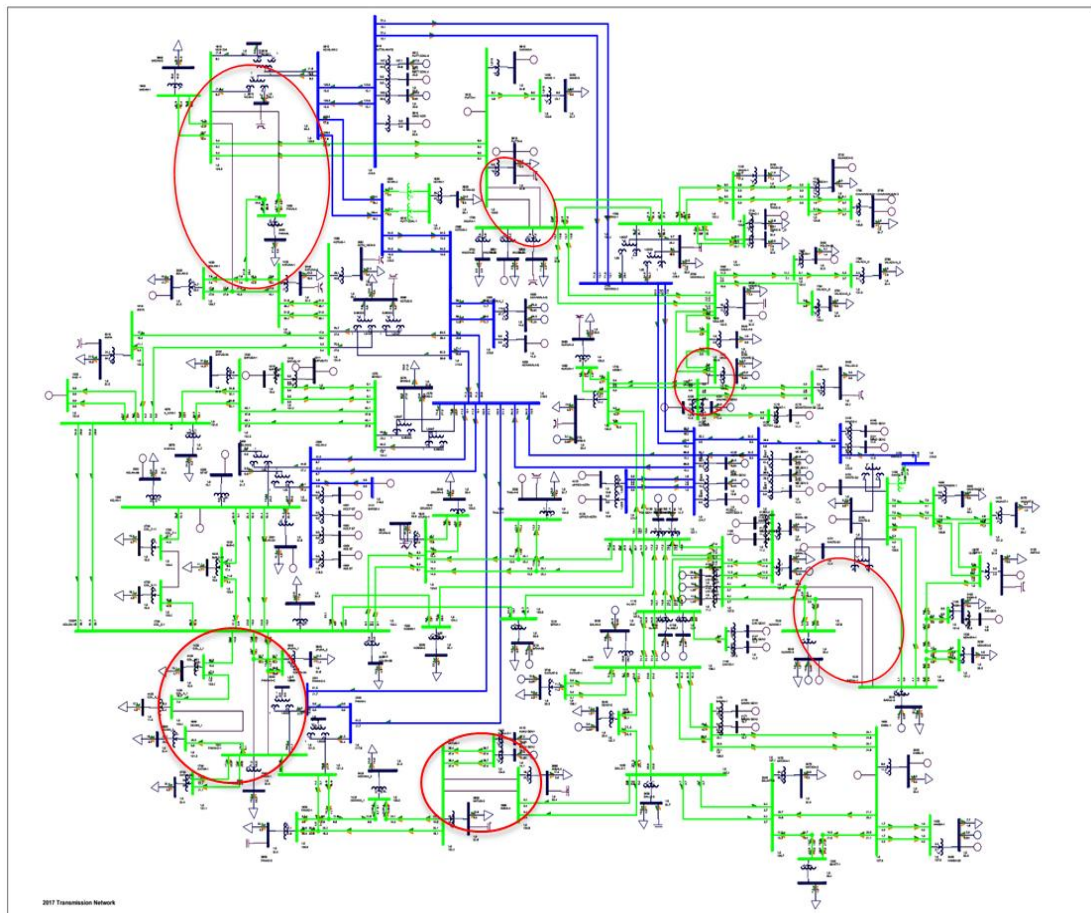

Figure 3.3: Steady state model and system open points of Transmission system PSS/E



System open points when the fault occur was;

- Galle – Ambalangoda 132 kV transmission line off
- Badulla – Nuwara eliya T point 132 kV transmission line off from Badulla end
- Old Anuradhapura – Puttalam 132 kV transmission line off
- New Chilaw – Pannala and New Chilaw Bolawatta 132 kV transmission lines off
- Sri Jayawardhanapura T point – Pannipitiya 132 kV transmission line off
- Havelock Town – Dehiwala 132 kV underground cable off
- Kollupitiya – Fort 132 kV underground cable off
- Ukuwela 132 kV double bus bar coupler is open and splits the network
- Pannipitiya 220 kV and 132 kV buses are split

Steady state and dynamic studies for the above-mentioned scenario was carried out. The disturbance (tripping of single unit at Puttalam Coal Power Plant) is carried out at 2s. First a three-phase fault is applied to the 220 kV bus of Coal unit 03 and after 0.12 s (i.e. 6 cycles) the fault is cleared and the plant is tripped. System frequency variation and power output variations of several power plants are shown in below Figure 3.4 and Figure 3.5.

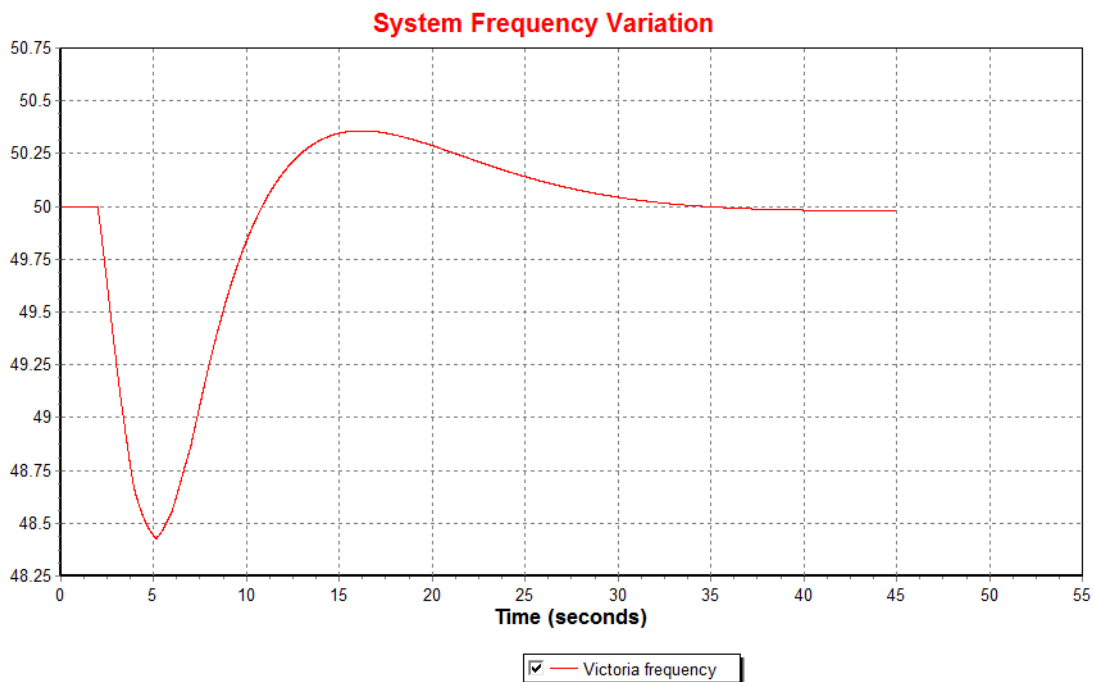

Figure 3.4: System frequency variation pre and post fault

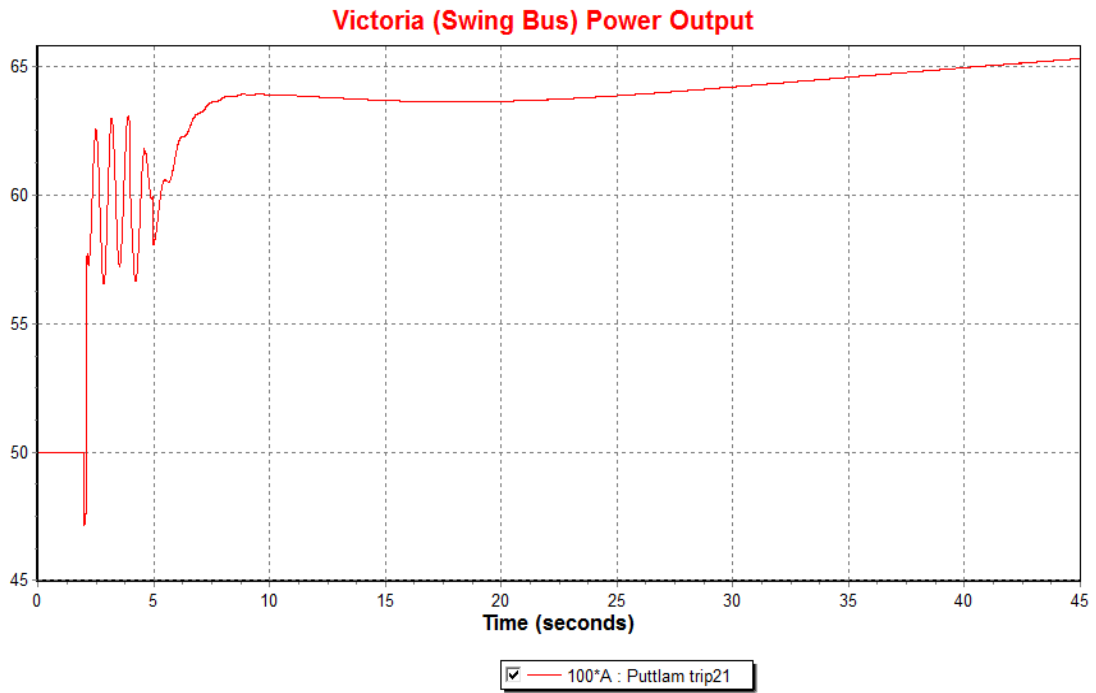

Figure 3.5: Output power variation of Victoria Unit 01

The actual system variation recorded from the BEN recorder and the simulated output from the PSS/E software has been graphed on top of each and shown in below figure 3.

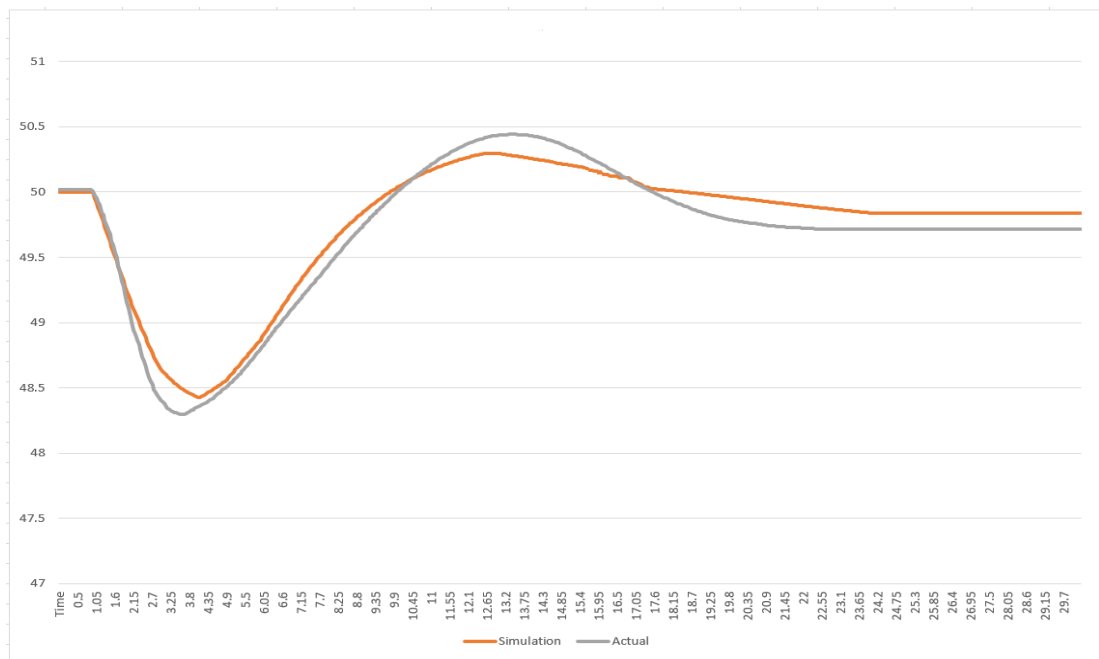

Figure 3.6: Simulation vs Actual frequency of pre and post tripping of Puttlam Coal Unit 03

As shown above, the simulated results have similar variation to the actual output data recorded at the moment. Reasons causing the minor deviations could be;

- Generation dispatch and grid loading data records are at 01:30 am which is 24 minutes before the disturbance occurred.
- Loads aren't modelled as in the actual system.
- Some of the Generator (saturation curves) and Governor Data were not available (ex: Bowatenna and Canyon generators) and typical parameters have been used.
- Renewable energy generation and operation data aren't monitored online.

The above Figure 3.6 shows that the PSS/E simulation results follows the actual scenario within a small margin of tolerance. Hence it can be concluded that the existing transmission model of the Sri Lankan power system modeled in PSS/E is validated and could be used to carry out further studies.

According to the government policies it has been planned to integrate at least 20% of Non-Conventional Renewable Energy by year 2020. When compared to wind power plants, solar power plants require less capital and could be implemented within at least 6 months. Also, the environmental impact is lesser and much easier process to follow when constructing a solar plant. Therefore, the government, Ceylon electricity board, Sustainable Energy Authority, etc. encourage the developers to develop large amount of solar generation all over the country in the form of parks or distributed solar plants.

As an initiation, two tenders of 1x60 MW and 1x90 MW solar power plants have been floated recently. These are in the form of 1 MW power plants connected to the 33 kV level to the grid substations or tapped to transmission lines. These two tenders were in the form of competitive bidding and was awarded to the bidder who was technically sound with the lowest unit price. Among the above 150 MW solar capacity, 126 MW was awarded and will be connected to the national grid in recent future.

At present five solar power plants with a capacity of 10 MW is connected to the system and among it 30 MW is connected to Hambantota Grid Substation and remaining 20 MW is connected to Vavuniya and Valachchenai Grid Substations. Other than this, 150 MW of rooftop solar capacity is already integrated to the system.

In a solar power system, the direct radiation from sun is converted into direct current (DC) electricity. The current and power output of the panel, at a given irradiance and temperature, is a function of terminal voltage. IV characteristics of solar array are shown in Figure 4.1 [16].

The voltage vs current characteristic is non-linear. The maximum power output for any irradiance level will be extracted from a certain voltage level. Other than irradiance level, ambient temperature, wind speed, etc. affects the power output from a solar array. In order to harvest the maximum power output from a solar plant, the solar arrays are mounted on sun tracking structures.

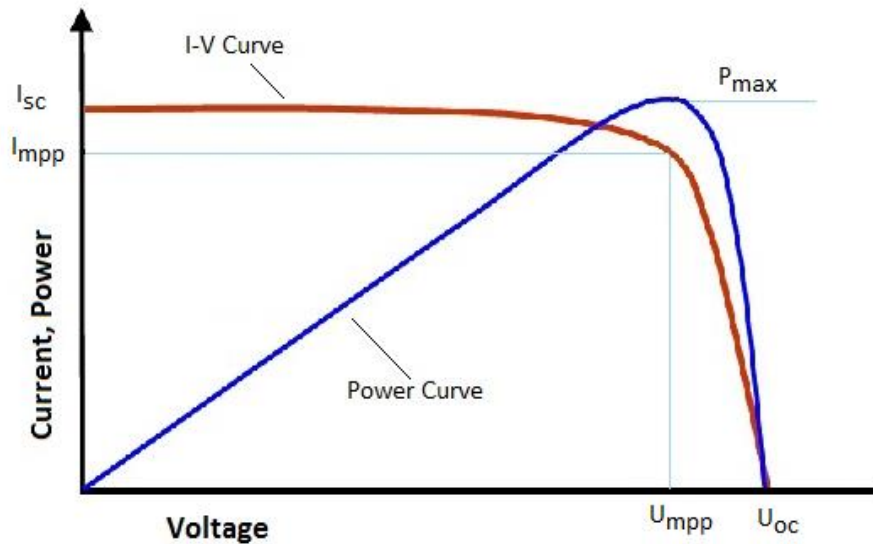

Figure 4.1: IV characteristics of solar array [16]

The DC output from the PV array is converted to AC using a three-phase inverter as shown in Figure 4.2. A PV inverter is generally made of a DC bus and three pairs of power semiconductors and it is connected to the national grid via a filter and a transformer along with control and protection equipment [17]. Nowadays most commonly used power semiconductor is insulated-gate bipolar transistors (IGBT) as it can be turned on and off very fast within microseconds (thus, the loss from power switching is low), and it has a low conduction loss.

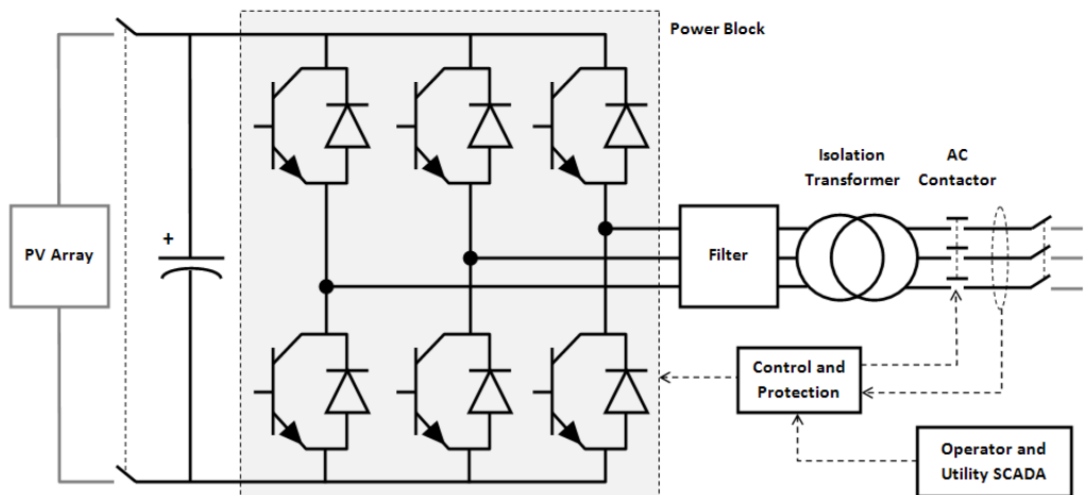

Figure 4.2: Main components of a solar panel connection [17]

The inverter's main objective is maximum power tracking, i.e. the capacitor is controlled to operate when the PV array operates at the point where it extracts the maximum power output. The inverter has the ability to regulate ac current magnitude rapidly so that current and temperature limits of the switching elements are not exceeded. Also, inverters could be used to change power and to achieve reactive power control objectives at the plant level. Harmonic injection to the grid is reduced by means of isolation transformer and filter. Furthermore, filtering could be used to reduce ripple effect of DC side and high frequency electromagnetic emission at the output. The inverter continuously monitors the grid and disconnects the inverter from the grid when the tolerance limit of frequency and voltage exceeds.

Medium scale solar plants (1 MW – 10 MW) are connected to grid substations via 33 kV transmission lines and small-scale solar plants are directly connected to the distribution network. At present the largest capacity of solar plant implemented in Sri Lanka is 10 MW. There are three numbers of 10 MW plants connected to Hambantota grid substation, one 10 MW plant to Vavuniya and another one 10 MW plant is connected to Valachchenai grid substation.

In general, a solar plant comprises of several numbers of inverters connected to a medium voltage collector system and will connect to the national grid. In Sri Lankan 10 MW solar plants, typically 2 maximum point power trackers are connected to a 1.25 MW central inverter. Two of these inverters are connected to a 2.5 MVA inverter transformer which will step up 400 V into 33 kV. There are 8 inverters and 4 inverter transformers for a typical 10 MW solar plant. All the four transformers are connected to a common 33 kV bus and will connect to the nearest grid substation or transmission line via a single or double circuit 33 kV lynx transmission line.

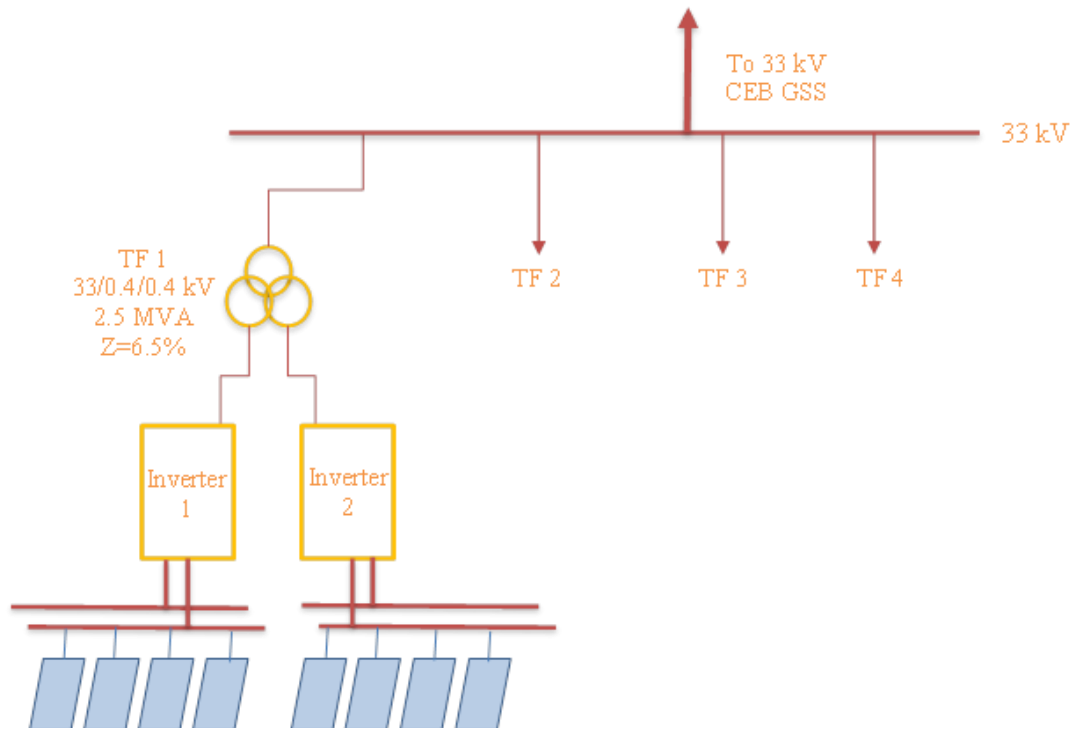

Figure 4.3: Arrangement of a 10 MW solar plant

#### 4.1 Steady state solar model validation

Model validation is an important aspect in power system studies. When carrying out power system studies it is essential to check if the generation models of each power plant's response match with the simulation results. A solar model could be validated against test data, field measurements and manufacturer's reference data. Also, validation must address active or reactive power capability, active or reactive power controls and protection for different output conditions (i.e. partial output and full output).

The dynamic model of the solar power plant is validated against reference data. Therefore, power flow studies (or steady state analysis) must be carried out first. In load flow studies solar plants are represent as a normal synchronous generator.

The power flow representation of a solar plant includes [17]:

- An explicit representation of the interconnection transmission line, if one exists.
- An explicit representation of all station transformers.
- An equivalent representation of the collector system.
- An equivalent generator step-up (GSU) transformer with a scaled MVA rating.
- An equivalent generator scaled to match the total capacity of the plant.

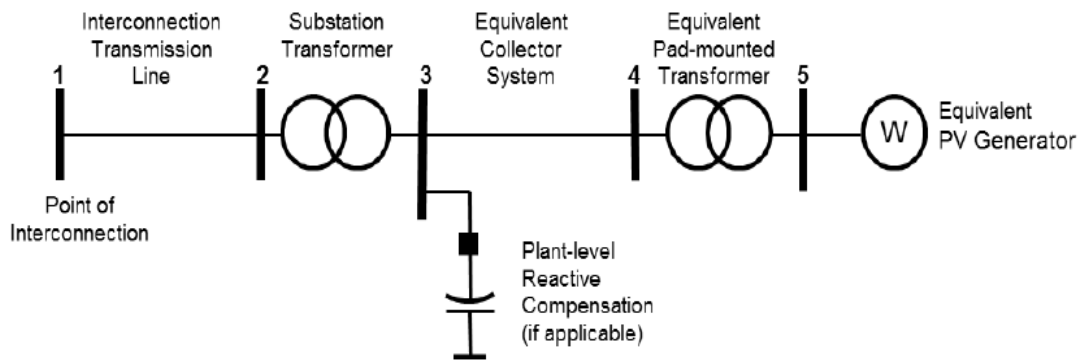

Figure 4.4: Single-machine equivalent representation solar plant

Here, the total generating capacity of the solar plant will be included in the equivalent PV generator. The equivalent pad-mounted transformer represents all step-up transformers, while the equivalent collector system models the aggregate effect of all power lines in the solar plant.

Load flow studies outputs after modeling the solar plant and the simulation results should be approximately match with the load flow profile at the point of interconnection, real and reactive power losses in the collector system and voltage characteristics at the terminal.

Data required to model each of the components of the PV plant single-machine equivalent representation are as follows.



Table 4.1: Data required to model a single-machine equivalent solar plant [17]

Component	Data required
Interconnection Transmission Line	<ul style="list-style-type: none"> <li>• Nominal voltage</li> <li>• Positive-sequence line parameters (R, X, B)</li> <li>• Line ratings (Rate A, Rate B, Rate C)</li> </ul>
PV Plant Station Transformer	<ul style="list-style-type: none"> <li>• Transformer nominal voltage of each winding</li> <li>• Positive-sequence impedance</li> <li>• Tap ratios</li> <li>• Regulated bus and set point</li> <li>• Ratings (Rate A, Rate B, Rate C)</li> </ul>
Equivalent Collector System	<ul style="list-style-type: none"> <li>• Positive-sequence line parameters (R, X, B)</li> <li>• Line ratings (Rate A, Rate B, Rate C)</li> <li>• Total no of branches in the collector system</li> </ul>
Equivalent PV Generator Representation	<ul style="list-style-type: none"> <li>• Maximum and minimum active power output</li> <li>• Maximum and minimum reactive power output</li> <li>• Source impedance</li> <li>• Power factor</li> <li>• Terminal voltage</li> </ul>

## 4.2 Dynamic model validation

Dynamic model validation of a solar plant initiates with collecting available data from commissioning tests, field tests, and grid disturbances as well as mode of operation of the plant in order to match the simulation output. Model parameters could be extracted from inverter manufacturer, plant developer and plant operator. Among all the model parameters, reduction of a subset of parameters which are available for tuning, or estimation is essential and an optimization method or manual estimation could be used for model parameter tuning.

The Western Electricity Coordinating Council (WECC) Renewable Energy Modeling Task Force (REMTF) has developed a set of dynamic models for renewable energy

power plants using a modular approach. The overall model structure is shown in , below. It comprises of three models [18];

- REGC\_A: The generator model to provide current injections into the network solution.
- REEC\_B: The electrical control model for local active and reactive power control
- REPC\_A: The plant controller model to allow for plant-level active and reactive power control

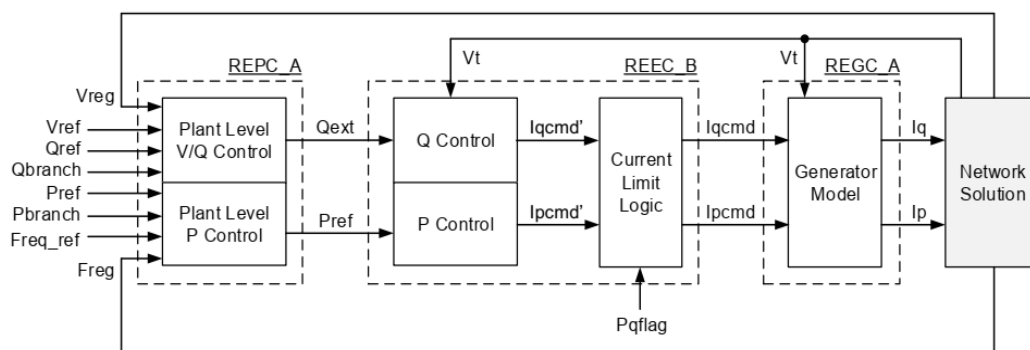

Figure 4.5: Dynamic model for renewable energy power plant [18]

The dynamic model of the solar plant consists of three modules and contains about 75 unique parameters. It is essential to fix as many parameter values as possible before beginning a parameter estimation procedure. Then the free values are tuned.

Only control gains could be considered as free parameters, because having other parameters such as time constants etc. would result in near identical outputs for given input data sets. Therefore, in order to minimize the misperception, the free parameter set is limited to only control gains.

Among approximately 75 parameters in all three modules, there are 11 control gains which could be selected as free parameters. The Table 4.2 below depicts those parameters according to their module (electrical control or plant controller) and whether they affect real or reactive power. In very rare occasions it requires all of these 11 control gains as free parameters [18].

Table 4.2: Division of control gains among electrical controller and plant controller

Real Power		Reactive Power	
REEC_B	REPC_A	REEC_B	REPC_A
-	$K_{pg}$	$K_{qv}$	$K_p$
-	$K_{ig}$	$K_{qp}$	$K_i$
-	$D_{dn}$	$K_{qi}$	-
-	$D_{up}$	$K_{vp}$	-
-	-	$K_{vi}$	-

Most often implementations won't use the real power control loop in REPC\_A, and this reduces the size of free parameter set to seven. If the plant is strictly local control (i.e. without a plant controller (REPC\_A)), the free parameter set limits to five and these five parameters are once again categorized according to the operation mode of the plant as shown in Table 4.3 below.

Table 4.3: Control gain categorization according to the operation mode of the plant

REEC_B			Free Parameters
pflag	vflag	qflag	Local
0	0	1	$K_{qv}, K_{vp}, K_{vi}$
0	1	0	$K_{qv}$
0	1	1	$K_{qv}, K_{qp}, K_{qi}, K_{vp}, K_{vi}$
1	1	0	$K_{qv}$

The reactive power control mode of the solar plant is depicted using the combination of the power factor (pflag), voltage control (vflag), and reactive power control (qflag) flags.

pflag :        plant regulate its output to maintain a constant local power factor  
                   if yes, set pflag = 1 or no, set pflag = 0

vflag : plant operate in local voltage control mode  
if yes, set vflag = 0, pfflag = 0 and qflag = 1

qflag : plant operate in local coordinated Q/V control  
if yes, set vflag = 1 and qflag = 0

Once the free parameters are decided, final step is to tune those parameters. This could be done manually with trial and error method or else if there is a more sophisticated situation, an optimization method such as Nelder-Mead method etc. could be used.

#### 4.3 Solar model validation for Hambantota 10 MW solar plant

There are three 10 MW solar power plants are connected to the Hambantota grid substation and the PSS/E solar model of one 10 MW solar plant is validated.

Plant name : Saga solar

Capacity : 10 MW

Connection : Via a dedicated 5.5km, 33 kV lynx transmission line to Hambantota GSS

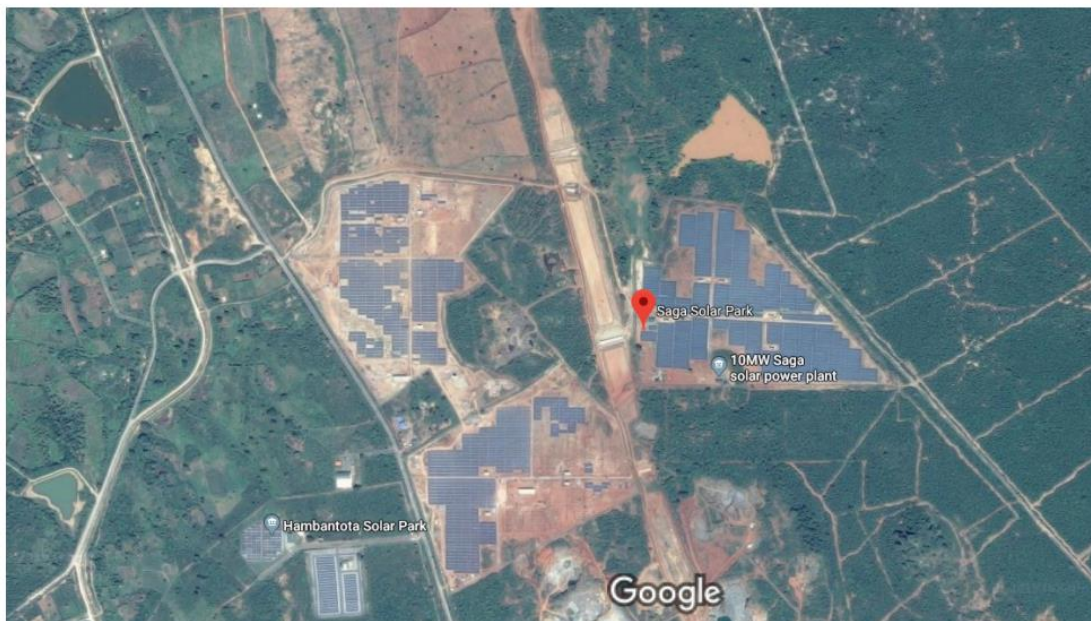

Figure 4.6: Spread of Saga solar park

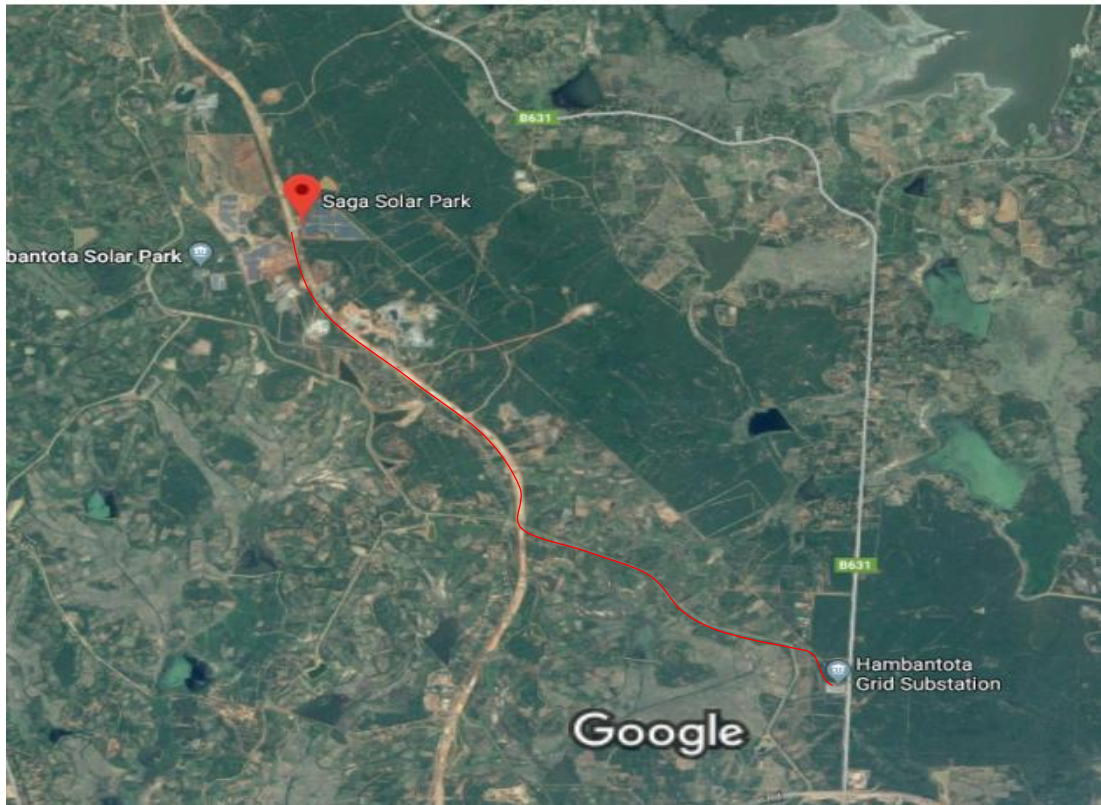

Figure 4.7: Transmission line from the solar plant to Hambantota GSS

The 10 MW solar park is connected to the Hambantota Grid Substation with a dedicated 33 kV feeder (F-12) where no electrical load is connected, via dedicated 5.5 km lynx overhead transmission line.

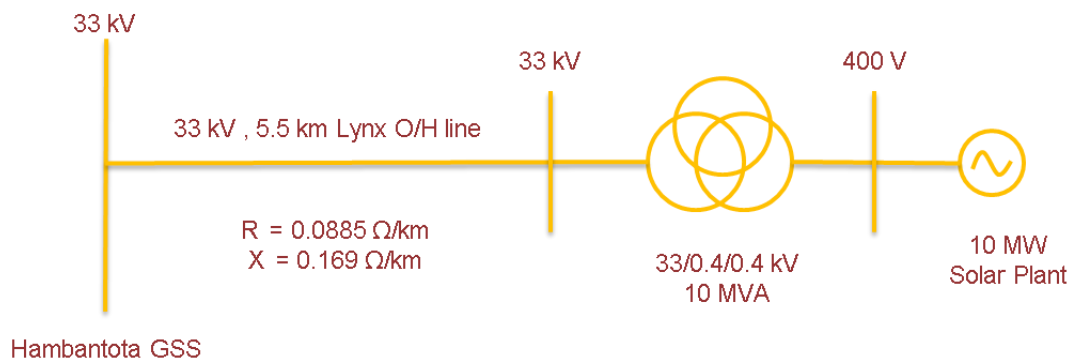

Figure 4.8: Single circuit arrangement of the power plant connection

As per the electrical drawing of 10 MW Saga Solar PV plant in , the plant is connected via four numbers of three winding step-up transformers 33/0.4/0.4 kV (YNd11d11) where the primary side (0.4 kV) is Delta connected and the secondary side (33 kV) is Neutral grounded Star connected.

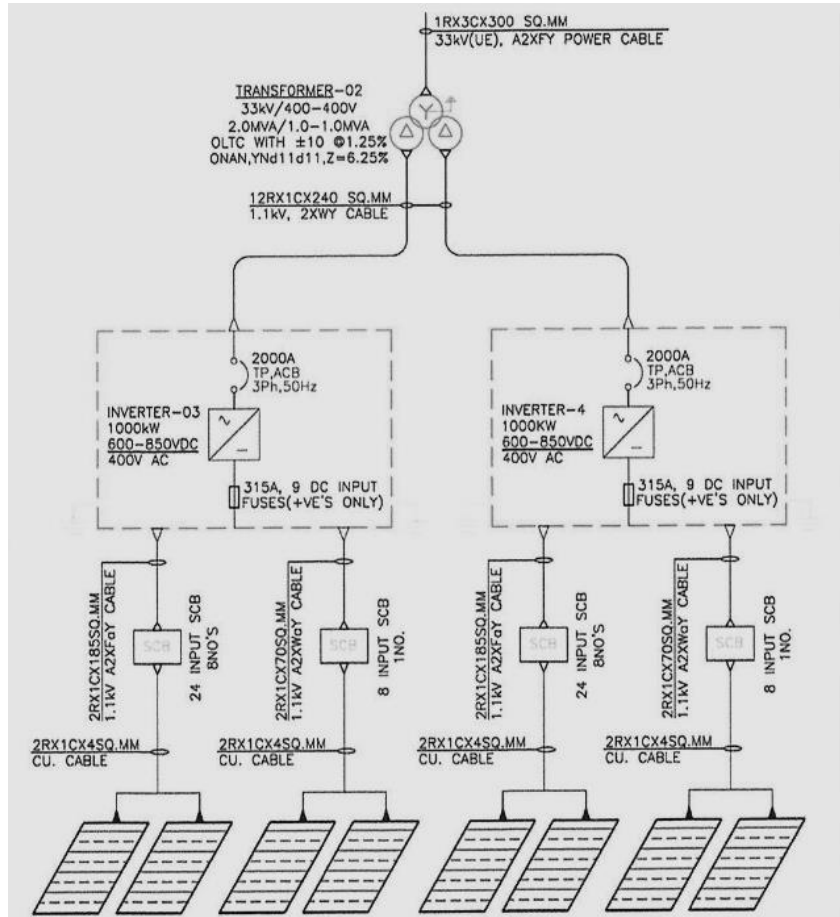

Figure 4.9: Electrical drawing of Saga solar plant

In order to validate the dynamic model of the solar plant, plant's real and reactive power variation with voltage variation at a disturbance has been modeled. A 33 kV line tripping moment was captured and its' active and reactive power output variation was recorded and compared with simulation results.

Since the Hambantota solar power plant doesn't comprise of a plant controller, the solar model is composed of the generator model (REGC\_A) and the electrical controller model (REEC\_B). The parameters considered for the solar model is given in Appendix B.

With this arrangement, the free parameters which are tunable are limited to  $K_{qv}$ ,  $K_{qp}$ ,  $K_{qi}$ ,  $K_{vp}$  and  $K_{vi}$ . The power plant doesn't regulate its' output to maintain the power factor ( $pflag = 0$ ) and the plant operates in local voltage control mode ( $vflag = 0$  and  $qflag = 1$ ). Therefore, the free parameters which are tunable could be finalized to  $K_{qv}$ ,  $K_{vp}$  and  $K_{vi}$ .

The real and reactive power output curves before tuning the parameters are shown below in Figure 4.10 and Figure 4.11 respectively.

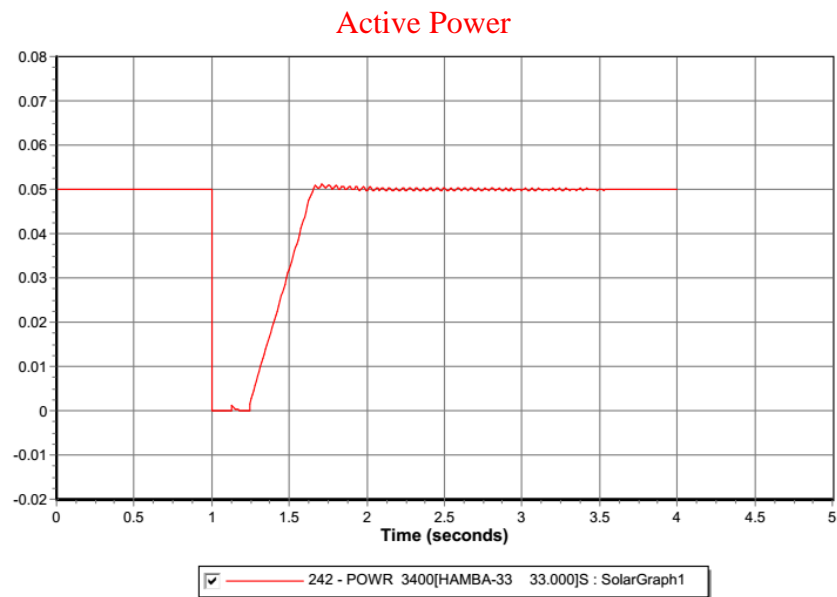

Figure 4.10: Active power output of solar plant before tuning

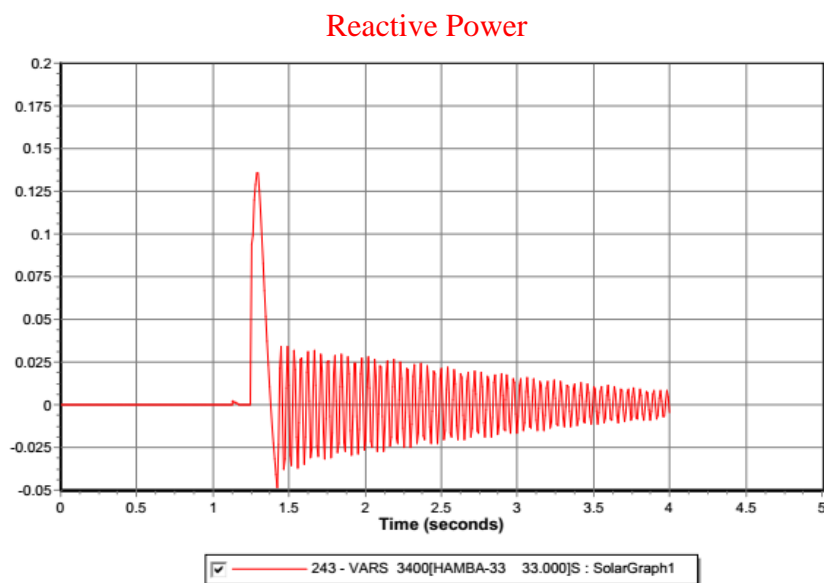

Figure 4.11: Reactive power output of solar plant before tuning

The following control gains have been manually tuned in order to match the actual scenario records.

$K_{qv}$  : Reactive current injection gain, p.u.

$K_{vp}$  : Local voltage regulator proportional gain, p.u.

$K_{vi}$  : Local voltage regulator integral gain, p.u.

While tuning process in progress, it was cleared that changing  $K_{qv}$  doesn't change the real and reactive power output curves. Therefore,  $K_{vp}$  and  $K_{vi}$  have been manually tuned using trial and error until the results match. The initial values of free parameters are;  $K_{vp} = 18$

$K_{vi} = 5$ .

The output variations according to the changes of control gain values are shown in Figure 4.12 and Figure 4.13.

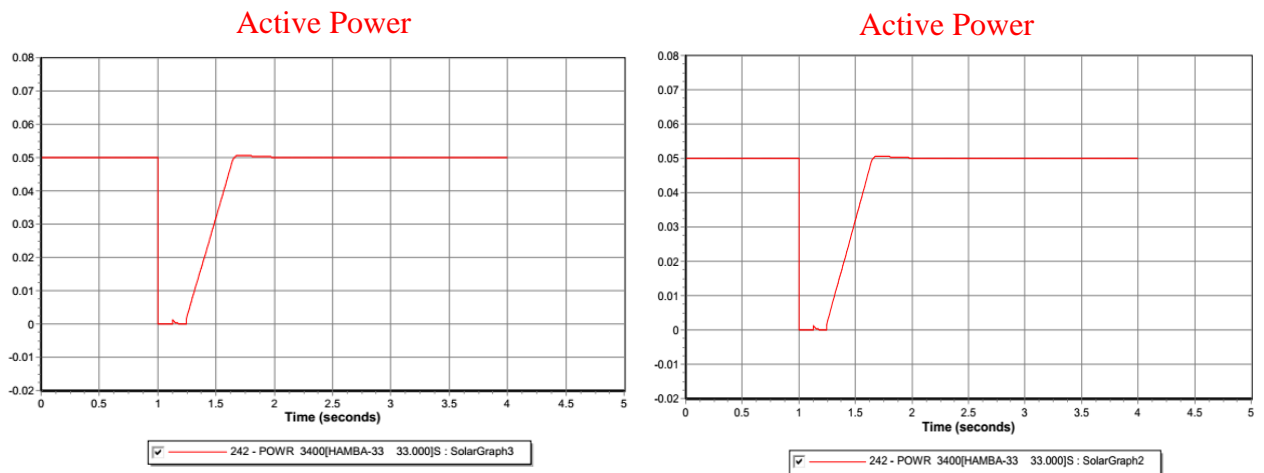

Figure 4.12: Active power output variation with gain value changes

It can be seen that with the change of  $K_{vp}$  and  $K_{vi}$ , active power output doesn't tend to vary but the reactive power output varies drastically.



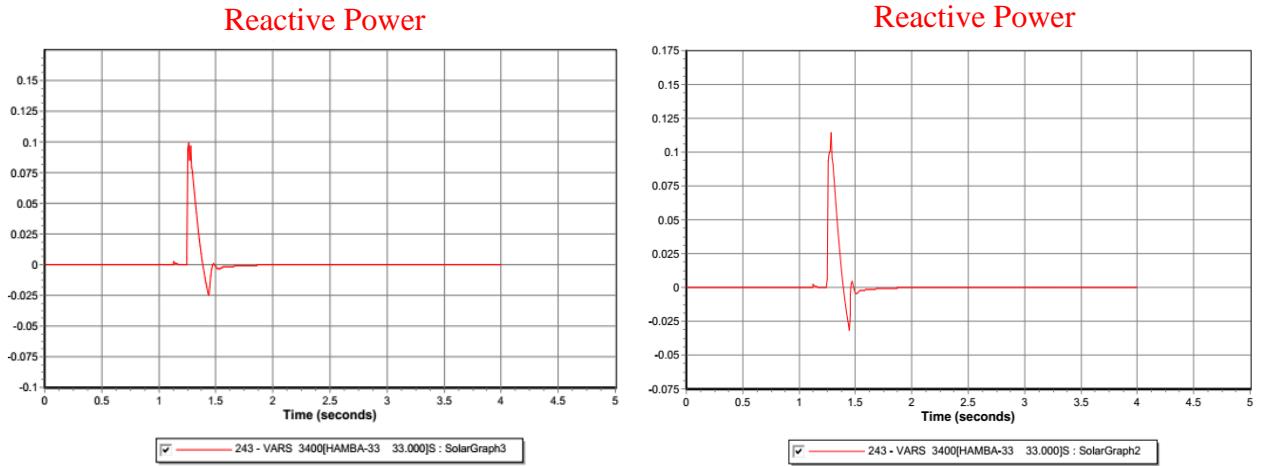

Figure 4.13: Reactive power output variation with gain value changes

At the end of the tuning process, it has been finalized the values for the control gains as;

$$K_{vp} = 10.6$$

$$K_{vi} = 2.1.$$

The real and reactive power graphs of actual incident and simulation are as shown below Figure 4.14 and Figure 4.15.

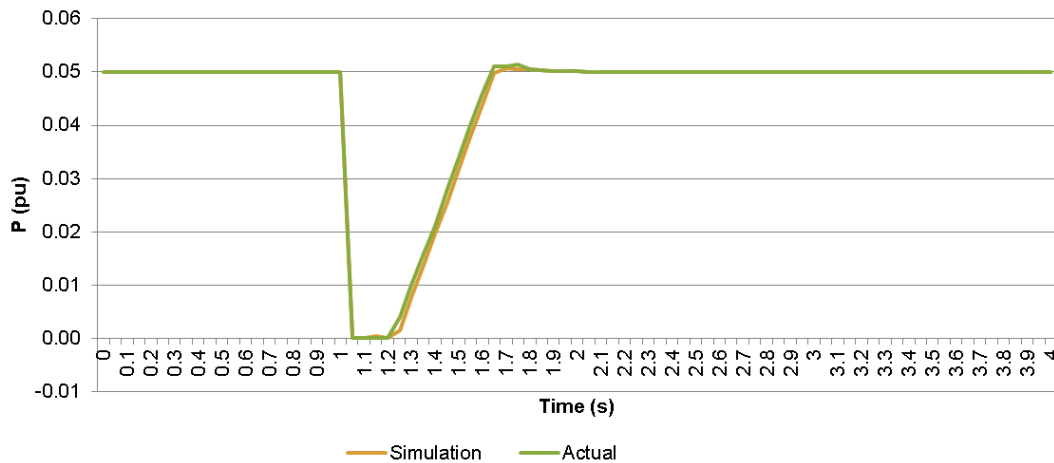

Figure 4.14: Comparison of Simulation vs Actual active power output

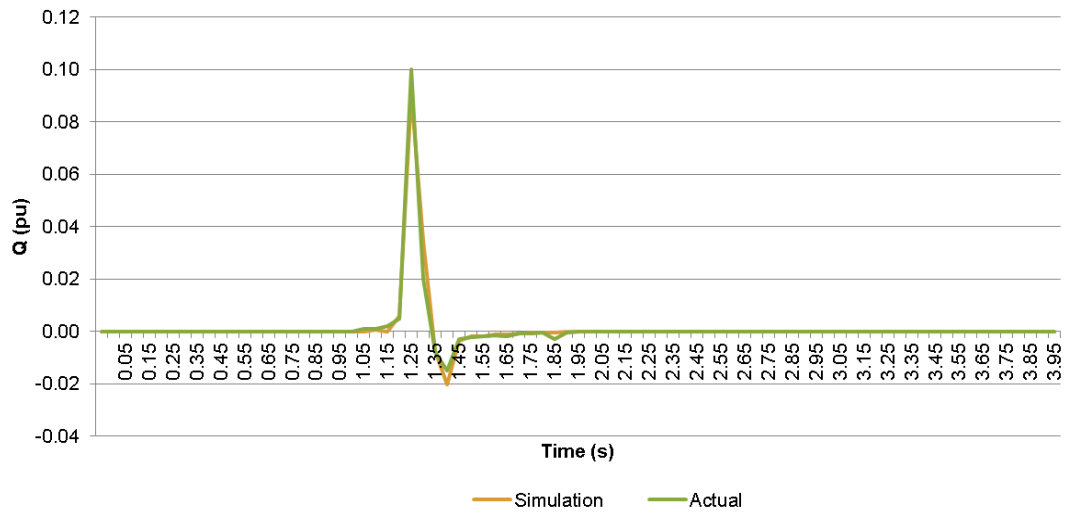

Figure 4.15: Comparison of Simulation vs Actual reactive power output

### BATTERY ENERGY STORAGE SIZING

---

Solar power systems are spreading around the world due to their decreasing costs, increasing environmental concerns and fossil fuel resources depletion. Reasons behind the rapid increase of solar generation are short construction period, low operational complexity as well as costs, sustainability and fuel price independency.

However, photovoltaic power output experience high variability due to the intermittent nature of solar irradiance caused by cloud cover over solar plants. This cloud passing could cause power fluctuations with nearly unpredictable fast variations (from seconds to few minutes), creating difficulties to maintain the frequency and voltage stability in power grids including solar plants. This issue becomes prominent for small grids, mainly islands; as smoothing effect caused due to geographical dispersion is minimal.

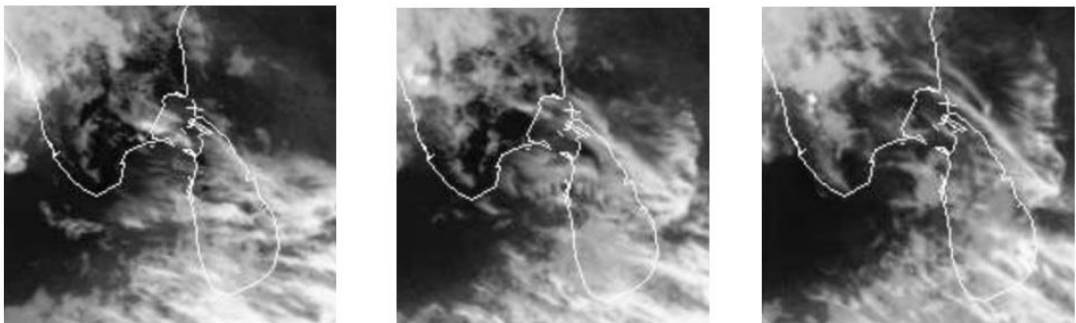

Figure 5.1: Cloud cover variation over Sri Lanka on three different days

Solar power output measured from Hambantota 10 MW solar power plant on sunny day and cloudy day is shown below in . For controlling the grid instability, ramp rate regulations to the power supplied should be imposed at the point of common coupling. In order to accomplish such regulation a Battery Energy Storage System (BESS) could be used, which has the ability to inject or absorb power when solar power decrease or increase, faster than the stipulated ramp rate limit.

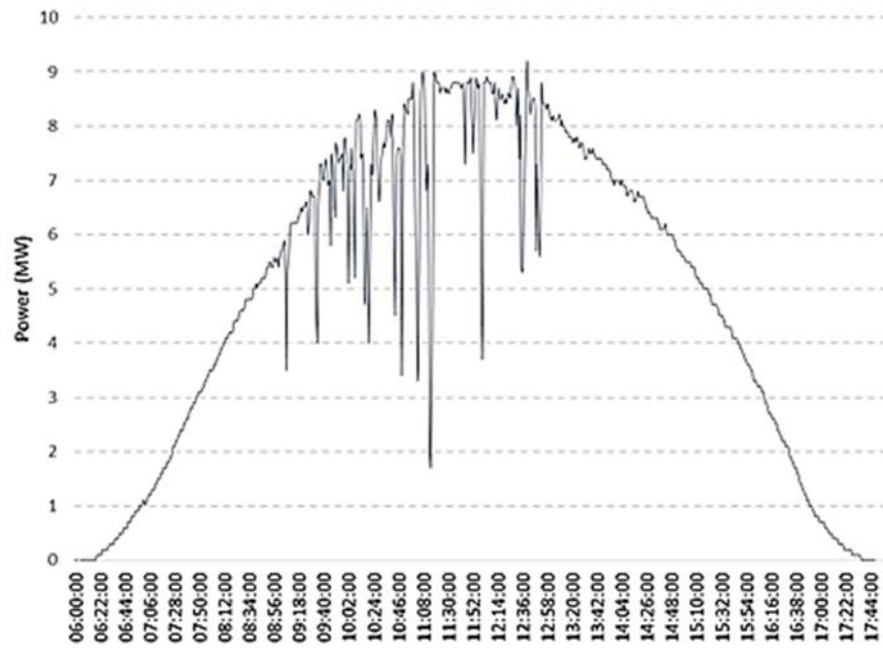

Figure 5.2: Solar output power variation on a normal day

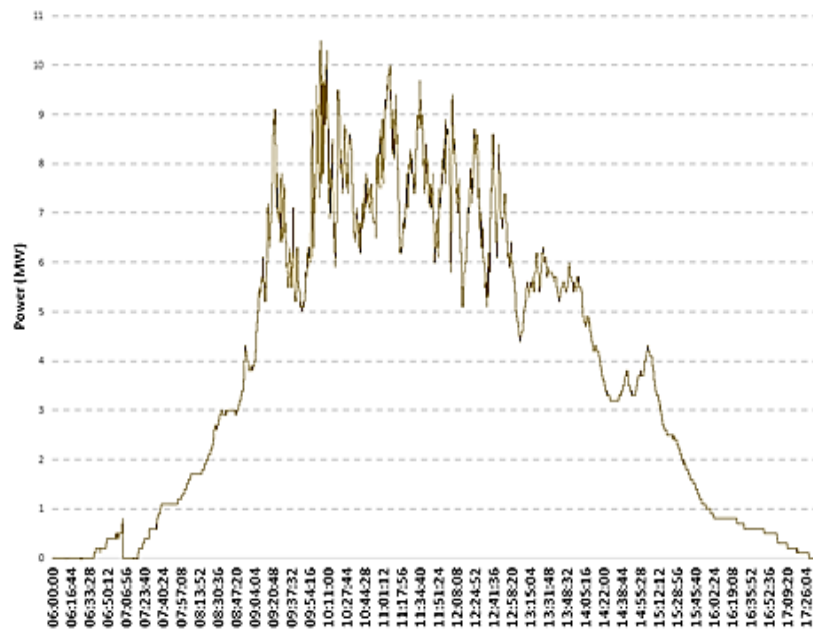

Figure 5.3: Solar output power variation on a cloudy day

When using battery energy storage systems, it is essential to reduce the size of the battery to the minimal size due to the high cost of power conversion systems and batteries. Charging, discharging, control strategy etc. directly affects the required size of the power conversion system and energy rating of the battery.

The size of the BESS has a direct relationship to;

- Total generation capacity of solar plant
- Field size or geographical dimensions of solar plant
- Average and worst rate of solar power variations (due to cloud passing)
- Acceptable ramp rate limit due to limits of grid interconnection or grid code

The size of the BESS is calculated using ramp rate control strategy which is based on a model developed by Alam et al. [19] and Brian de Beer [20] as shown below in Figure 5.4.

Since the BESS is sized to mitigate solar intermittency, the first step is to calculate solar power output variations. Therefore, solar ramp rate between every minute is calculated using;

$$RR_{PV}(k) = \frac{P_{PV}(k) - P_{PV}(k-1)}{t_k - t_{k-1}}$$

The allowable ramp rate of solar power output should be below 10%/min. This value hasn't been added to the grid code yet, but currently at discussion.

$$\therefore RR_{des} = 10\%/minute$$

$$RR_{des} = 10 \times \frac{10}{60} MW/second$$

$$RR_{des} = 0.01667MW/second$$

If the calculated solar power ramp rate is lower than the desired ramp rate, BESS is not required as the power fluctuation could be tolerated by the grid. But when the solar power output ramp rate is higher than the desired level, it is required to utilize a BESS in charging or discharging mode to smooth the power output.

According to the solar ramp rate, required charging or discharging rate (or ramp rate of BESS) could be calculated. Ramp rate of BESS leads to the calculation of power of BESS required. Out of all the calculated BESS power, maximum quantity of every day is recorded. By carrying out this process for every day, for a data set of one year, will lead to calculate the optimal size of BESS required.

$$RR_{batt} = \frac{1}{\eta_{inv}} \times (RR_{des} - RR_{PV}); \quad \eta_{inv} = 0.95$$

$$P_{batt} = S \times [P_{batt}(k-1) + RR_{batt}(k) \times \{t(k) - t(k-1)\}]$$

$$P_{batt}^{min} = \max\{P_{batt}^1, P_{batt}^2, P_{batt}^3, \dots, P_{batt}^n\}$$

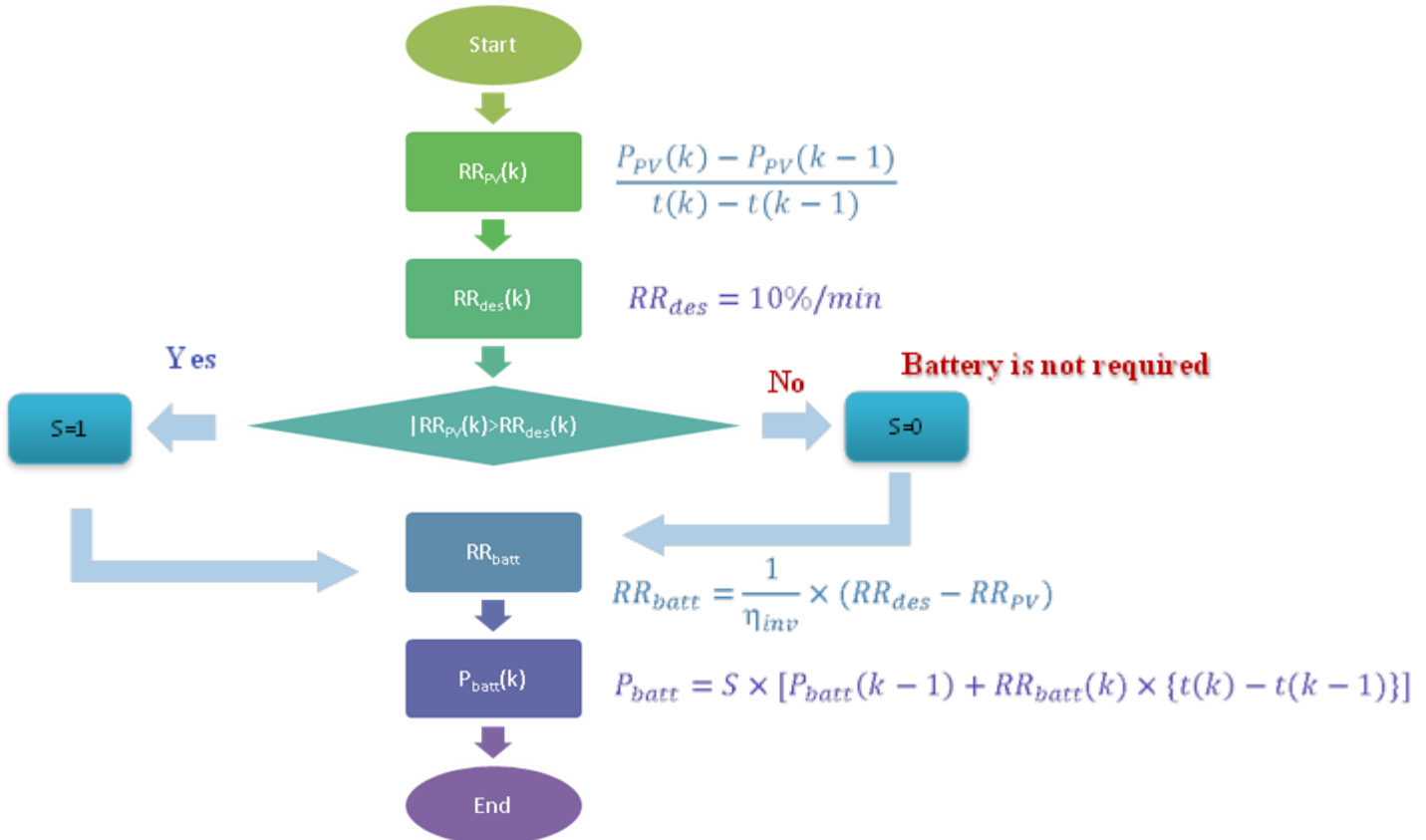

Figure 5.4: BESS sizing methodology

1-second data was collected directly from the Hambantota solar power plant for 42 days. Since this isn't sufficient to calculate the size of BESS, 1-minute data was collected through the Sustainable Energy Authority of Sri Lanka. For a single day, the power output of the solar power plant has been plotted in 1-second interval and 1-minute interval in below Figure 5.5.

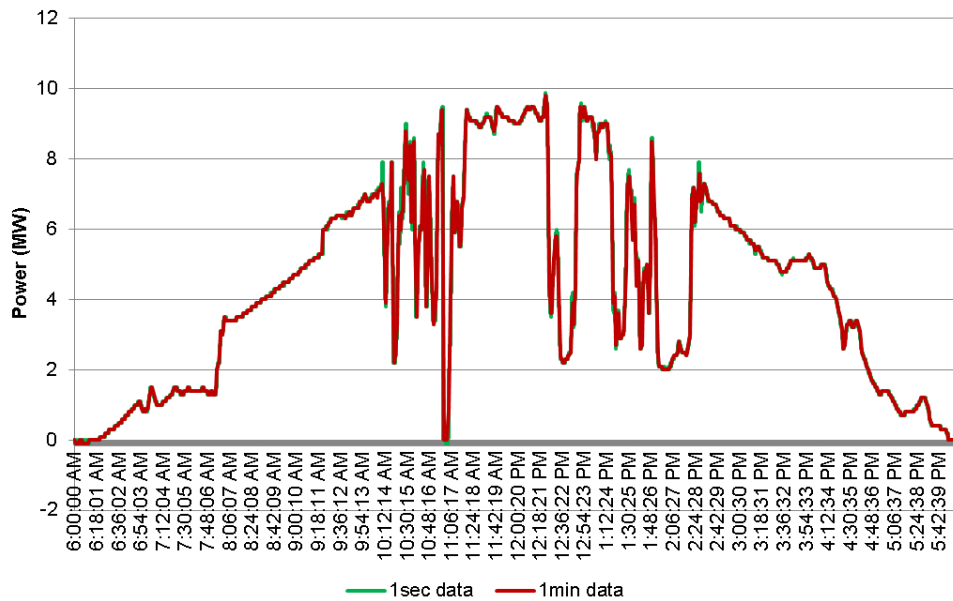

Figure 5.5: 1-second and 1-minute power output of 10 MW solar plant for a single day

According to the above figure, it can be seen that 1-second power ramp rate could be captured from 1-minute data as well. Therefore 1-minute data records for a complete year have been considered to calculate the BESS size.

For every minute interval solar power ramp rate has been calculated and checked if it's within the required range and then power requirement of the BESS has been calculated for a complete year. Final results of some selected days from that year are shown below.

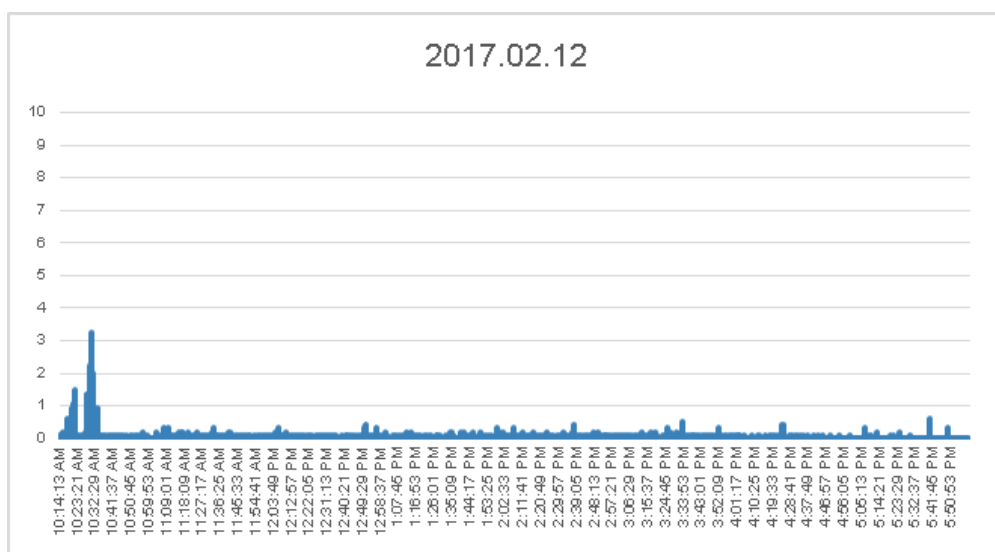

Figure 5.6: Solar power output variation throughout the day on 12<sup>th</sup> February

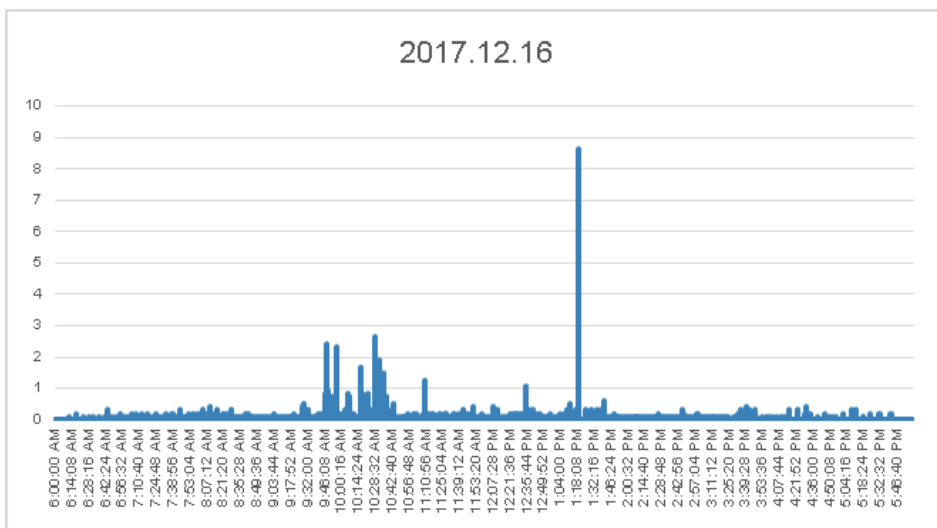
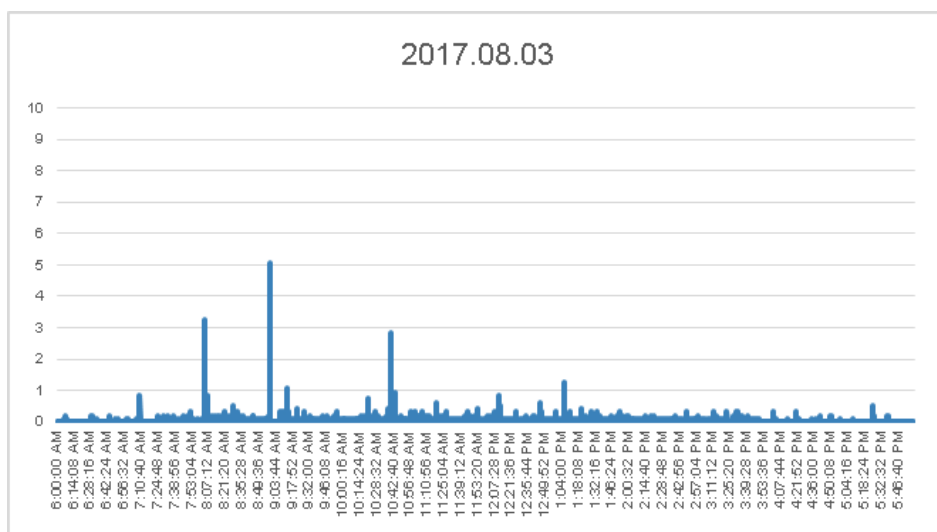
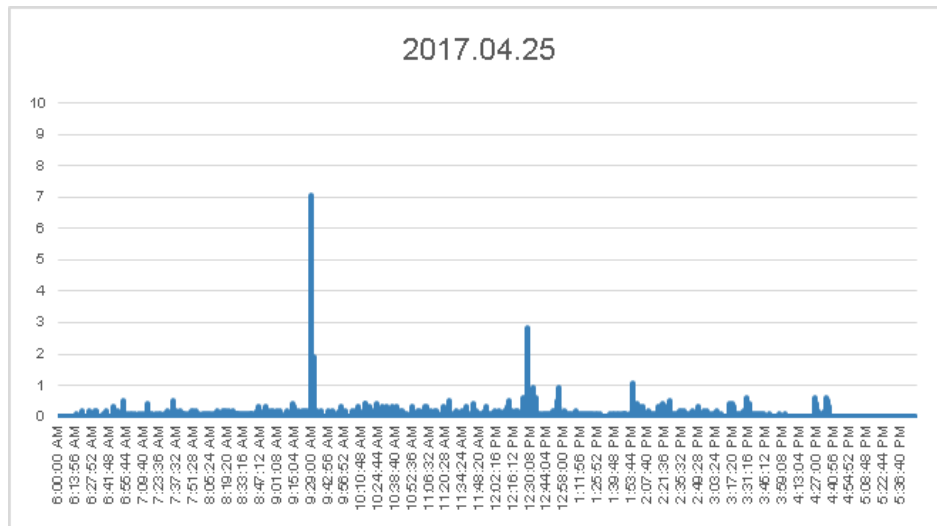

Figure 5.7: Solar power output variation throughout the day on 25<sup>th</sup> April, 03<sup>rd</sup> August and 16<sup>th</sup> December



By carrying out calculation for a complete year, statistically the required size of a BESS could be decided. As shown in below Figure 5.9 it can be seen the maximum required size of BESS is 9 MW for the 10 MW solar power plant.

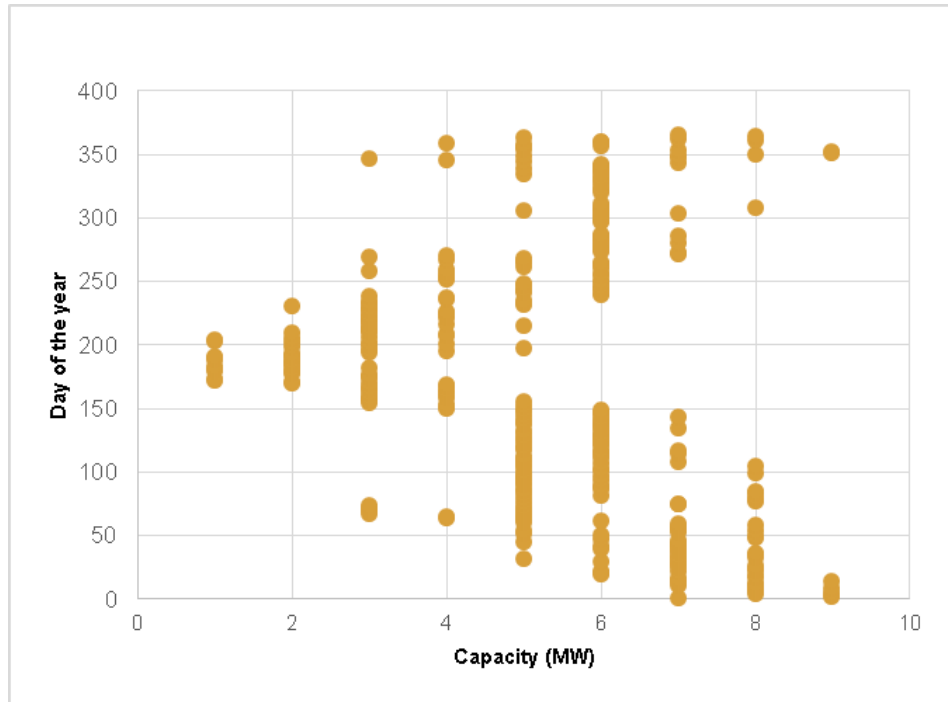

Figure 5.9: Battery capacity requirement variation throughout the year

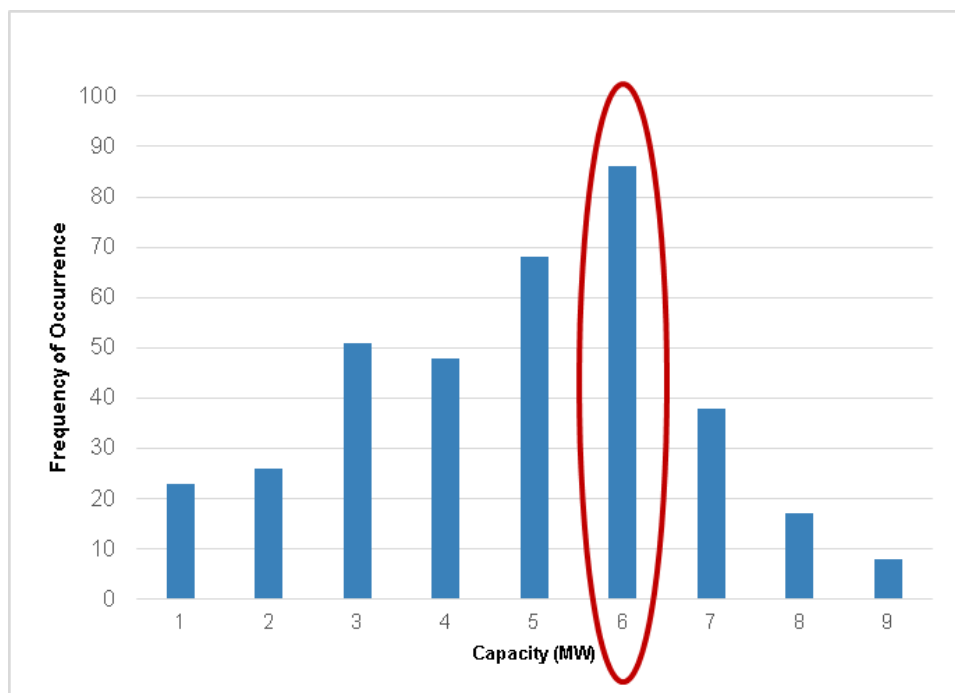

Figure 5.8: Battery capacity requirement variation

But the cost of a BESS directly depends on its size. Therefore, it is required to calculate the optimal size of a BESS considering the cost. After analyzing the results for a complete year, the optimal size of the BESS could be concluded as 6 MW.

### **MAXIMUM SOLAR ABSORPTION CAPACITY THE YEAR 2025 INTO THE SRI LANKAN TRANSMISSION NETWORK**

---

Intermittent sources such as solar and wind cannot be controlled or accurately predicted. Since the energy generated from these kinds of sources are not dispatchable, it is required to use other types of controllable and dispatchable resources to balance the supply and demand of electric energy. Conventional resources must then be used to follow the net of renewable energy delivery with the electric demand and to provide essential services such as regulation and contingency reserves that ensure power system reliability. This increases the required quantity of conventional generation, and as a result additional costs may take place.

In long term planning it is essential to maintain power reliability to meet the increasing demand with the planned generation. Since Sri Lanka is an island with an isolated grid, it is required to analyze the integration capacity of renewable energy sources due to their intermittent nature. The natural variability or unpredictable weather conditions and intermittency of cloud cover can cause large variations of power generated at a moment. Network level problems occur where changes in solar power generation on a power network are unable to be balanced by the existing generation mix over the time frame of the change due to limited flexibility to follow the net demand. This could cause frequency issues in the network which could lead to system collapses such as blackouts, brownouts, outages etc. Therefore, these variations limit the level of penetration of variable generation resources integrated into the existing electric grid.

Generated power variation for solar plants depends on the size of the plant. For smaller solar plants (less than 1 MW) the output power variation is faster (in seconds scale) and creates voltage and harmonic issues in the low voltage network. When the size of the solar power plant is larger, the variations are in several seconds or minutes time scale as the variation is slower. In addition to the normal stability studies, short time

frequency stability of the system should be studied when substantial amount of solar power is integrated to the system.

To carry out power system stability studies with the upcoming solar plants, it was required to carry out studies in day time scenarios. Therefore, maximum NCRE day peak scenario was selected to carry out studies to calculate the maximum solar absorption capacity by year 2025. According to the Least Cost Long Term Generation Expansion Plan (LCLTGEP) 2018 – 2037 published by Ceylon Electricity Board, there will be four new combined cycle power plants (2 Gas turbines + 1 Steam turbine each) with LNG as their fuel and two gas turbines in Kelanitissa. These new power plants will highly help to reduce the impact of intermittent energy resources and improve the system stability while integrating high amount of wind and solar power into the Sri Lankan power grid.

The base case generation plan considered for the study is shown below.

Table 6.1: Base case generation plan for the year 2018 - 2037 [1]

YEAR	RENEWABLE ADDITIONS			THERMAL ADDITIONS	THERMAL RETIREMENTS	LOLP %
2018	Mini Hydro Biomass	15 MW 5 MW	Solar 160 MW	100 MW Furnace Oil fired Power Plant * 70 MW Furnace Oil fired Power Plant * 150 MW Furnace Oil fired Power Plant *	8x6.13 MW Asia Power	1.245
2019	Major Hydro Mini Hydro Solar	122 MW 15 MW 95 MW	(Uma Oya HPP) Wind 50 MW Biomass 5 MW	2x35 MW Gas Turbine 1x300 MW Natural Gas fired Combined Cycle Power Plant – Western Region*	-	0.220
2020	Major Hydro Wind Mini Hydro Solar	35 MW 15 MW 105 MW	(Broadlands HPP) (Thalpitigala HPP) (Mannar Wind Park) Wind 120 MW Biomass 5 MW	1x35 MW Gas Turbine	6x5 MW Northern Power	0.237
2021	Mini Hydro Solar	10 MW 55 MW	Wind 75 MW Biomass 5 MW	1x300 MW Natural Gas fired Combined Cycle Power Plant – Western Region	4x17 MW Kelanitissa Gas Turbines	0.107
2022	Major Hydro Mini Hydro Solar	30 MW 20 MW 20 MW 10 MW 6 MW	(Moragolla HPP) (Seethawaka HPP) (Gin Ganga HPP) Wind 50 MW Biomass 5 MW			0.237
2023	Mini Hydro Solar	10 MW 55 MW	Wind 60 MW Biomass 5 MW	1x300 MW New Coal Power Plant (Change to Super critical will be evaluated) 163 MW Combined Cycle Power Plant (KPS-2)*	115 MW Gas Turbine** 4x9 MW Sapugaskanda Diesel Ext.** 163 MW SojitzKelanitissa Combined Cycle Plant *	0.205
2024	Mini Hydro Solar	10 MW 55 MW	Wind 45 MW Biomass 5 MW	1x300 MW New Coal Power Plant (Change to Super critical will be evaluated)	4x18 MW Sapugaskanda Diesel	0.145

YEAR	RENEWABLE ADDITIONS			THERMAL ADDITIONS	THERMAL RETIREMENTS	LOLP %
2025	Major Hydro	200 MW	(Pumped Storage Power Plant)	<b>1x300 MW New Coal Power Plant</b>	4x9 MW Sapugaskanda Diesel Ext.	0.026
	Mini Hydro	10 MW	Wind 85 MW			
2026	Solar	104 MW	Biomass 5 MW	-	4x15 MW CEB Barge Power Plant	0.019
	Major Hydro	200 MW	(Pumped Storage Power Plant)			
2027	Mini Hydro	10 MW	Solar 55 MW	-	-	0.012
	Major Hydro	200 MW	(Pumped Storage Power Plant)			
2028	Mini Hydro	10 MW	Wind 45 MW	<b>1x600 MW New Supercritical Coal Power Plant</b>	-	0.002
	Solar	105 MW	Biomass 5 MW			
2029	Mini Hydro	10 MW	Wind 25 MW	-	-	0.008
	Solar	54 MW	Biomass 5 MW			
2030	Mini Hydro	10 MW	Wind 70 MW	-	-	0.027
	Solar	55 MW	Biomass 5 MW			
2031	Mini Hydro	10 MW	Wind 35 MW	<b>1x600 MW New Supercritical Coal Power Plant</b>	-	0.005
	Solar	54 MW	Biomass 5 MW			
2032	Mini Hydro	10 MW	Wind 45 MW	-	-	0.019
	Solar	55 MW				
2033	Mini Hydro	10 MW	Wind 70 MW	<b>2x300 MW Natural Gas fired Combined Cycle Power Plants - Western Region</b>	165 MW Combined Cycle Plant (KPS) 163 MW Combined Cycle Plant (KPS- 2)	0.023
	Solar	54 MW	Biomass 5 MW			
2034	Mini Hydro	10 MW	Wind 70 MW	-	-	0.108
	Solar	55 MW				
2035	Mini Hydro	10 MW	Wind 70 MW	<b>1x600 MW New Supercritical Coal Power Plant</b>	300MW West Coast Combined Cycle Power Plant	0.058
	Solar	54 MW	Biomass 5 MW			
2036	Mini Hydro	10 MW	Wind 95 MW	<b>1x300 MW Natural Gas fired Combined Cycle Power Plant - Western Region</b>	-	0.057
	Solar	55 MW				
2037	Mini Hydro	10 MW	Wind 70 MW	-	-	0.230
	Solar	104 MW	Biomass 5 MW			
<b>Total PV Cost up to year 2037, USD 14,568 million (LKR 2,168.93 billion)**</b>						

According to the LTGEP by year 2025, following major power plants will be added to the Sri Lankan power system.

Table 6.2: Major power plant additions according to LCLTGEP

Power Plant	Capacity	Location	No of plants	Total capacity
LNG combined cycle	300 MW each	Kerawalapitiya	3	900 MW
LNG combined cycle	300 MW	Hambantota	1	300 MW
Coal	300 MW each	Puttalam	2	600 MW
Gas Turbine	45 MW each	Kelanitissa	2	90 MW
Uma oya	60 MW each	Badulla	2	120 MW

The energy mix according to their source by year 2025 will be as follows.

Table 6.3: Energy mix in year 2025

<b>Energy source</b>	<b>Total capacity by 2025</b>
Mini Hydro	443.6 MW
Dendro	73.5 MW
Wind	729.3 MW
Solar	708 MW
Hydro	1603.5 MW
Coal	1375 MW
LNG	1200 MW
Oil	1067 MW

By year 2025, (according to the Least Cost Long Term Generation Expansion Plan and Long Term Transmission Development Plan) it has been proposed to integrate 1000 MW of solar power into the Sri Lankan power system. Among this solar power 300 MW will be rooftop solar power while the remaining 700 MW will be grid connected.

It has been proposed to construct a 140 MW solar park in Pooneryn, 100 MW in Siyambalanduwa and 80 MW in Hambantota as large scale solar plants. The Pooneryn solar park will be connected to 220 kV voltage from Northern Collector Grid Substation and both Siyambalanduwa and Hambantota solar parks will be connected to 132 kV voltage from Monaragala and Hambantota solar grid substations respectively. Another 276 MW will be connected as 1 MW plants in grid substations all over the country. The planned solar addition by year 2025 is depicted below in Table 6.4: Solar power plants in year 2025

Table 6.4: Solar power plants in year 2025

Bus No	Bus Name	ID	Capacity
3150	AMPA-3 33.000	SD	19
3240	VAVUN-33 33.000	S	10
3240	VAVUN-33 33.000	SD	8
3287	POONERYN-S 33.000	S	70
3288	POONERYN-S 33.000	S	70
3330	MONARA-3 33.000	SD	8
3331	SIYAMBALA-S133.000	S	50
3332	SIYAMBALA-S233.000	S	50
3340	BELIAT-3 33.000	SD	14
3400	HAMBA-33 33.000	S	30
3402	HAMBAN S1 33.000	S	50
3403	HAMBAN S2 33.000	S	30
3404	HAM S 33.000	S	32
3420	HORANA_3 33.000	SD	10
3450	MAHO-3 33.000	SD	20
3460	POLON-3 33.000	SD	9
3470	VAUNAT-3 33.000	S	10
3470	VAUNAT-3 33.000	SD	10
3490	PALLEK-3 33.000	SD	6
3500	KOSGA-3 33.000	SD	10
3551	KOLON-3B 33.000	SD	3
3640	DENIY-3 33.000	SD	10
3650	GALLE-3 33.000	SD	8
3660	EMBIL-3 33.000	SD	10
3670	MATARA-3 33.000	SD	13
3680	KURUN-3 33.000	SD	10
3690	HABAR-3 33.000	SD	10
3700	ANURA-3A 33.000	SD	17
3710	TRINC-3 33.000	SD	7
3720	KILINOC_3 33.000	SD	3
3780	VALACH_3 33.000	S	20
3780	VALACH_3 33.000	SD	8

3800	MATUG-3	33.000	SD	10
3820	ATURU-3	33.000	SD	5
3830	VEYAN-33	33.000	SD	6
3850	PANAD-3	33.000	SD	1
3860	MADAM-3	33.000	SD	5
3900	PANNAL	33.000	SD	16
3960	MAHIYA-3	33.000	S	10
3960	MAHIYA-3	33.000	SD	20

SD : 1 MW solar plants

S : plants with capacity above 10 MW

The forecasted rooftop connected solar 300 MW by year 2025, is distributed among the grid substations as follows.

Table 6.5: Rooftop solar distribution in year 2025

ID	Grid Substation	Solar rooftop (MW)
3301	Kelanitissa	0.29
3302	Kelanitissa	0.29
3550	Kolonnawa (Indoor)	0.18
4435	Sub A (Havelock Town)	11.68
4980	Sub B (Pettah)	0.74
4920	Sub C (Kotahena)	0.38
4750	Sub E (Kollupitiya)	9.35
4760	Sub F (Fort)	0.88
4430	Sub I (Maradana)	0.29
4190	Sub K (Wellawatta)	9.95
4270	Sub M (Slave Island)	2.96
4260	Sub N (Hunupitiya)	5.01
4365	Sub P (Narahenpita)	7.26
4360	Sub Q (Town Hall)	7.35
3700	Anuradhapura	3.05
3690	Habarana	4.47
3705	New Anuradhapura	3.05
3460	Polonnaruwa	3.01
3220	Chemmani	4.93
3730	Chunnakam	4.93
3720	Killinochchi	1.23



3280	Mannar	0.38
3240	Vavuniyawa	0.76
3600	Bolawatta	6.74
3865	Keeriyankalliya	0.07
3680	Kurunegala	6.86
3860	Madampe	2.36
3900	Pannala	1.10
3810	Puttalama	0.16
3370	Wariyapola	0.61
4771	Kandy City	3.62
3535	Kegalle	5.75
3770	Kiribath Kumbura	4.80
3380	Nawalapitiya	0.40
3520	Nuwara Eliya	0.32
3490	Pallekele	8.11
3390	Ragala	0.06
3530	Thulhiriya	1.20
3200	Ukuwela	1.52
3120	Wimalasurendra	0.99
3150	Ampara	5.74
3480	Kappalthurei	0.23
3610	Pottuvil	1.53
3711	Serunuwara	0.05
3710	Trincomalee	0.42
3780	Valachchenai	2.19
3470	Vavunathivu	1.14
3910	Aniyakanda	2.38
3570	Biyagama	3.41
3575	Biyagama Zone	2.68
4875	Ja-Ela LECO	2.38
3440	Katunayaka	1.18
4445	Katunayaka LECO	1.77
3870	Kelaniya	1.25
3305	Kerawalapitiya	0.53
3991	Kirindiwela	2.13
3580	Kotugoda	8.23
3835	Mirigama	0.47

3010	Negombo	0.58
3590	Sapugaskanda	1.78
3830	Veyangoda	3.59
3630	Balangoda	0.37
3660	Embilipitiya	4.90
3635	Kahawatta	0.09
3411	Kalawana	0.16
3020	Maliboda	0.13
3740	Rathnapura	0.71
3030	Wewalwatta	0.14
3620	Badulla	1.81
3960	Mahiyanganaya	1.05
3330	Monaragala	2.54
3525	Welimada	0.04
3820	Athurugiriya	4.12
3971	Homagama	3.50
3420	Horana	1.92
3050	Kesbewa	8.61
3551	Kollonnawa (Outdoor)	0.15
3500	Kosgama	1.82
3040	Malabe	2.22
3976	Millaniya-Wagawatta	0.13
3975	Millewa	3.67
3560	Pannipitiya	10.51
4845	Rajagiriya	7.72
3510	Seethawaka	1.21
3840	Sri Jayawardanapura	11.36
3880	Ambalangoda	2.10
3882	Baddegama	1.21
3340	Beliatta	1.98
3640	Deniyaya	0.09
3650	Galle	8.10
3400	Hambantota	3.59
3670	Matara	9.53
3060	Tissamaharama	1.26
3655	Weligama	8.12
3890	Dehiwala	11.76

3290	Kalutara	0.57
3800	Mathugama	0.67
3850	Panadura	1.71
3790	Ratmalana	9.60

### 6.1 Effect of solar ramp rate and short-term frequency stability

The power ramping of solar plant output due to the change of cloud cover is shown below Figure 6.1 and Figure 6.2.

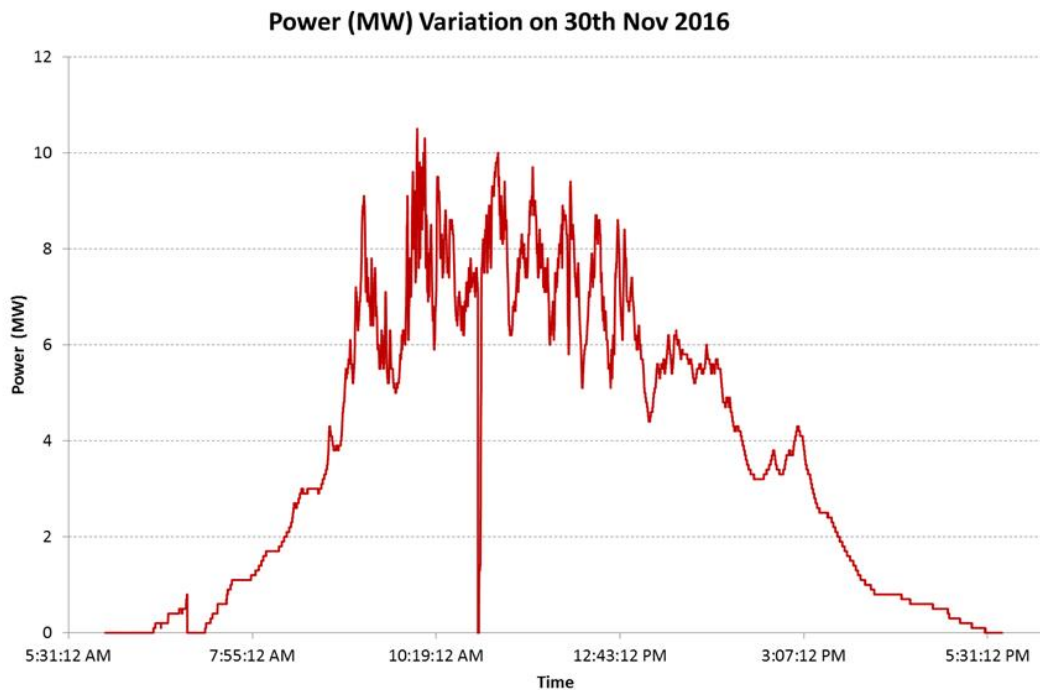

Figure 6.1: Power variation of 10 MW solar power plant on a single day

As the clouds are in move, it will cover one location at a time and will move forward next. Therefore, the ramp rate will vary randomly. It also depicts that output power variability of a single PV unit in one location cannot be directly used to represent output variability of solar plants which are spread out all over the island.

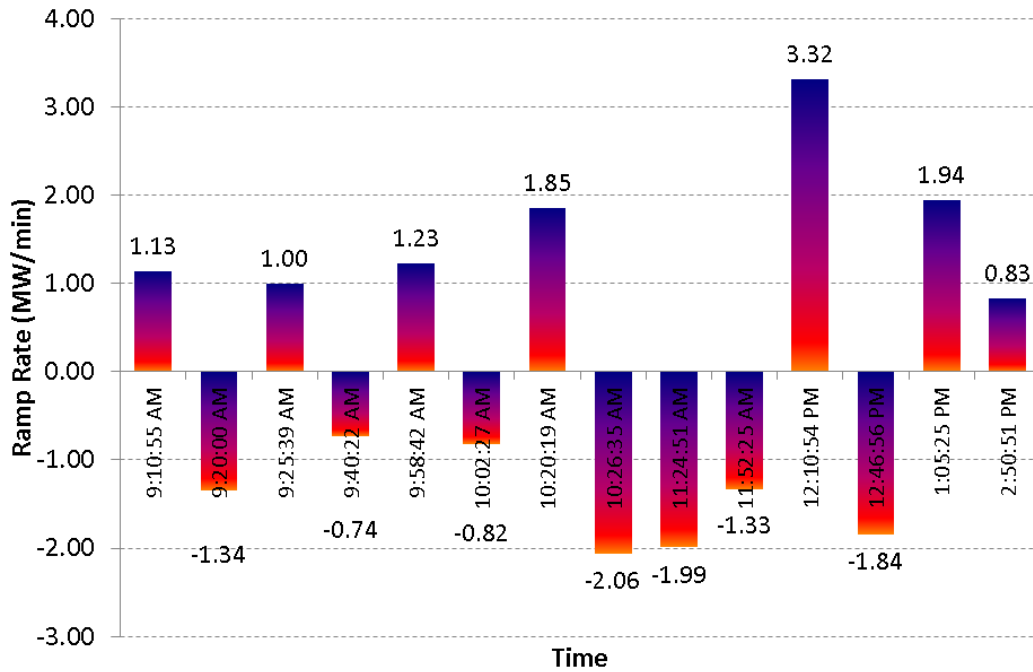

Figure 6.2: Ramp rate variation of the same day

The solar ramp rate depends on the following factors [21].

**Geographical spread:** Since the solar parks are geographically spread out all over the country, total solar power output variability decreases. Cloud coverage over two or more solar parks will not be identical at the same moment.

**Time scale:** In general, clouds move slowly and it takes several minutes to pass few kilometers. Therefore, power variation could be cancel-out for two parks located few kilometers apart. Hence the combined effect will appear as constant in second scale and will have a smoothing effect in the minute scale.

**Weather Patterns:** Cloud speed has a significant impact on the solar power variability. Faster moving clouds require larger geographic distances between the solar farms to smooth out the solar power output variability.

Currently it has been considered as thumb rule, that a 10 MW solar plant requires about 50 acres (0.2025 km<sup>2</sup>) land area.

For the calculation purpose let's consider the square plot of solar park with one side is 'a'.

$$a^2 = 0.2025 \text{ km}^2$$

$$a = 0.45 \text{ km} = 450 \text{ m}$$

Typical cloud speed in Sri Lanka is 25 km/hour. Therefore, the time take for a cloud to pass a 10 MW solar park will be,

$$t = \frac{0.45 \text{ km}}{25 \frac{\text{km}}{\text{hour}}}$$

$$t = 0.018 \text{ hour} = 1.08 \text{ min}$$

Following table shows the required land area and time taken by a cloud to pass a solar park completely.

Table 6.6: required land area and time taken by a cloud to pass with the capacity of solar plant

Capacity (MW)	Area requirement (km <sup>2</sup> )	Time to pass a cloud with a speed of 25 km/h
10	0.2025 (50 acres)	1.1 min
20	0.4050 (100 acres)	1.5 min
30	0.6070 (150 acres)	1.9 min
50	1.0117 (250 acres)	2.4 min
100	2.0234 (500 acres)	3.4 min

If the solar plants have been spread geographically, then the effective solar power ramp up and down rate will decrease. If the distance between solar PV plants are about 10 km, then it takes 24 min for a cloud to pass from one solar location to another. The sites which we have identified for solar PV plant development are given in Figure 6.3. It is clear that most of the sites are located more than 10 km distance apart and effective solar ramp rate is small.

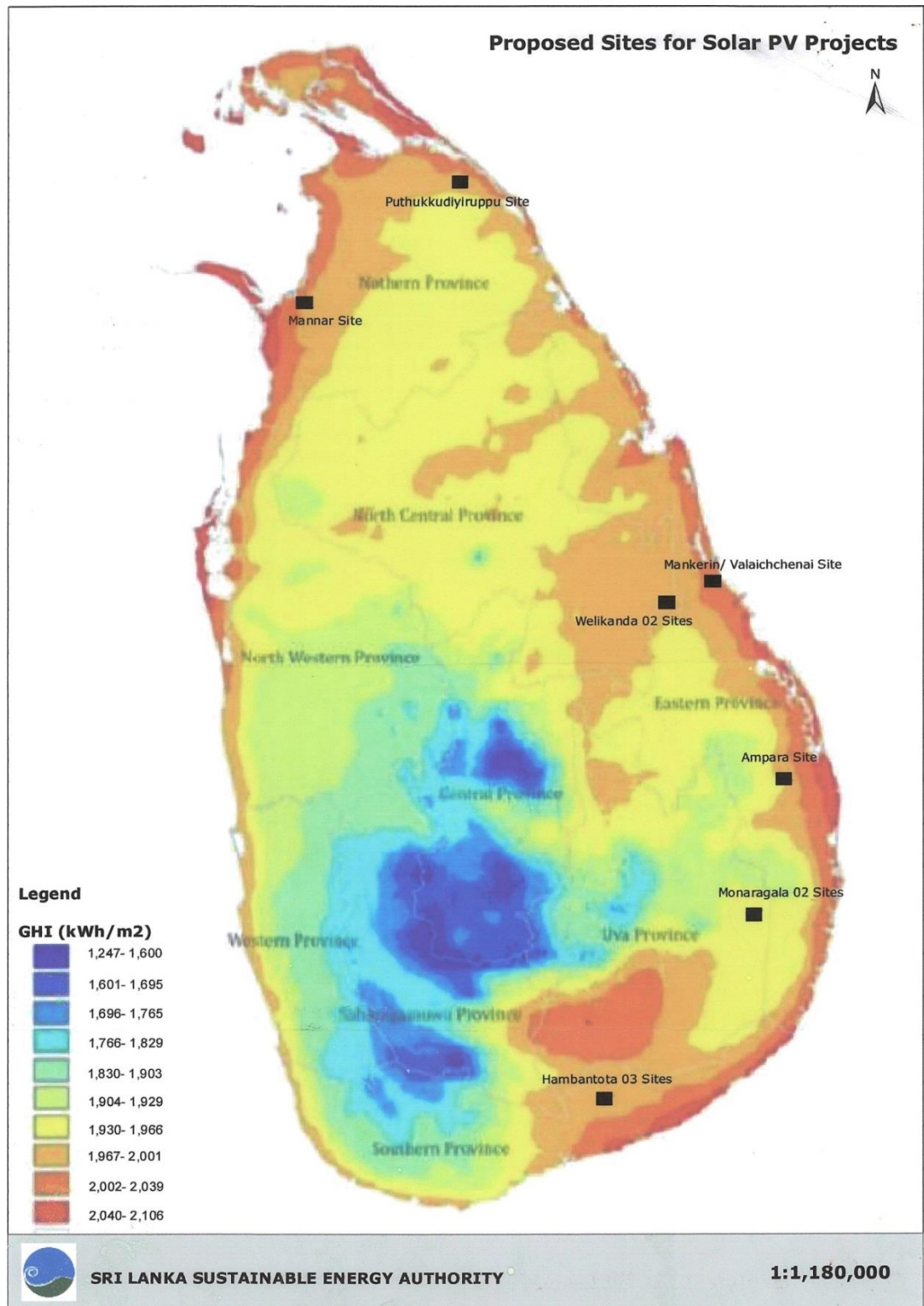

Figure 6.3: Proposed sites for solar development [25]

## 6.2 Short term frequency stability analysis

Short term frequency stability analysis has been carried out for solar power variation fixing other renewable at a defined value considered for the operational analysis. Solar plants have been modeled as 10 MW generators in PSS/E. For calculating solar power ramp rates, actual measurements taken from Hambantota 10 MW solar power plant has been considered. The highest ramp rate was used for the location where highest amount of solar generation has been fed while all the other locations were used with slow ramp rate.

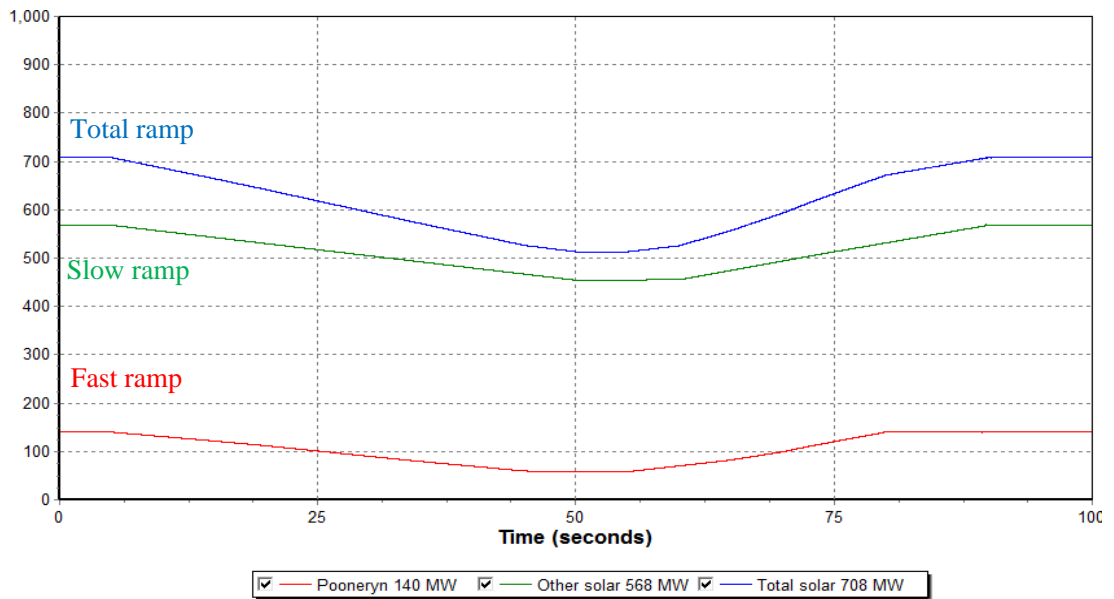

Figure 6.4: Total ramp rate variation applied to all the solar plants in year 2025

Thus, Pooneryn solar park was applied with solar fast ramping and all other remaining solar parks and 1 MW solar plants were applied with slow ramping. The total solar power variation is shown below in Figure 6.5.

The study carried out to analyze the impact of solar power ramping up and ramping down and it was changed the amount of solar PV capacity in different locations until frequency limit exceeds  $\pm 1\%$  of 50 Hz [2].

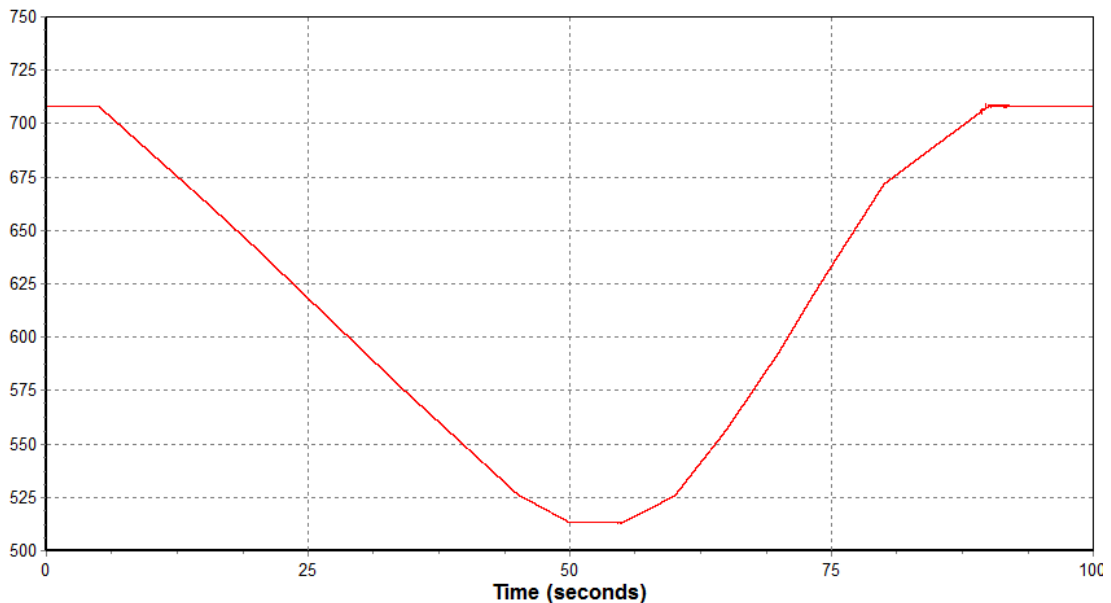

Figure 6.5: Total solar power variation

This study completely focuses on absorbing full capacity of solar proposed by the generation planning unit, hence only day peak scenarios has been considered. Among all the day peak scenarios, the study was carried out for Maximum NCRE scenario, which dispatches total 1000 MW of solar power while fully dispatching all other renewable plants. This is the worst possible scenario to study, as it gives a very small room for conventional power plants which are able to compensate the effect of intermittency and maintain the system stability.

Loading details of each grid substation is taken from the draft grid demand forecast of NCRE integration plan 2020 - 2039 of CEB – Transmission and Generation Planning Branch, for the year 2025. The study scenario includes 100% solar power which comprised of 700 MW ground mounted solar plants and 300 MW rooftop solar plants. This 300 MW has been divided among the grid substations along with the forecasted rooftop solar addition to each grid substation by year 2025. Rooftop solar is modeled as a negative load in PSS/E model and here it has been deducted from the grid loading and net grid substation load values for Maximum NCRE day peak scenario is given in Appendix C. Total net grid demand for day peak scenario is 3314 MW.



Maximum NCRE scenario is comprised of dispatching;

- Solar – 100%
- Wind – 100%
- Mini Hydro – 100%
- Dendro – 100%

This results in 1954 MW of renewable power in the system. This is 59% from the net demand of the system.

Since maximum NCRE scenario exists in the hydro maximum period, two coal units have been taken for maintenance (one each from Puttalam coal phase I and phase II). By year 2025, Sri Lankan power system has around 1600 MW of hydro power. Therefore, normal power flow case will have all NCRE plants, 3 coal de-loaded units and balanced with major hydro plants. None of the other thermal plants will be dispatched.

Table 6.7: Power plant dispatch for Max NCRE case in year 2025

<b>Energy source</b>	<b>Total capacity by 2025</b>	<b>Dispatch percentage</b>
Mini Hydro	443.6 MW	100%
Dendro	73.5 MW	100%
Wind	729.3 MW	100%
Solar	708 MW	100%
Hydro	1603.5 MW	Maximum
Coal	1375 MW	
LNG	1200 MW	
Oil	1067 MW	

The high and slow solar power ramping is applied to all 708 MW solar plants spread all around the island. According to the grid code system frequency should be maintained within  $\pm 1\%$  of 50 Hz (i.e. 49.5-50.5 Hz). Since there is ramping in solar plants, power system should have generators which have the ability to vary power output with a high rate. For this study purpose, Victoria power plant is considered as

the system swing bus. Other major hydro plants have the ability to change their power output quickly. But the combined cycle power plants have the highest rate of power output ramping up and ramping down.

### 6.1 Study part 1: Using Combined cycle power plant

As the first part of the study, it was calculated how much capacity is required to compensate the intermittency issue due to the addition of solar plants. Since the study carried out during a hydro maximum season, other than 3 coal units none of the combined cycle power plants will be dispatched. But in order to smooth out the power variability issue, LNG power plants will have to be dispatched violating the merit order. Dispatching a LNG power plant in Kerawalapitiya is more economical than when compared to Hambantota, as it's lesser in losses.

Therefore, the study was carried out for the following scenarios.

- Swing bus (Victoria) only in free governor mode
- Swing bus (Victoria) + 1 LNG machine in free governor mode
- Swing bus (Victoria) + 2 LNG machines in free governor mode

The frequency variation in each case, due to the solar power variation is shown in Figure 6.6. The results can be tabulated as follows.

Table 6.8: Minimum frequency reaches for different scenarios

Scenario	Minimum Frequency
Victoria only in free governor mode	48.75 Hz
Victoria + 1 LNG machine in free governor mode	49.25 Hz
Victoria + 2 LNG machines in free governor mode	49.5 Hz

Therefore, it can be concluded that, in order to absorb 1000 MW of solar power into Sri Lankan power network in year 2025, in a worst-case condition, at least two LNG power plants must be dispatched. But to dispatch these thermal units, same amount of hydro power plants will have to be curtailed during hydro season which is highly

uneconomical as zero cost hydro generation will be wasted (could be spilled without generating as a result) and two LNG units will have to keep on as hot spinning reserves.

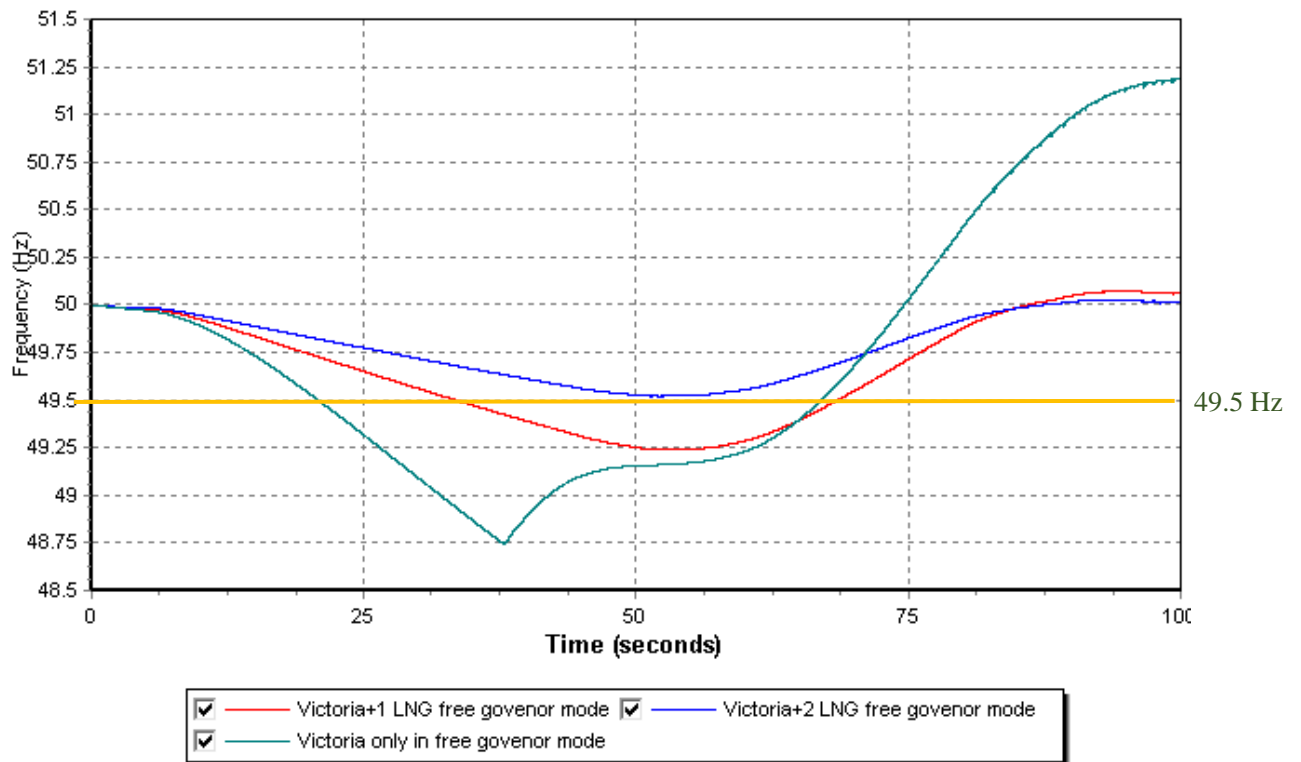

Figure 6.6: Frequency variation with LNG machines as spinning reservoirs

## 6.2 Study part 2: Using Battery Energy Storage System

The intermittency issue could be addressed using high power capacity Battery Energy Storage System (BESS). BESS is one of the most effective options to smoothen out the intermittency issue of solar power. Due to the high cost of BESS it is required to find out the optimal sizing of the required BESS.

The sizing and locating of BESS are very critical for economical perspective of the power system planning. Here the study has been carried out to calculate the minimum size of the BESS, which could keep the system frequency level within the range of 49.5 Hz – 50.5 Hz.

Initially only the sizing of the BESS is considered. For here also Victoria bus has been considered as the system swing bus and different capacities of BESS has been integrated to the system via several grid substations. Total capacity of BESS connected

has varied from 100 MW to 150 MW as shown in figure. According to that, in order to keep the frequency level above 49.5 Hz, at least 140 MW of BESS capacity is required.

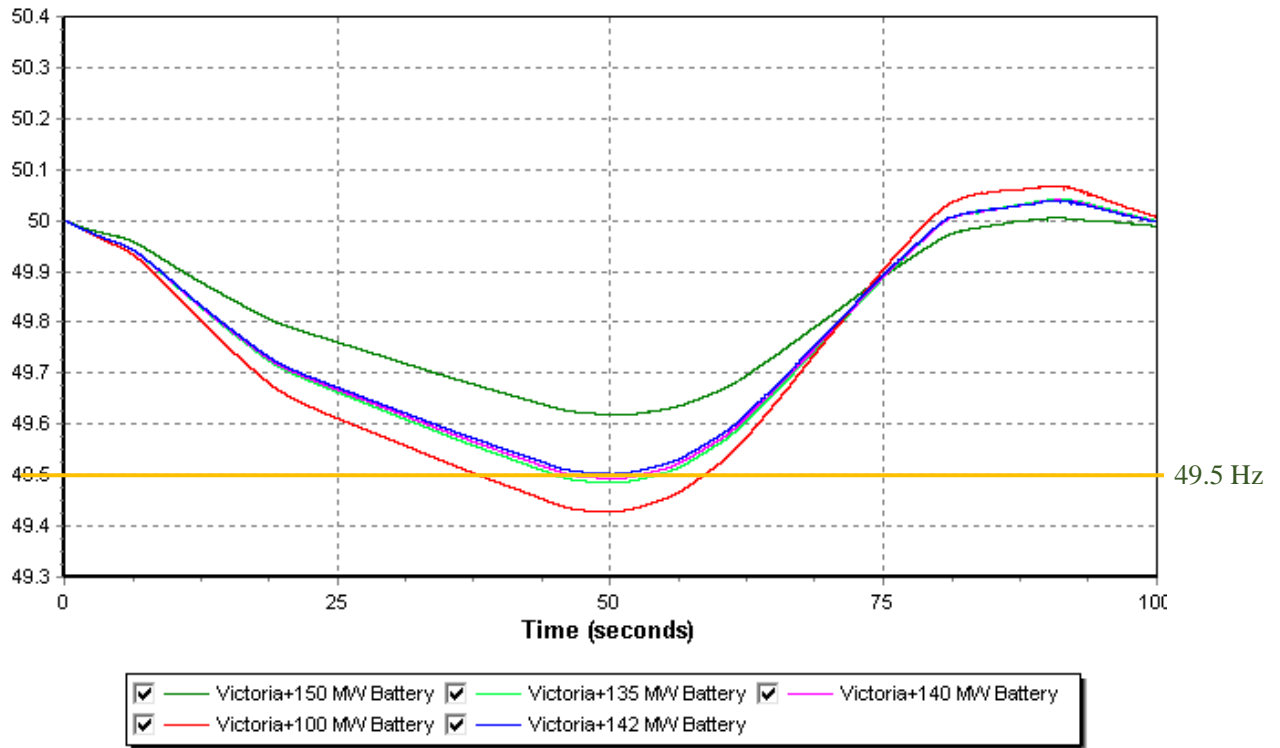

Figure 6.7: System frequency variation with different sizes of BESS

The optimal size of the BESS is calculated by changing the total BESS capacity around 140 MW. According to the above figure it can be seen that the optimal size of the BESS will be 142 MW. Due to the practicality it is concluded that the required amount of BESS capacity connected to the Sri Lankan power grid in year 2025 in order to keep the system frequency within limits is **150 MW**.

Addition of 150 MW of total BESS capacity will have further more room for possible worst cases or contingency situations. This 150 MW was comprised of three 50 MW BESSs connected to three grid substations. The active power output variation of each BESS is shown in.

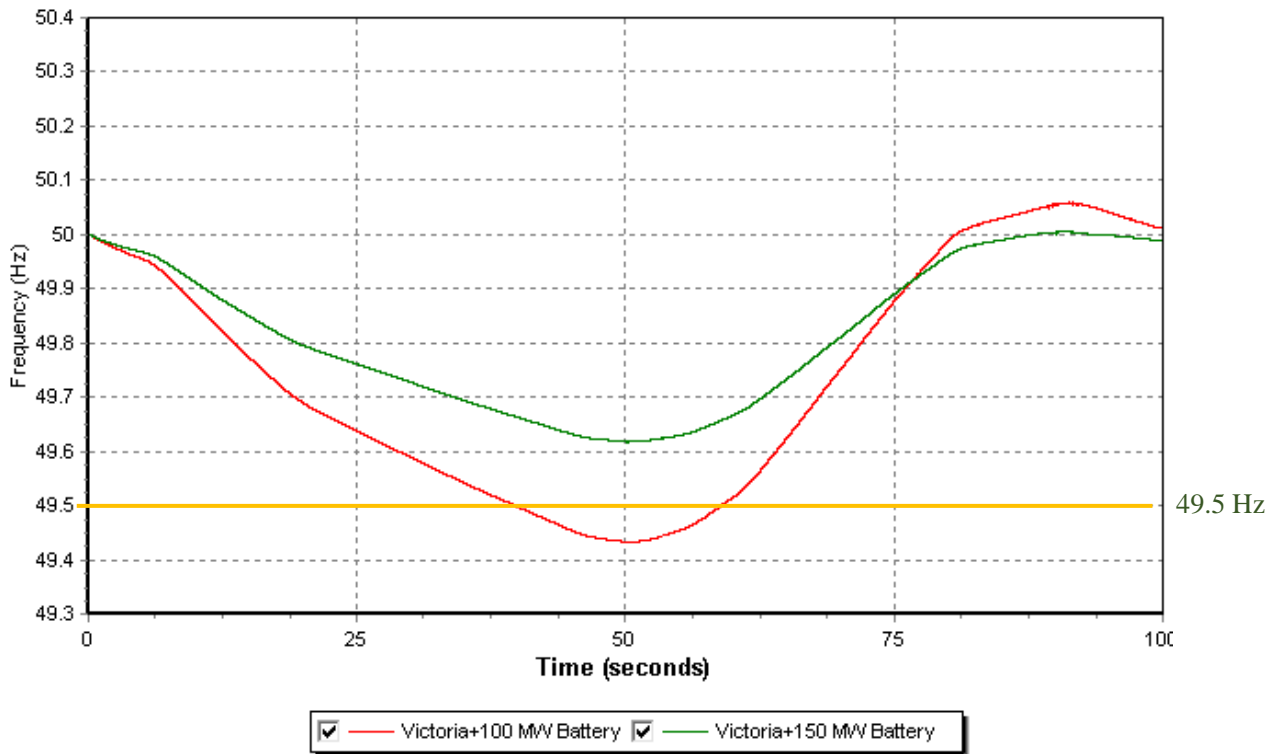

Figure 6.8: Frequency variation with 100 MW and 150 MW of BESS

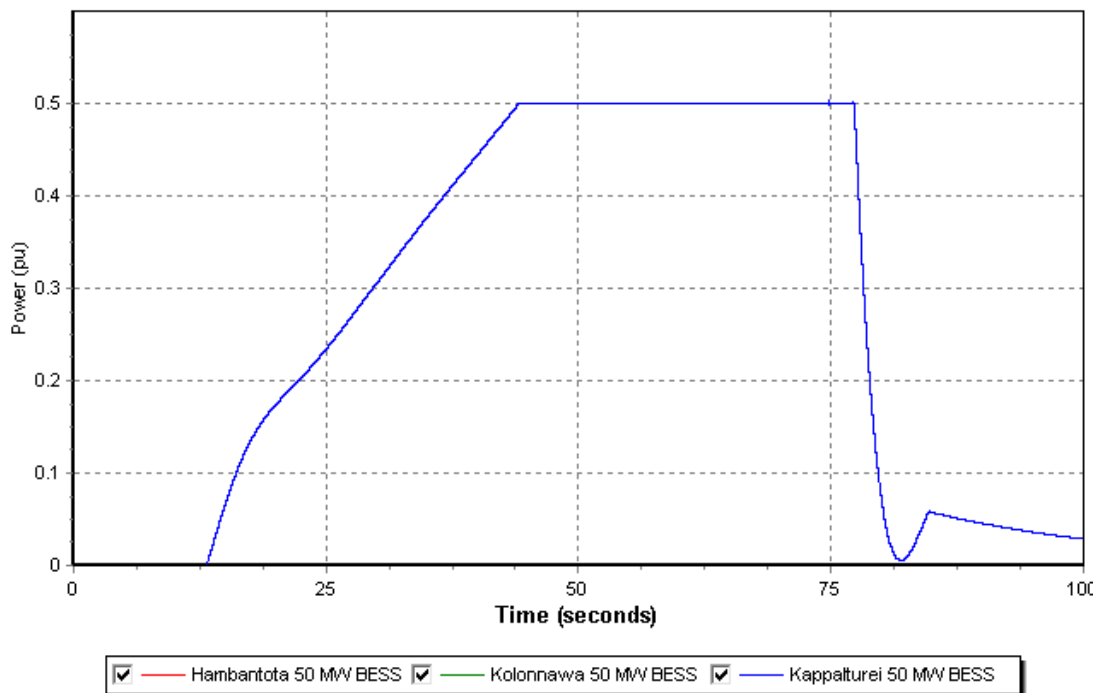

Figure 6.9: Power output of BESS

Required BESS ramp rates and other specification could be calculated and fine-tuned using these results.

As a second part optimal location for BESS is decided. The main factors affecting the locating of BESS are;

- Power loss
- Space requirement in the grid substation

Since the load flow is always towards the load center (in Sri Lanka towards Western Province), the best possible way to minimize the power loss, is to connect the BESS to grid substations in and around Western Province. But the area has a very high density of population and lacks with bare land. As a result, most of the grid substations around the city are already fully utilized. Therefore, it is required to find grid substations which have enough space to keep 50 MW of BESS.

These three 50 MW BESS will be connected to 132 kV voltage level. Therefore, as the first grid substation it is proposed Kolonnawa 132 kV grid substation which is the only grid substation in Colombo which will have sufficient space to connect 50 MW of BESS. Kolonnawa is one of the critical 132 kV grid substations as it is connected to Kelanitissa power station, Pannipitiya GSS through Sri Jayawardhanapura GSS, Kotahena GSS, Kollupitiya GSS, Maradana GSS, Athurugiriya GSS and Laxapana Complex.



Figure 6.10: Location and surrounding of Kolonnawa 132 kV GSS

Currently the grid substation is fully utilized in area wise with the newly connected emergency power units. But they will be decommissioned by year 2025 and will have space for the BESS.

The next grid substation which the 50 MW BESS could be connected is Hambantota GSS. The location has sufficient land area for expansions. This is a grid substation which has a high capacity of solar connected by year 2025. There will be 6x10MW plants and an 80 MW solar park connected. Therefore, this BESS could be used to smooth out intermittency caused by these solar output, at the grid substation itself.



Figure 6.11: Location and surrounding of Hambantota 132 kV GSS

Last 50 MW could be connected to the upcoming Kappalturei GSS. Kappalturei GSS is a 220/33 kV GSS and will be operated as 132/33 kV initially. Construction of the grid substation will be completed by mid-2020.



Figure 6.12: Location and surrounding of Kappalturei 220 kV GSS



Integrating Battery Energy Storage Systems (BESSs) into a power network always improve the system capability in terms of reliability, flexibility, strength and steadiness etc. There is no harm of adding more and more BESS to the system. Thus the limiting point is the cost of a BESS. Although the price of batteries has a trend to reduce, still the cost of a BESS is high. Therefore it is required to use the optimum capacity of BESS needed for the specified job.

This section mainly focuses on the economical aspect of utilizing BESS to smoothen out the intermittency effect caused by addition of 1000 MW of solar power by year 2025. As mentioned earlier, to keep the system frequency within the tolerable level of  $50 \pm 1\%$  according to the grid code, it is required to integrate 150 MW of BESS into the Sri Lankan network. Otherwise it is required to keep two combined cycle power plants up and running at half load, to support the power ramps of solar park. These two options have been compared financially to find out the most economical option for Sri Lanka.

There is no an exact way to evaluate financial aspects of energy supply. This task is quite complex as the sources of energy differs to each other. One major problem when comparing different types of energy technologies is to find common comparable values and variables for separate technologies. Therefore, this economical evaluation will only consider costs and not the revenues. For that the ‘Levelized Cost of Energy’ concept has been used. The Levelized Cost of Energy of combined cycle power plants could be calculated directly and for energy storages, an extended version of the concept, ‘Levelized Cost of Energy Storage’ has been used.

Basic data regarding Li-Ion BESS required to carry out the study are given in the below Table 7.1.

Table 7.1: Data of Li-ion BESS

Capacity	150 MW
Capital cost	2162 USD/kW
Operation & Maintenance Cost of BESS	2.00%
Operation & Maintenance Cost of Power Converters of BESS	0.66%
Life time	20 years

For BESS it is required to be charged. Therefore, the cost for charging should also be included. Considering the price of a single unit of electricity for the past few years, the average unit price of electricity for the year 2018 has been calculated as 18.39 LKR/kWh.

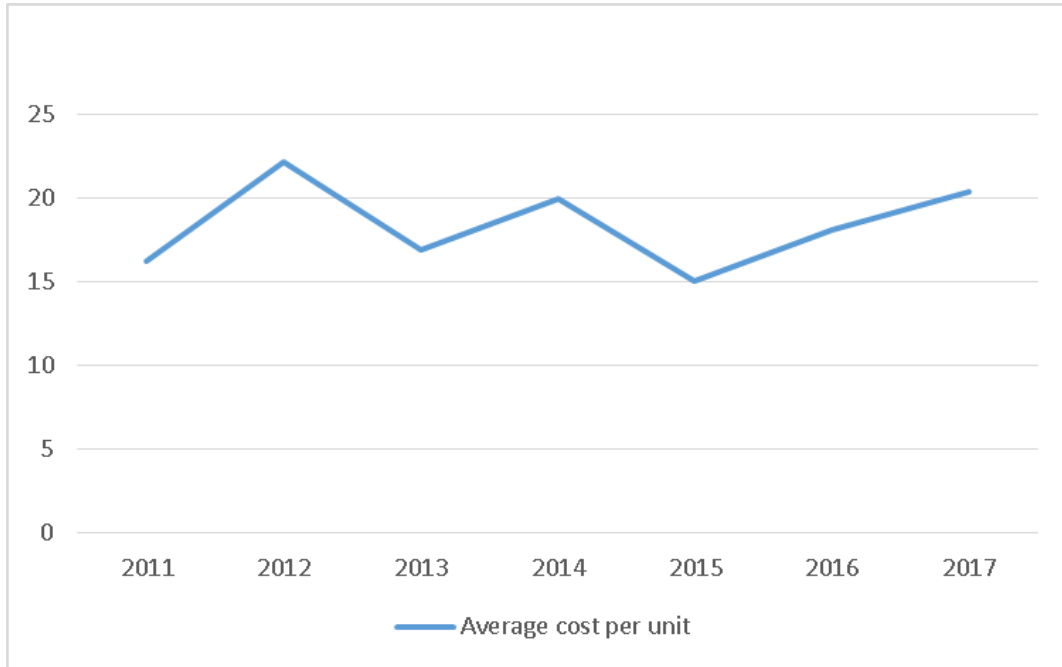

Figure 7.1: Unit price of electricity

Following parameters of three units of 50 MW BESS could be calculated from the above data.

Table 7.2: Parameters for 150MW of BESS

Capital cost	324,300,000.00	USD
O&M cost of BESS	31.18	USD/kW
O&M cost of PCS	10.2894	USD/kW
Total O&M cost	6,220,410.00	USD
Total charging cost per year	723,948.09	USD

Levelized cost of energy storage is compared with the levelized cost of energy produced by two units of combined cycle power plants operated by Liquefied Natural Gas (LNG). Basic details of a single unit of these combined cycle power plants are as below.

Table 7.3: Data of single LNG plant

Net Capacity	287	MW
Pure unit construction cost	1114.9	USD/kW
Construction period	3	Years
Interest During Construction at 10%	13.54	(% of pure capital cost)
Construction cost include of IDC	1265.9	USD/kW
Economic life	30	Years
Full load efficiency	48	%
Fixed O&M Cost	0.38	USD/kW Month
Variable O&M Cost	0.497	USCts/kWh
Scheduled maintenance days	30	days/year
Fuel Price	7.12	USCts/kWh

This results in following parameter values for the construction and operation of two combined cycle power plants.

Table 7.4: Parameters of two LNG plants

Capital cost of BESS	1,279,905,200.00	USD
Fixed O&M Cost per year	2,617,440.00	USD
Variable O&M Cost	249,742.50	USD
Total O&M Cost	2,867,182.50	USD
Total Fuel Cost for the year	85,867,200.00	USD

Since the lifetime of a BESS is 20 years, the LCOE is calculated considering the next 20 years and the interest rate is taken as 10%. It has been considered that both the BESS and LNG plants will operate 1 hour per day in order to smoothen the solar variation.

For the time period of 20 years calculation of LCOE is shown in table below;

LNG CCY plants = 3.76 USD/kWh

BESS = 0.90 USD/kWh

This shows that the BESS has a very low LCOE for 20 years' time period.

But it should be noted that total capacity of LNG power will be utilized throughout the year as firm capacity. Here it has been considered that the plant will operate only an hour per day but this is a hypothetical scenario considering only solar output power smoothing. The plant will operate at full load during day and night period in thermal maximum period and could be operated during off period in hydro maximum period for voltage stability.

When considered the LNG plant operates during day and night of thermal maximum period making the number of operating hours to 3077 h per year the LCOE of LNG plants reduced to 0.22 USD/kWh.

Table 7.5: LCOE calculation for CCY and bess

	0	1	2	3	4	5	6	7	8	9	10	19	20
<b>Combined Cycle Plants</b>													
<b>Capital</b>	853.27												
<b>Operations &amp; Maintenance</b>		2.87	2.87	2.87	2.87	2.87	2.87	2.87	2.87	2.87	2.87	2.87	2.87
<b>Fuel</b>		85.87	85.87	85.87	85.87	85.87	85.87	85.87	85.87	85.87	85.87	85.87	85.87
<b>Energy generated</b>		50250	50250	50250	50250	50250	50250	50250	50250	50250	50250	50250	50250
		1.10	1.21	1.33	1.46	1.61	1.77	1.95	2.14	2.36	2.59	6.12	6.73
	755.45	80.67	73.33	66.67	60.61	55.10	50.09	45.53	41.40	37.63	34.21	14.51	13.19
<b>PV of Annual Costs</b>	-755.45	MUSD											
<b>Investment Cost</b>	-853.27	MUSD											
<b>Total Cost</b>	-1,608.72	MUSD											
<b>Sum of Energy generated</b>	-427,806.58	MWh											
<b>LCOE</b>	<b>3.76</b>	<b>USD/kWh</b>											
<b>BESS</b>													
<b>Capital</b>	324.30												
<b>Operations &amp; Maintenance</b>		6.22	6.22	6.22	6.22	6.22	6.22	6.22	6.22	6.22	6.22	6.22	6.22
<b>Charging</b>		0.72	0.72	0.72	0.72	0.72	0.72	0.72	0.72	0.72	0.72	0.72	0.72
	59.12	6.31	5.74	5.22	4.74	4.31	3.92	3.56	3.24	2.95	2.68	1.14	1.03
<b>Energy generated</b>		50250	50250	50250	50250	50250	50250	50250	50250	50250	50250	50250	50250
<b>PV of Annual Costs</b>	-59.12	MUSD											
<b>Investment Cost</b>	-324.30	MUSD											
<b>Total Cost</b>	-383.42	MUSD											
<b>Sum of Energy generated</b>	-427,806.58	MWh											
<b>LCOE</b>	<b>0.90</b>	<b>USD/kWh</b>											

## CHAPTER 8

### CONCLUSION

---

According to the government policies it has been planned to integrate at least 20% of Non-Conventional Renewable Energy by year 2020. When compared to wind power plants, solar power plants require less capital and could be implemented within at least 6 months. Also, the environmental impact is lesser and much easier process to follow when constructing a solar plant.

But intermittent sources such as solar and wind cannot be controlled or accurately predicted. Since the energy generated from these kinds of sources are not dispatchable, it is required to use other types of controllable and dispatchable resources to balance the supply and demand of electric energy. Conventional resources must then be used to follow the net of renewable energy delivery with the electric demand and to provide essential services such as regulation and contingency reserves that ensure power system reliability. This increases the required quantity of conventional generation, and as a result additional costs may take place.

By year 2025, (according to the Least Cost Long Term Generation Expansion Plan and Long-Term Transmission Development Plan) it has been proposed to integrate 1000 MW of solar power into the Sri Lankan power system. Among this solar power 300 MW will be rooftop solar power while the remaining 700 MW will be grid connected.

It has been proposed to construct a 140 MW solar park in Pooneryn, 100 MW in Siyambalanduwa and 80 MW in Hambantota as large-scale solar plants. The Pooneryn solar park will be connected to 220 kV voltage from Northern Collector Grid Substation and both Siyambalanduwa and Hambantota solar parks will be connected to 132 kV voltage from Monaragala and Hambantota solar grid substations respectively. Another 276 MW will be connected as 1 MW plants in 33kV voltage level all over the country.

Short term frequency stability analysis has been carried out for solar power variation fixing other renewables at a defined value considered for the operational analysis.

Solar plants have been modeled as 10 MW generators in PSS/E. For calculating solar power ramp rates, actual measurements taken from Hambantota 10 MW solar power plant has been considered. The highest ramp rate was used for the location where highest amount of solar generation has been fed while all the other locations were used with slow ramp rate.

The study carried out to analyze the impact of solar power ramping up and ramping down and it was changed the amount of solar PV capacity in different locations until frequency limit exceeds  $\pm 1\%$  of 50 Hz.

The first part of the study carried out using combined cycle power plants operated using LNG. It can be concluded that, in order to absorb 1000 MW of solar power into Sri Lankan power network in year 2025, in a worst-case condition, at least two LNG power plants must be dispatched with half load. But to dispatch these thermal units, same amount of hydro power plants will have to be curtailed during high hydro season which is highly uneconomical as zero cost hydro generation will be wasted (could be spilled without generating as a result) and two LNG units will have to keep on as hot spinning reserves.

Secondly the intermittency issue has been addressed using high power capacity Battery Energy Storage System (BESS). BESS is one of the most effective options to smoothen out the intermittency issue of solar power. In order to keep the frequency level above 49.5 Hz, at least 140 MW of BESS capacity is required. The optimal size of the BESS is calculated by changing the total BESS capacity around 140 MW and the optimal size of the BESS was 142 MW. Due to the practicality it is concluded that the required amount of BESS capacity connected to the Sri Lankan power grid in year 2025 in order to keep the system frequency within limits is **150 MW**.

Addition of 150 MW of total BESS capacity will have further more room for possible worst cases or contingency situations. This 150 MW was comprised of three 50 MW BESSs connected to three grid substations. The main factors affecting the location of BESS are power loss and space requirement in the grid substation. By considering these factors Kolonnawa, Hambantota and Kappalturei grid substations has been selected for the installation of 50 MW BESS.

## CHAPTER 9

### REFERENCES

---

- [1] "Least Cost Long Term Generation Plan 2018 - 2037," Ceylon Electricity Board, Colombo, 2018.
- [2] "Draft Grid Code," Transmission Division, Ceylon Electricity Board, Colombo, 2018.
- [3] "Integration of renewable based generation into Sri Lankan Grid 2017-2028," Ceylon Electricity Board, Colombo 02, 2016.
- [4] "Long Term Generation Expansion Plan," Ceylon Electricity Board, Colombo 02, 2018 June.
- [5] J. Marcos, O. Storkel, L. Marroyo, M. Garcia and E. Lorenzo, "Storage requirement for PV power ramp-rate control," Associate Editor Elias Stefanakos, Spain, 2013.
- [6] X. Wang and M. Yue, "Design of Energy Storage System to Improve Inertial Response for Large Scale PV Generation," IEEE, New York, 2016.
- [7] DOE/EPRI Electricity Storage Handbook in Collaboration with NRECA, United States: National Nuclear Security Administration, 2015.
- [8] "Electricity Storage and Renewables: Costs and Markets to 2030," The International Renewable Energy Agency, Abu Dhabi, 2017.
- [9] D. Bazargan, "A Study of Battery Energy Storage Dynamics in Power System," University of Manitoba, Manitoba, 2017.
- [10] X. Wang and M. Yue, "Design of Energy Storage System to Improve Inertial," IEEE, New York, 2016.

- [11] "Battery Storage for Renewables: Market status and technology outlook," The International Renewable Energy Agency, Abu Dhabi, 2015.
- [12] I. Pawel, "The cost of storage - how to calculate the levelized cost of stored energy and applications to renewable energy generation," in *8th International Renewable Energy Storage Conference and Exhibition*, 2013.
- [13] "Power System Model Validation," North American Electric Reliability Corporation, Princeton, 2010.
- [14] "Approaches to Validation of Power System Models for System Planning Studies," Pouyan Pourbeik, IEEE.
- [15] "PSS/E 33.5 Model Library," Siemens Power Technology International, New York, 2013.
- [16] "Solar PV Plant Model Validation for Grid Integration Studies," Sachin Soni, Arizona, 2014.
- [17] "WECC Guide for Representation of Photovoltaic Systems In Large Scale Load Flow Simulations," WECC Renewable Energy Modelling Task Force, Utah, 2010.
- [18] "WECC Guideline: Central Station Photovoltaic Power Plant Model Validation Guideline," WECC Renewable Energy Modeling Task Force, Utah, 2015.
- [19] M. Alam, K. Muttaqi and D. Sutanto, "A Novel Approach for Ramp-Rate Control of Solar PV Using Energy Storage to Mitigate Output Fluctuations Caused by Cloud Passing," in *IEEE Transaction on energy conversion*, 2014.
- [20] "Evaluate and Design Battery Support Services for the Electric Grid," Brian de Beer, Stellenbosch, 2017.
- [21] "Grid Frequency Stability Analysis of Variable Renewable Energy in the CEB System," Siemens PTI, New York, 2017.



- [22] P. Kundur, Power System Stability and Control, New Delhi: Tata McGraw-Hill, 2008.
- [23] D. Cicio, "EssPro - Battery energy storage," ABB, Peru, 2017.
- [24] "WECC Battery Storage Dynamic Modeling Guideline," WECC Renewable Energy Modeling Task Force, Utah, 2016.
- [25] "Sri Lanka Sustainable Energy Authority," [Online]. Available: <http://www.energy.gov.lk/en/>. [Accessed 12 August 2018].

System data prior to the event which were collected from the National System Control Centre is given below.

<b>GENERATION</b>	
<b>Date</b>	<b>: 07.11.2017</b>
<b>Time</b>	<b>: 01:54 am</b>
	<b><u>MW</u></b>
<b><u>MAHAWELI COMPLEX</u></b>	
Victoria 01	55
Victoria 02	50
Kotmale 01	30
Kotmale 02	30
Ukuwela 02	20
<b><i>TOTAL (mahaweli)</i></b>	<b><i>185</i></b>
<b><u>LAXAPANA COMPLEX</u></b>	
New Laxapana 01	10
New Laxapana 02	10
Polpitiya 01	12.7
Polpitiya 02	31.6
Old Laxapana 01	9.6
Old Laxapana 02	9.6
Old Laxapana 03	9.6
Old Laxapana 04	10
Old Laxapana 05	12.5
Wimalasurendra 02	25
<b><i>TOTAL (laxapana)</i></b>	<b><i>140.6</i></b>
<b><u>CEB COAL</u></b>	
Puttalam Coal01	200
Puttalam Coal02	0
Puttalam Coal03	197
<b><i>TOTAL (CEB Coal)</i></b>	<b><i>397</i></b>
<b><u>OTHER HYDRO</u></b>	
Kukule 01	37.5
Kukule 02	37.5
<b><i>TOTAL (Kukule)</i></b>	<b><i>75</i></b>

<b><u>PRIVATE POWER</u></b>	
West Coast GT1	76
West Coast GT2	39.3
<b><i>TOTAL (PPP)</i></b>	<b><i>115.3</i></b>
<b><u>RENEWABLE</u></b>	
<i>Norechcole Wind</i>	3.4
<i>Seguwanthive / Vidathamuni</i>	1
<i>Musalpiti wind</i>	1.1
<b><i>TOTAL (RENEWABLE)</i></b>	<b><i>5.5</i></b>
<b><i>GRAND TOTAL(MW)</i></b>	<b><i>918.4</i></b>

Grid Substation loadings are as follows.

		<b>MW</b>	<b>Mvar</b>
WIMAL-3	33.000	-15	0
AMPA-3	33.000	3	0
INGIN-3	33.000	0	0
UKUWE-3	33.000	3.3	1.598263
VAVUN-33	33.000	11.9	1.2
RANTE-3	33.000	0.17	0.03452
MAHIYANGANA	33	2	0
KELAN-3A	33.000	13.45	6.514132
KELAN-3B	33.000	0	0
NAULA		2	0
MONARA		4	0
BELIATT-3	33	7.2	1
HAMBA-33	33.000	7.7	1.8
HAMBA-33	33.000	4.8	1.8
HORANA_3	33.000	33	15.98263
KATUNA-3	33.000	28	10.6
MAHO-3	33.000	8	0

POLON-3		6.2	1.4
VAUNA -3		5.658537	1.859871
PALLEK-3		9.885714	0
KOSGA-3	33.000	22.4	8
SITHA-33	33.000	0	0
NUWAR-3	33.000	3	0.986052
THULH-3	33.000	25	8.578655
ORUWA-3	33.000	0	0
KOLON-3A	33.000	22	7.888419
KOLON-3B	33.000	15	4.930262
PANNI-3	33.000	10	65.6
BIYAG-3	33.000	30	21
BIYA_33	33.000	0	0
KOTUG-3	33.000	10.6	5.484052
KOTUG_NEW-3	33.0	26.3	9.005944
SAPUG-3A	33.000	31	14.92226
BOLAW-3	33.000	29	17.64959
BADUL-3	33.000	12	0
BALAN-3	33.000	-0.9	-2.1
DENIY-3	33.000	7.2	1.462022
GALLE-3	33.000	0	0
NEW_GALLE	33.000	27.9	9.170287
EMBIL-3	33.000	8	0
MATARA-3	33.000	39	6.9
KURUN-3	33.000	9	0
HABAR-3	33.000	18	2.4
ANURA-3A	33.000	11.52857	2.340976
ANURA-3B	33.000	2.5	0.507647
NEWANU-3	33.000	10	1
TRINC-3	33.000	25.8	5.238913

KILINCHCHI 33.00	-6.9	-3.9
CHUNNAKAM 33.00	2	1.16
RATNAP-3 33.000	0	6
KIRIB-3 33.000	24	9.485407
VALACH_3 33.000	6	2
VALAC3 33.000	0	0
RATMA-3A 33.000	32.4	9.9
MATUG-3 33.000	25.8	6.6
PUTTA-3 33.000	9	0
CEMENT 33.000	15	9
ATURU-3 33.000	23	6.708333
VEYAN-33 33.000	29	8.458333
JPURA_3 33.000	24.5	11.4
PANAD-3 33.000	32.4	9.45
MADAM-3 33.000	25	18
K-NIYA-3 33.000	24	8.151366
AMBALA 33.000	17.6	5
DEHIW_3 33.000	18.4	8.4
PANNAL 33.000	21	6.6
ANIYA 33.000	22	10
COL_I_11 11.000	13.1	4.08
COL_A_11 11.000	17.3	4.6
COL_E-11 11.000	18.1	4
COL_F-11 11.000	15.94	6.73
PUT COAL AUX	0	0
PUT COAL AUX	0	0
PUT COAL AUX	0	0
COL_C-11 11.000	11.1	4.1