

**ANALYSIS OF COOLING TOWER PERFORMANCE OF
WORLD TRADE CENTER IN COLOMBO**

W. A. D. P. Wickramasinghe

(2015-148633T)

Degree of Master of Science

Department of Mechanical Engineering

University of Moratuwa

Sri Lanka

January 2019

ANALYSIS OF COOLING TOWER PERFORMANCE OF WORLD TRADE CENTER IN COLOMBO

W. A. D. P. Wickramasinghe

(2015-148633T)

Thesis submitted in partial fulfillment of the requirement for the degree
Master of Science in Building Services Engineering

Department of Mechanical Engineering

University of Moratuwa

Sri Lanka

January 2019

Declaration

I declare that this is my own work and this thesis does not incorporate without acknowledgement any material previously submitted for a Degree or Diploma in any other University or institute of higher learning and to the best of my knowledge and belief it does not contain any material previously published or written by another person except where the acknowledgement is made in the text.

Also, I hereby grant to University of Moratuwa the non-exclusive right to reproduce and distribute my thesis, in whole or in part in print, electronic or other medium. I retain the right to use this content in whole or part in future works (such as articles or books).

.....

W. A. D. P. Wickramasinghe

The above candidate has carried out research for the thesis under my supervision.

.....

Prof. K. K. C. K. Perera

The above candidate has carried out research for the thesis under my supervision.

.....

Dr. (Mrs) M. M. I. D. Manthilaka

Abstract

Energy crisis first experienced in the world during 1975, since then it is ever rising phenomenon felt by every human being on earth. This is due to accelerated industrialization of the world and rapid growth of standard of living of people. Therefore, global Energy requirement is increased day by day deficit between energy available is increasing. It is felt that energy preservation is much more important than searching for New Sources. Sustainability has been introduced to building services to reduce waste of energy and provide for future. Green building concept is increasingly popular in terms of reducing fossil fuel usage and introducing alternative energy utilization. Reducing Carbon foot print of a building is the responsibility of the engineer in modern times to support the sustainability goals. Heating, Ventilating & Air conditioning (HVAC) systems in Commercial buildings accounts for 60% to 70% of their total power consumption. This thesis explores the possibilities of improving the configuration of cooling tower and optimization of the chiller plant.

A central chiller plant for tall-building was analyzed for the effect of improving efficiency to enhance energy saving with varying cooling tower combinations and fan speed regulation. It was revealed that increasing the combination of cooling towers has a limitation of efficiency rise. However, reducing fan speed with increasing chiller combination prove to be success in the increasing efficiency of the chiller plant.

Acknowledgement

It is my sincere gratitude to my principal supervisor Prof. K. K. C. K. Perera & Co-supervisor Dr. (Mrs) Inoka Manthilaka for his continuous & very sincere tireless expertise guidance and direction throughout this research project. I am very much thankful to all the lecturers who gave me wealth of knowledge during the course of Building Services Engineering. Also I am thankful to Eng. Chandana Dalugoda, HVAC Consultant who gave me technical information and guided me to complete the Thesis successfully. Further I am very much thankful to Eng. Prasanna Narangoda, Eng. Sampath Godamunna, Eng. Jeewaka Samarasekara and Maintenance staff of World Trade Centre (WTC), who provided valuable support in data acquisition during this research project.

I would like to express my sincere thanks to my colleagues who generously share their knowledge and experiences with me.

Finally, I am very much thankful to my family for their encouragement, support plus patience during the period of my work for this research project.

Contents

Declaration	i
Abstract	ii
Acknowledgement.....	iii
Contents	iv
List of Figures	vii
List of Tables.....	viii
List of Charts.....	ix
List of Abbreviations.....	x
Chapter-1.....	1
1.Introduction.....	1
1.1. Background	1
1.1.1. History of Air Conditioning.....	1
1.1.2. Thermal Comfort	1
1.1.3. Air Conditioning Applications.....	1
1.1.4. Basic Air Conditioning System	2
1.1.5. Design strategies for efficient central air conditioning system.....	3
1.1.6. Ways and means of improving the Energy Efficiency	3
1.2. Context	6
1.3. Problem Statement / Research Gap.....	8
1.4. Aim.....	8
1.5. Objectives.....	9
1.6. Methodology	9
1.7. Work Flow Chart.....	10
Chapter-2.....	11
2. Literature Review.....	11
2.1. All-Water Air Conditioning System	11
2.2. Major Items of Central Air-Conditioning System.....	12
2.2.1. Chiller	12
2.2.2. Air handling unit.....	13
2.2.3. Fan coil unit	14
2.2.4. Heat Rejection Equipment	15
2.3. Cooling Tower.....	16

2.3.1. Cooling Tower Design Consideration	18
2.3.2. The cooling tower Categorization.....	19
2.3.2.1.Open type towers	19
2.3.3. Classification of Cooling Tower	20
2.3.3.1.Classification by build	20
2.3.3.2.Classification based on heat transfer method	21
2.3.3.3.Classification based on air draft	21
2.3.4. Components of a Cooling Tower	24
2.3.4.1.Structural Components	24
2.3.4.2.Mechanical Components	26
2.3.4.3.Electrical Components.....	27
2.3.4.4.Tower materials	28
2.3.5. Operation Considerations	29
2.3.6. Tower Problems	30
2.3.7. Maintenance and Water Quality	31
2.3.8. Water Loop Enhancements.....	32
2.3.9. Tower Performance	34
2.3.10.Measuring Performance	35
2.3.11.Measuring Parameters	36
2.3.12.Right Selection of Cooling Tower	38
2.3.13.Improving Energy Efficiency of Cooling Towers	41
2.3.14.Governing factors of operation of cooling tower	42
2.3.15.Achieving Energy Efficiency	43
2.3.16.Water vs. Air Cooled Systems	44
2.3.17.Cooling tower ratings	44
Chapter-3.....	47
3. Data Collection & Analysis	47
3.1. Data Collection.....	47
3.1.1. Design for Data collection	47
3.1.2. Limitations	53
3.1.3. Considerations	53
3.1.4. Details of Plant and Machinery used for Data Collection	53
3.1.5. Data Collection (WTC) – Stage 1	55

3.1.5.1.Calculation	57
3.1.5.1.1.Cooling Load Calculation of Chiller	57
3.1.5.1.2.Power Consumption of Chiller.....	57
3.1.5.1.3.Three phase power calculation (VFD driven)	57
3.1.5.1.4.Calculated Figures	61
3.1.5.2.Analysis	62
3.1.5.3.Mathematical Analysis	65
3.1.5.4.Observation of Stage 1:	67
3.1.6. Data Collection (WTC) – Stage 2.....	68
3.1.6.1.Calculation	70
3.1.6.2.Analysis	73
3.1.6.3.Mathematical Analysis	76
3.1.6.4.Observation of Stage 2:	78
Chapter-4.....	79
4. Conclusions and Recommendations	79
4.1. Conclusions	79
4.2. Recommendations	80
Chapter-5.....	82
5.Reference.....	82

List of Figures

Figure 1 : Vapor compression cycle on P-Chart	4
Figure 2 : Chiller Plant	5
Figure 3 : Benefits of a variable frequency drive	7
Figure 4 : Configuration of water cooled chiller plant	11
Figure 5 : Chiller Plant	12
Figure 6 : Air handling unit	13
Figure 7 : Fan coil unit	14
Figure 8 : Cooling Tower	16
Figure 9 :Cooling tower schematic diagram	18
Figure 10 : Open type cooling towers	19
Figure 11 : Natural draught tower	21
Figure 12 : Natural draught hyperbolic tower.....	22
Figure 13 : Induced draft	23
Figure 14 : Cross flow tower	23
Figure 15 : Forced draft	24
Figure 16 : Typical performance curve, Single cell tower with single speed motor	33
Figure 17 : Typical performance curve. Three cell tower with single speed motors	33
Figure 18 : Typical performance curve. Three-cell tower with two speed motor	33
Figure 19 : Common header systems	36
Figure 20 : Range and Approach	37
Figure 21 : For refrigerating machines in HVAC systems, reducing the condensing temperature leads to lower energy consumption	43
Figure 22 : PID control loop	80

List of Tables

Table 1: Comparison of Cooling Tower Fill Types	40
Table 2: Tower Data in US Condition	44
Table 3: Tower Data in Local Condition	45
Table 4 : Colombo Three Hourly Wet Bulb Temperature - 2018.....	48
Table 5 : Plant and Equipment	53
Table 6 : Cooling Tower Data.....	55
Table 7 : Chiller Data.....	56
Table 8 : Cooling Tower Data & Calculations	58
Table 9 : Chiller Data & Calculations.....	59
Table 10 :Calculated Figures	61
Table 11 : Cooling tower combination Vs Approach	62
Table 12 : Cooling tower combination Vs Total power consumed by CTs/kW	63
Table 13 : CT combination Vs COP	64
Table 14 : Comparison of the cost electrical power of each combination	65
Table 15 : Cooling Tower Data.....	68
Table 16 : Chiller Data.....	69
Table 17 : Cooling Tower Data & Calculations.....	70
Table 18 : Chiller Data & Calculations.....	71
Table 19 : Cooling tower fan speed Vs Approach (T CT(Lea - Wet))	73
Table 20 : Cooling tower fan speed Vs Total Power Consumed by CTs /kw	74
Table 21 : Cooling tower fan speed	75
Table 22 : comparison of the cost of electrical power of each fan speed	76

List of Charts

Chart 1 : Wet Bulb Temperature in Colombo Area	50
Chart 2 : WBT in colombo & proposed leaving water temperature with best CT	52
Chart 3 : Approach (With site WB)	62
Chart 4 : Total power consumed by CTs/kW.....	63
Chart 5 : COP.....	64
Chart 6 : Operational Cost of Cooling Towers & Chillers in Rupees.....	65
Chart 7 : Approach (T CT(Lea - Wet))	73
Chart 8 : Total Power Consumed by CTs /kW	74
Chart 9 : COP.....	75
Chart 10 : Cost of Power Rs./kWhr	76

List of Abbreviations

Abbreviations	Description
AHRI	Air-Conditioning, Heating, and Refrigeration Institute
AHU	Air Handling Unit
ASHRAE	American Society of Heating, Refrigerating and Air-Conditioning Engineers
BMS	Building Management System
CAV	Constant Air Volume
CHW	Chilled Water
CIBSE	Chartered Institution of Building Services Engineers
CPM	Chiller Plant Manager
CT	Cooling Tower
CTI	Cooling Technology Institute
CW	Condenser Water
DOAS	Dedicated Outdoor Air System
DX	Direct Expansion
FCU	Fan Coil Unit
IT	Information Technology
MAU	Makeup Air Unit
PMV	Predicted Mean Vote
US	United State
VAV	Variable Air Volume
VRV	Variable Refrigerant Volume
VSD	Variable Speed Drives
WTC	World Trade Center

Chapter-1

Introduction

Energy absorbed by the refrigeration system with heat of compression is dissipated at the air-cooled condenser or at the cooling tower. It is obvious that the efficiency of the heat rejecting equipment has a major role in achieving overall energy efficiency of the air conditioning plant. In this study, energy efficiency of central chiller system is analyzed in depth to find the best optimum cooling towers configuration.

1.1. Background

1.1.1. History of Air Conditioning

Mr. Willies H. Carrier invented the air conditioning machine in 1902, to solve a problem in lithography printing plant at the Sackett & Wilhelms in Brooklyn, New York. Since then he went on cratering the Carrier Corporation, which introduced, first room air conditioner, first centrifugal refrigeration machine, first air conditioning for high-rise building etc.

1.1.2. Thermal Comfort

Thermal comfort is in our mind in relation to thermal environment. There are two factors affecting thermal comfort; Environmental factors & Personal factors. Environmental factors are air temperature, mean radiant temperature, humidity, and relative air speed. Physical factors are metabolic heat production & Clothing. Thermal comfort is found using Predicted Mean Vote (PMV) suggested by ASHRAE Standard 55. Accepted thermal comfort conditions are PMV +0.5 to -0.5.

1.1.3. Air Conditioning Applications

Air conditioning Applications can be categorized as Comfort air conditioning and Process cooling applications. Comfort cooling applications primary function is to provide human comfort environment. Examples of human comfort applications are offices, shops, lecture rooms, auditoriums, factories etc. Process cooling

applications are IT cooling or server room applications, Cleanrooms such as hospital operating theaters (ISO Class 100,000), Micro chip manufacturing factories (ISO Class 1000).

1.1.4. Basic Air Conditioning System

Basic air conditioning systems falls into four categories, (1) All-Air System, (2) Air-Water system, (3) All-Water system & (4) Unitary Systems. All air systems comprise of Single duct systems & Dual duct systems. All-Air systems provide the entire sensible and latent cooling capacity through the cold air supplied to the conditioned space. No additional cooling is required at the zone. All air systems usually utilize Roof Top units with central ductwork and air-side system could be either constant air volume (CAV) or Variable air volume (VAV).

Air & Water systems conditions the space by distributing air & water sources to terminal units (induction units) installed in the space. The air & water are cooled or heated in a central mechanical equipment room. The air supplied is primary air & the water supplied is secondary water. Primary air is sent from a central AHU via high pressure ductwork, absorbs the moisture in the space and the secondary water cools a cooling coil kept above room dew point, which absorbs only sensible heat. The secondary air from room induced through the cooling coil absorbs sensible load.

All-water systems is one which the space cooling functions performed by chilled water circulated from central refrigeration plant to terminal units or fan coil units (FCU) in the conditioned space. Modern air conditioning systems are usually All-Water systems, where water-side system shall be either 4-pipe or 2-pipe system utilizing FCUs with central treated fresh air and extract ductwork. FCUs are usually ceiling concealed type and flexible or ridged ductwork connects to linear slot diffusers or square ceiling diffusers. Fresh air and extract ducts are terminated inside the ceiling.

Unitary Equipment Systems are utilizing unitary air conditioning equipment which are assembly of factory-matched refrigerant cycle components for inclusion

in field designed air conditioning systems. The unitary equipment are window type units, residential type DX-Split units or Variable Refrigerant Volume (VRV) units.

1.1.5. Design strategies for efficient central air conditioning system

- a. Comply Energy Standard for Buildings ASHRAE 90.1 for Chiller Part Load and Full Load Efficiency minimum values
- b. Testing and Commission of the A/C System complying with ASHRAE/CIBSE Commissioning codes
- c. Proper selection of Cooling Towers
- d. Design of appropriate CHW piping system
 - I. Variable primary CHW system
 - II. Constant primary, Variable Secondary de-coupled CHW system
- e. Integrate Chiller Controls with BMS

1.1.6. Ways and means of improving the Energy Efficiency

- i. Selection of high efficiency chillers such as tri-rotor screw compressor chillers or magnetic bearing oil free compressor centrifugal chillers in the range of ≥ 10 COP IPLV.
- ii. Selection of cooling towers to complying with ASHRAE 90.1, minimum power requirement.
- iii. Introduce either primary variable CHW system or Primary constant, secondary variable de-coupled CHW system utilizing 2-way control valve.
- iv. Select the cooling towers at AHRI conditions, CTI certified towers for energy efficiency.
- v. All ways select water-cooled chillers, unless otherwise required for sites with water scarcity, instead of air-cooled to achieve higher efficiency and reduced power consumption.
- vi. Apply CHW reset to reduce compressor power during part load condition via BMS OR CPM.
- vii. Optimizing the chiller performance after 2-3 years operation, utilizing chiller plant manager (CPM) or BMS.

The conventional energy audits provide energy recommendations focusing on the energy use of cooling towers for point of use energy, in terms of pumping savings and variable speed fans. The actual energy usage of a cooling tower is trivial and represents a minute portion of the total energy requirement of the cooling system. The majority of energy being used to absorb heat at lower temperature and release to atmosphere at higher temperature. Whereas, the heat absorbed to conduct refrigeration against the input power is commonly defined as the coefficient of performance.

Vapor compression cycle on P-Chart

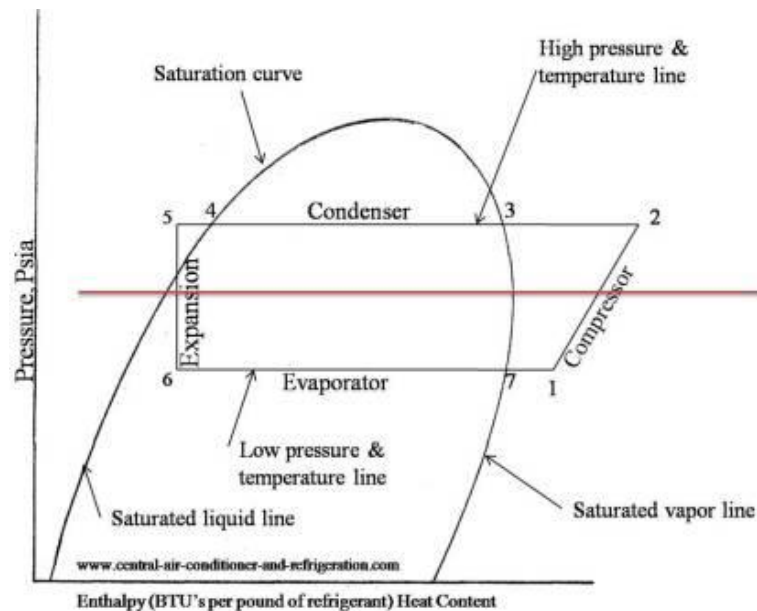

Figure 1 : Vapor compression cycle on P-Chart [1]

Effect of higher condensing Temperature

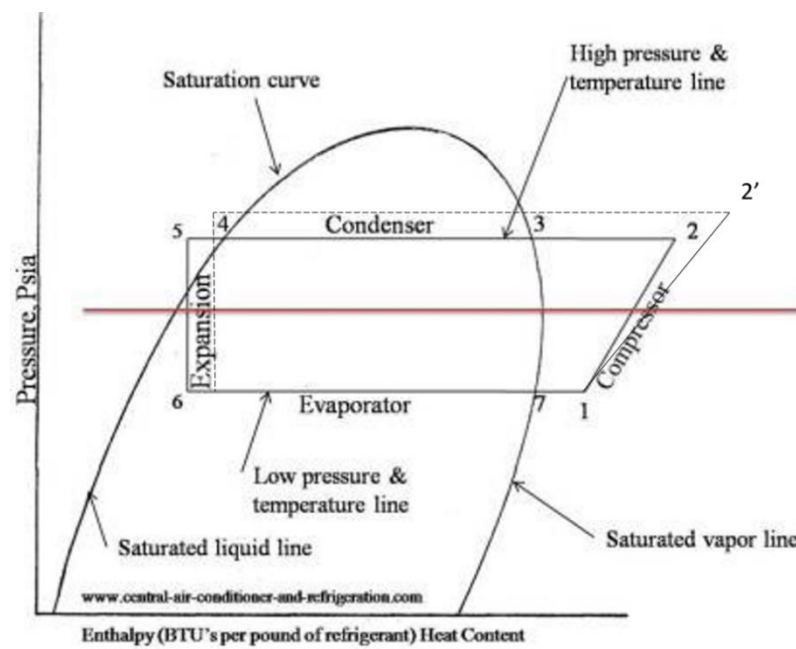

Figure 2 : Chiller Plant [1]

1. Increased compressor work done
2. Possible overloading the compressor driver
3. Reduction of refrigerating effect
4. High delivery temperatures
5. Increased compression ratio

The original conditions for design and type of tower such as evaporative or draft driven etc. impact the efficiency of a tower. Inefficiencies could arise as a result of flawed operational strategies, under or over sizing, improperly functioning controls and insufficient basic maintenance that could result fouling of the exchangers.

This paper intends to investigate the efficiency relationship between the chiller and the tower, with the emphasis on developing a methodology to measure and estimate the efficiency within a limited time frame of one to two-day assessment. Current advanced inexpensive devices allow the measurement and

monitoring of process cooling temperatures, humidity, temperature of air and sump temperature within a limited time period. Particularly, such devices could be installed swiftly by plant personnel and placed for a period of week or more and could be returned to the auditor via mail with the collected data.

This paper is comprised of information on how to determine the suitable design conditions for towers, its temporal performance along with tips from main tower manufacturers on design, performance and maintenance.

1.2. Context

- Most of the Cooling Tower / water-cooled condenser of chillers are operated in a mismatch situation in Sri Lanka which has led to energy waste and increased utility costs.
- Cooling tower energy consumption is not taken into consideration when they are operated 24 hour conditions.
- Cooling tower makeup water requirement usually a considerable cost, which is not mitigated by the designers.
- Most of the time wet bulb temperature in Sri Lanka is higher than the design temperature. Therefore, even we use smallest approach level cooling tower, it's not possible to get better performance of chillers.
- Even though, the wet bulb temperature is higher than design condition. Our aim to find the way to get Lower Leaving Water temperature at CT.
- Most of the commercial and government high rise buildings are air conditioned by using water cool multiple chiller system.
- Always one stand by chiller is sleeping with one cooling tower on the rooftop.
- Operators may not have an idea to use idle cooling tower to reduce the condenser water temperature or they may think it's not economical.
- Our data collection is targeted to prove, the usage of idling cooling towers with variable speed drive is economical. Running of VFDs in low frequency levels is reduced the power consumption.

Benefits of a variable frequency drive

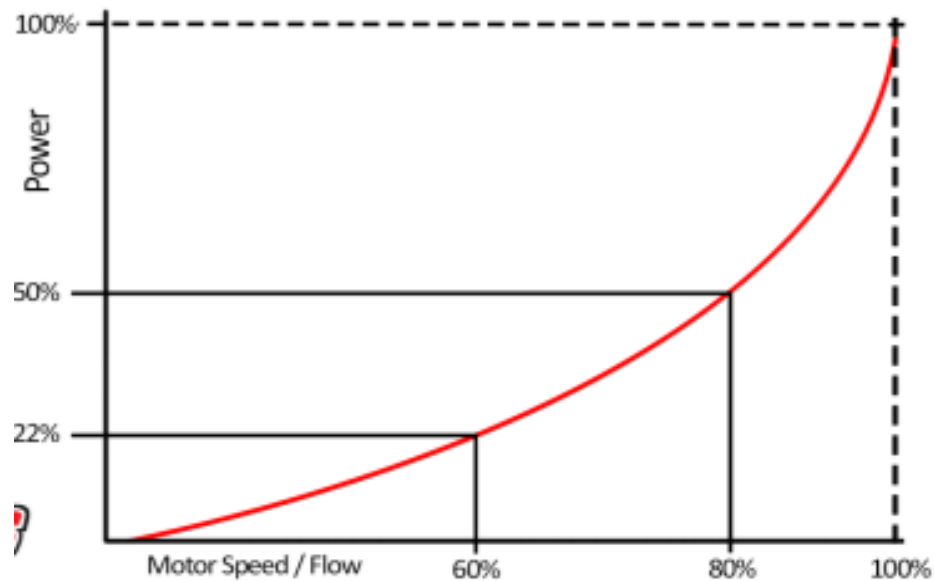

Figure 3 : Benefits of a variable frequency drive [2]

- Creating variance in the speed of the motor provides energy savings.
- In many of the motors VFDs are applied to, the reduction in energy used by the motor varies with the cube of the motor's speed.
- That means that a 25% reduction in the motor's speed produces an almost 60% decrease in energy used.
- A 1 °C cooling water temperature increase may increase the A/C compressor electricity consumption by 2.7%. A 1 °C drop in cooling water temperature can give a heat rate saving of 5 kcal/kwh in a thermal power plant.
- The expanding of water spreading area by the using additional cooling towers will help to reduce the condenser water leaving temperature very economically.
- Then higher fan speed is not required to cool low volume of water. Therefore, smaller approach can be achieved at low cost.
- This low temperature condenser entering water will increase the efficiency of chiller system.
- Usage of more cooling towers will increase the operational cost. Therefore, optimum number of cooling towers and optimum level of cooling tower fan speed

to be identified and declared as a norm and guideline for HVAC system designer, purchaser and operators.

1.3. Problem Statement / Research Gap

Water-cooled chillers are rated at different conditions to that of cooling towers. Local operating conditions of a cooling tower is 37°C tower inlet & 32°C tower outlet and 27°C being entering air wet bulb. AHRI rated water cooled chiller operating conditions are 30°C condenser inlet & 35°C condenser outlet and 24°C being entering air wet bulb. Most of the water cooled chillers operating at local conditions, however they are rated at AHRI conditions, which is conveniently ignored by both designers and the HVAC contractors.

- ✓ Rated overall system efficiency of HVAC plant ≤ 0.90 kW/TR
 - ✓ Rated Water side efficiency ≤ 0.65 kW/TR
 - ✓ Water side efficiency = Chiller efficiency + CT Efficiency + CW Motor
 - Efficiency + CHW Motor efficiency
 - ✓ Rated Chiller Efficiency ≤ 0.52 kW/TR
 - ✓ Rated CT efficiency ≤ 0.03 kW/TR
-
- Is there a way to increase CT efficiency?
 - What is the relationship between CT efficiency and Chiller efficiency?
 - May the usage of Stand by Cooling Towers or additional cooling towers be helped to reduce the condenser inlet water temperature?
 - Is the operating of additional cooling towers economical?
 - Is it possible to get smaller Approach?
 - May it be helped to overcome the effectiveness of high Wet bulb temperature on leaving water temperature of CT?

1.4. Aim

Optimization of cooling tower configuration for better system efficiency

1.5. Objectives

1. To understand state of the art of HVAC system and cooling towers
2. To analyze performance of existing HVAC systems and cooling towers
3. To design optimum cooling tower configuration
4. To evaluate the proposed configuration
5. To prepare a guideline for operating the HVAC system by optimizing the cooling tower efficiency.

1.6. Methodology

1. Literature review is used to understand state of art HVAC systems & Cooling towers and enhanced by visiting and inspecting appropriate installations.
2. Selected HVAC installations with BMS were used to analyze the performance of existing HVAC system. BMS system or a Chiller Plant Manager (CPM) is a useful tool to analyze the performance in real time.
3. Various combinations of cooling towers are operated and also cooling tower fan speeds are varied to obtain data to find the optimum cooling tower configuration.
4. Evaluation of the proposed configuration should have carried out comparing bench mark data from ASHARE 90.1 energy standard.
5. Operating guidelines for HVAC system was prepared as per the suggestions given by ASHARE Handbook HVAC Applications. Best combination of cooling tower with optimum fan speed to be selected at the lowest power consumption.

1.7. Work Flow Chart

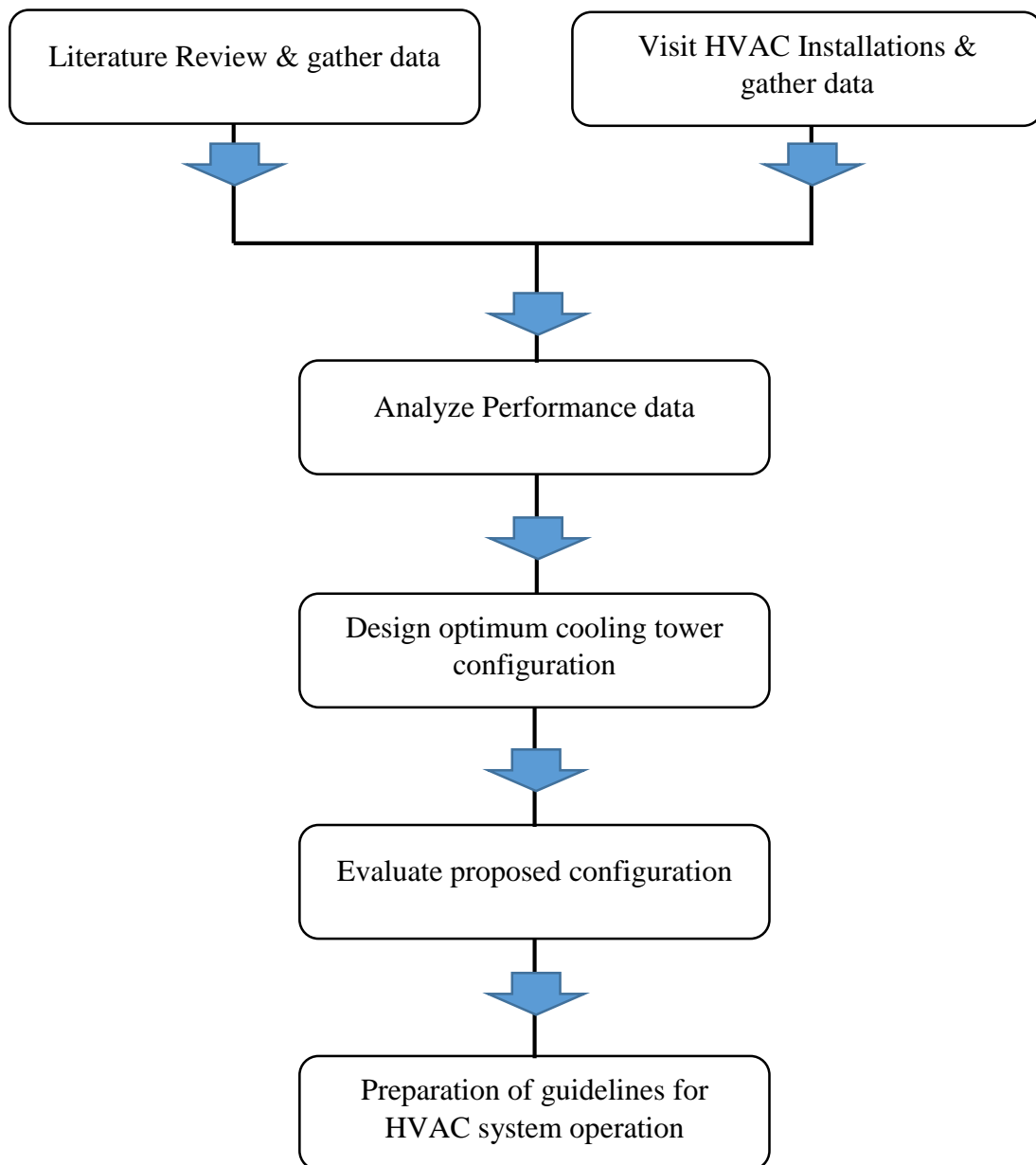

Chapter-2

Literature Review

Literature review is based on Book section, research reports, Journal articles, conference proceedings regarding energy efficiency in HVAC systems & improvements to cooling tower heat rejection.

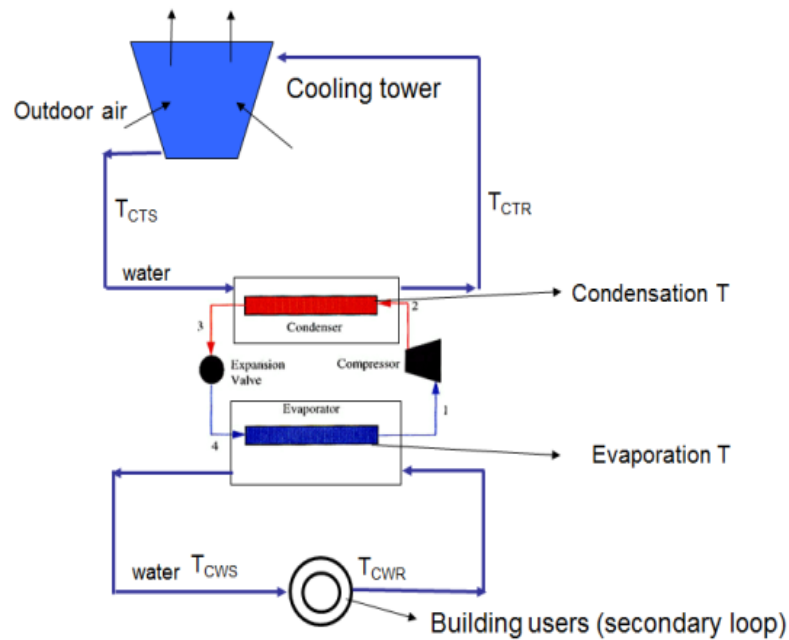

Figure 4 : Configuration of water cooled chiller plant [3]

2.1. All-Water Air Conditioning System

Basic All-water air conditioning system was mentioned in 1.1 Background and it is a very popular HVAC system in large building complexes and commonly known as “central air conditioning systems”. Definition for central air conditioning is the refrigeration machine centrally located. Chilled water produced by the chillers are circulated via CHW piping circuit through CHW fan coil units and Air Handling Units.

2.2. Major Items of Central Air-Conditioning System

- i. Water Chillers
- ii. Air handling unit
- iii. Fan coil unit
- iv. Heat Rejection Equipment
- v. Chilled water (CHW) piping circuit
- vi. Condenser water (CW) piping circuit

2.2.1. Chiller



Figure 5 : Chiller Plant [4]

An apparatus that removes heat from a liquid via an absorption refrigeration or vapor-compression cycle is called as **Chiller**. Then this liquid can be circulated via a heat-exchanger to cool apparatus or other process stream (such as process water or air). As an essential by-product, refrigeration generates waste heat that must be emitted to atmosphere or for better efficiency, recovered for heating systems.

To dehumidify air and cool in mid to large scale industrial, commercial and institutional facilities Chilled water is used. Condenser heat rejection of the chiller can be air cooled, evaporative cooled or water cooled. Water cooled chiller can give environmental impact advantages and better efficiency over air cooled chillers.

Major components of chillers

- i. Refrigeration Compressors
- ii. Air-cooled or water-cooled Condensers
- iii. Refrigerant Metering Device or Expansion device (TXV)
- iv. Water cooler or Evaporator known as the chiller
- v. Variable Speed Drive (VSD) for compressors

2.2.2. Air handling unit

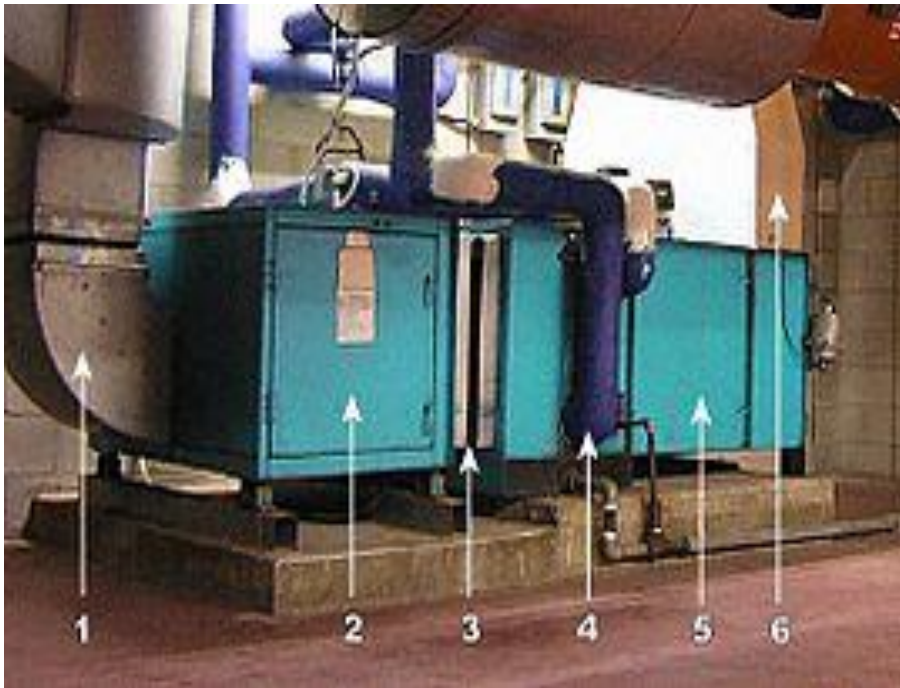

Figure 6 : Air handling unit [5]

An Air Handling Unit (AHU); air flow is from the right to left in this case. Some AHU components shown are

1. Supply duct
2. Fan compartment
3. Vibration Isolator
4. Heating and / or cooling coil
5. Filter compartment
6. Mixed (recirculated + outside) air duct

An **air handling unit (AHU)**, is used to control and circulate air of heating, ventilating, and air-conditioning (HVAC) system. An AHU is generally a large steel box having a heating or cooling elements, AHUs are used for Constant Air Volume systems (**CAV**) or Variable Volume Systems (**VAV**).

There are smaller AHUs which may only contain a blower, coil and air filter. These simpler units are called fan coil units (FCU) with blow through fan configuration.

Makeup Air Unit (MAU) or **Dedicated Outdoor Air System (DOAS)** is a larger AHU which conditions hundred percent outside air and there is no circulation.

2.2.3. Fan coil unit



Figure 7 : Fan coil unit [6]

A simple unit which having a cooling and/or heating coil or heat exchanger and fan is called as **Fan Coil Unit (FCU)**. It is commonly used in industrial, commercial and residential buildings. A FCU is a diverse unit occasionally using ductwork. It

is used to maintain the temperature in installed area or multiple areas. It is maintained by a manual on/off switch or by a thermostat, which maintain the water output to the coil using a balancing valve and/or the fan speed.

Because of their flexibility and simplicity, FCU are used in individual zones that can be controlled by their own temperature controller. There are different types of FCUs are available, such as vertical floor mounted, ceiling suspended, ceiling concealed ducts, ceiling cassette, high wall & column type.

2.2.4. Heat Rejection Equipment

Energy absorbed by the refrigeration system with heat of compression is dissipated at the air-cooled condenser or at the cooling tower.

It is obvious that the efficiency of the heat rejecting equipment has a major role in achieving overall energy efficiency of the air conditioning plant.

Heat rejection equipment of the Air-cooled chiller is air cooled condensers. Generally their configuration is V-type finned tube coils, where condensing hot high pressure refrigerant flows inside the tube and atmospheric air circulates outside.

In this study, energy efficiency of central chiller system is analyzed in depth to find the best optimum cooling towers configuration.

2.3. Cooling Tower



Figure 8 : Cooling Tower [7]

A **cooling tower** is a heat-removing unit that removes heat picked up by the refrigeration system & dissipated to environment by evaporation of water. Hot water from the refrigeration condenser is brought to the cooling tower and spray down against the atmospheric air flow, which evaporates some portion of circulation water and cools it to closer to entering air wet bulb temperature.

All water-cooled chillers utilize cooling towers as heat rejection equipment. Cooling towers can be categorized as Open type and closed type towers. Open type towers are Natural draught towers, induced draught towers, cross flow towers, & forced draught towers.

Cooling towers differ in scale from small roof-top units to huge hyperboloid structures which can construct up to 100 meters in diameter and 200 meters tall, or rectangular structures which can construct over 80 meters long and 40 meters tall.

Basically, a cooling tower is a form of heat exchanger. Process heat removal is the role of cooling tower, generally from the condenser of a chiller or a direct manufacturing process. Three types of heat exchangers are available. They are plate and frame, shell and tube and open quenching. Mostly we do not discuss the open quenching type, except in rare occasions. Everyone of each has its advantages and disadvantages. Plate exchangers can clog simply and because of that they are normally not used in dirty environment. Plate exchangers are more efficient than shell and tube, but cleaning of shell and tubes are easier. There is a limitation to plate exchangers' efficiency. It is depending on the size of the unit.

Towers are classified into closed and open systems. In the closed system, the liquid or vapor is not exposed to the surrounding for evaporative cooling. Open system is the most effective than closed system, but it is generally not the choice of engineers, as impurities can be accumulating into the working fluid and subsequently into the heat exchanger. It can both effect on the efficiency of the exchanger and also affecting permanent damage.

Among the classifications of closed an open, further towers can be divided into forced draft, where the fan is placed in the dry, entering air or induced draft, where the fan is placed in the moist, exiting air. In addition to that, the tower can have a cross-flow of air movement or a counter-flow of air movement. The air is flowing horizontally in the cross-flow type across the fill since the water is pumped from the bottom to the upper of the tower and is cooled and it is dropping again and again. The air is flowing upward, and the water drops along the medium, or fill in the counter-flow type. When consider about these two types, counter-flow towers use more energy/ton of cooling than cross-flow towers. All these types have its advantages and disadvantages.

Capacity of the cooling tower is design to remove the heat load against cooling load and compressor heat load. Compressor heat load is nearly 15% to 20% of cooling load. Therefore, capacity of the cooling tower is basically selected as 125% of cooling load.

Condenser water (CW) flow rate is determined by using the Specific Heat formula. Generally at AHRI conditions, CW flow rate could be calculated as 0.054 L/s.kW or 3.0 GPM/TR

2.3.1. Cooling Tower Design Consideration

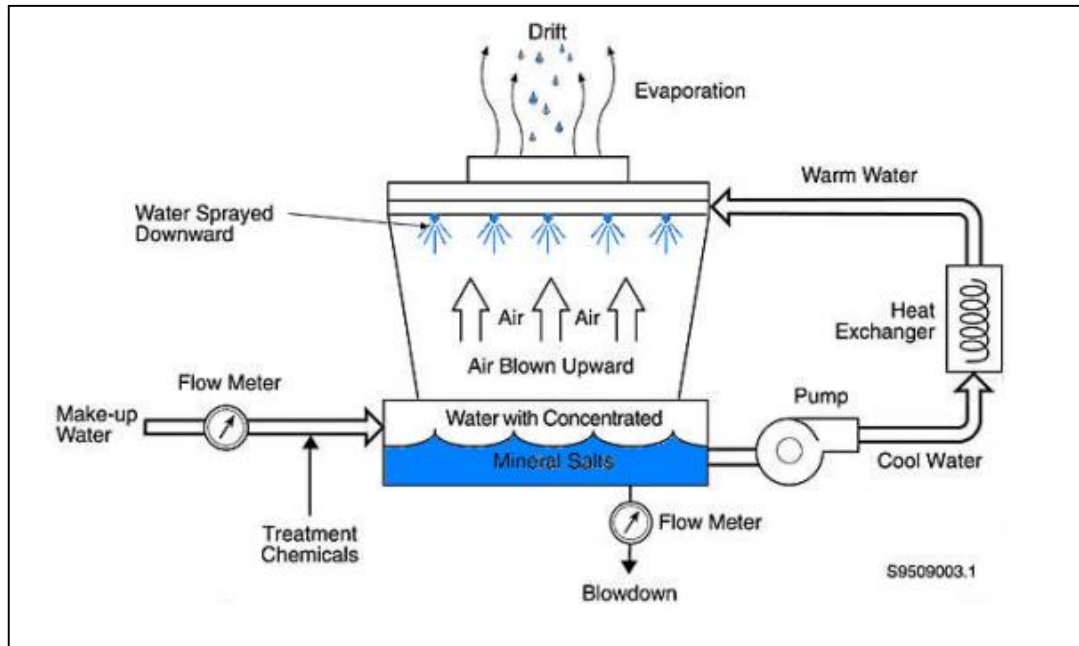

Figure 9 :Cooling tower schematic diagram [8]

After determining the cooling capacity of chillers, the designer selects appropriate cooling tower from various makes.

- Cooling tower design parameters are
 - i. Cooling tower Range
 - ii. Cooling tower Approach
 - iii. Entering air wet-bulb temperature
 - iv. Mass flow rate of water
 - v. Heat rejection rate
- Other design characteristics to consider would be
 - i. Reducing drift loss
 - ii. Complying with CTI certification (CTI certified tower)
 - iii. Fan break horse Power
 - iv. Numbers of cells

- v. Make up water requirement
- vi. Chemical treatment for water and complies with ASRAE guideline for protection of Legionnaires' disease.

2.3.2. The cooling tower Categorization

- i. Open type
- ii. Closed type

2.3.2.1. Open type towers

- i. Induced draught – Counter flow
- ii. Induced draft - Cross flow
- iii. Forced draught – Counter flow
- iv. Natural draught – Counter flow

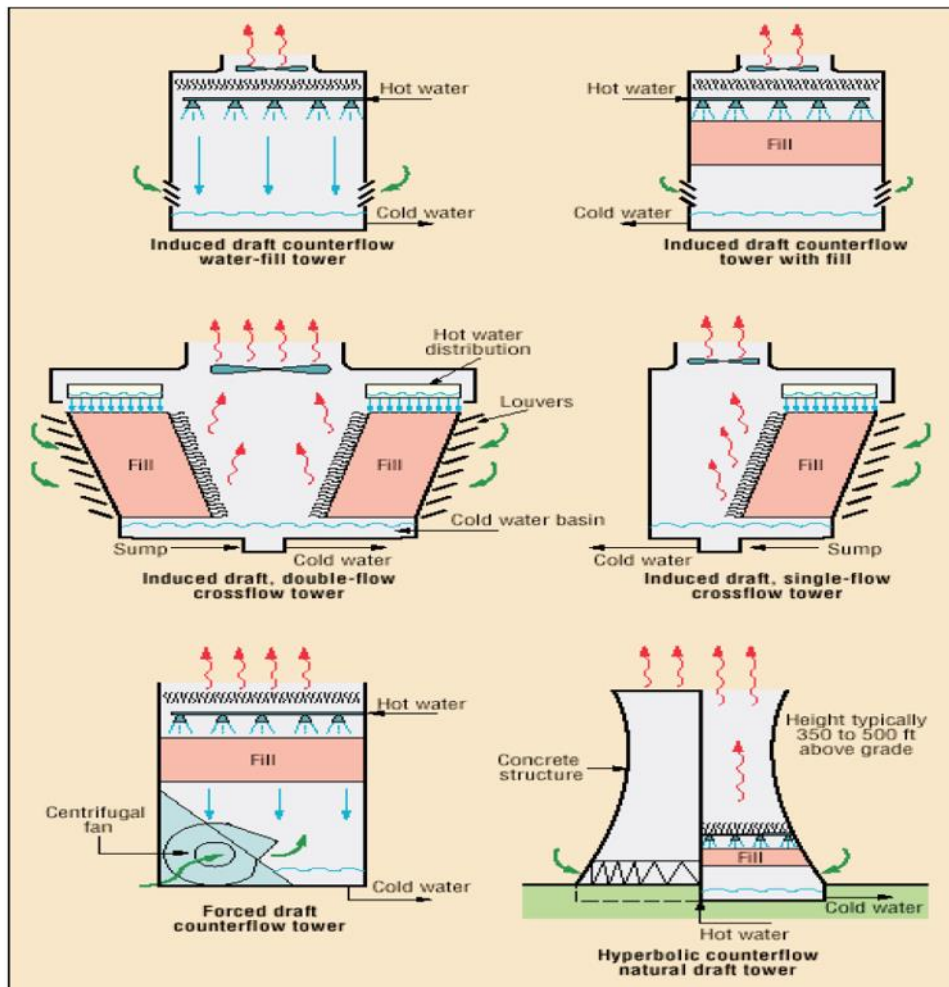
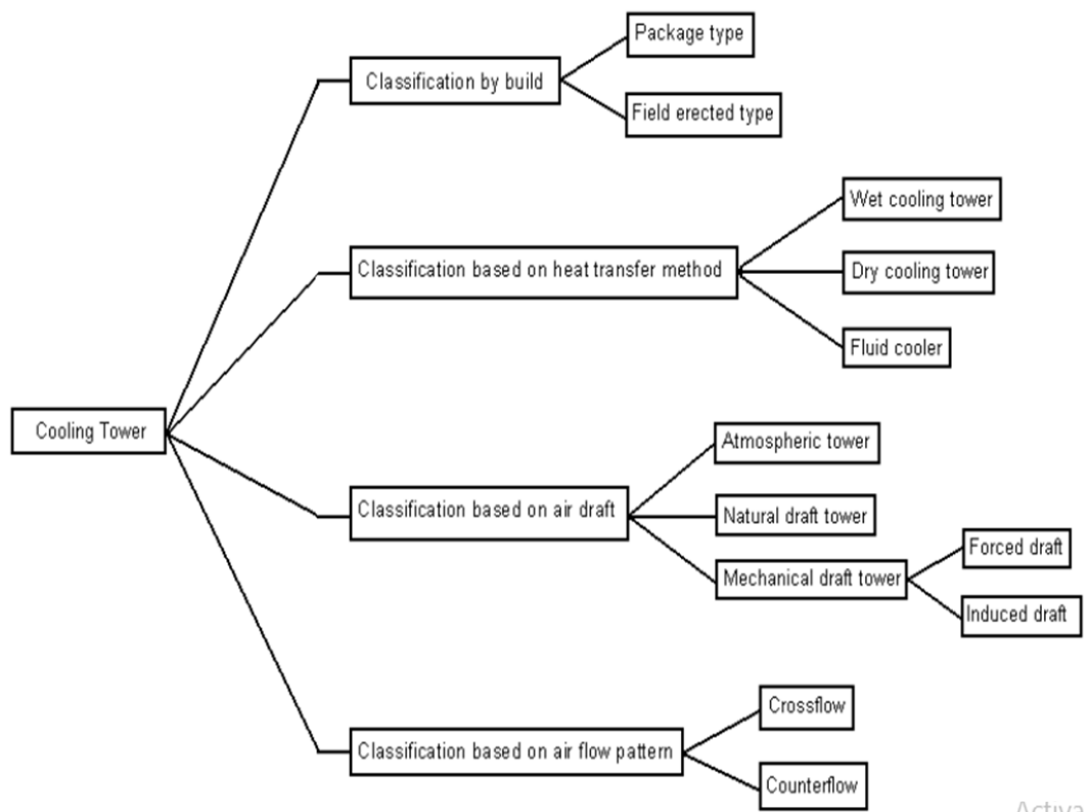

Figure 10 : Open type cooling towers [9]

2.3.3. Classification of Cooling Tower [8]



Activat

2.3.3.1. Classification by build [8]

a. Package Type

Package Type cooling tower is considered as a compact machine. It's pre-assembled and possible to carry on a truck. The capacity of this type units is comparatively very low. Therefore, Package type units are generally used to facilitate for low heat load requests.

b. Field Erected Type

Petrochemical plants, Petrochemical plants, Power plants and Steel processing plants are the most suitable places to install this Field erected type cooling towers

2.3.3.2. Classification based on heat transfer method [8]

a. Wet Cooling Tower

Evaporation principle is the base of operation of Wet cooling towers. Generally, water is the working fluid as well as evaporated fluid of the tower.

b. Dry Cooling Tower

This type Dry cooling towers are operated base on Convective heat transfer method. This heat transfer is carried out in between working fluid and Ambient air across the separation surface. It's like a tube to air heat exchanger. There is no evaporation involved.

c. Fluid Cooler

There is tube bundle which carries working fluid and applied fan-induced draft and spray clean water on the tubes. Performance of hear transfer of Fluid cooler and wet cooling tower are much closer.

2.3.3.3. Classification based on air draft

a. Natural Draught Tower

An atmospheric tower contains a big rectangular compartment with louvered walls on two opposed side. Suitable tower fills are packed in it. Natural air flows in to the tower via louvers.

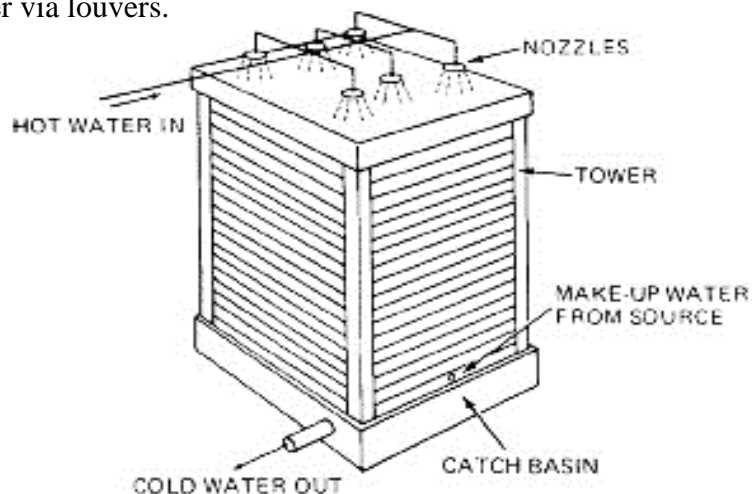

Figure 11 : Natural draught tower [10]

b. Natural Draught Hyperbolic Tower

The natural draft or hyperbolic cooling tower design to use of the variable temperature between hot air in the tower and outside air.

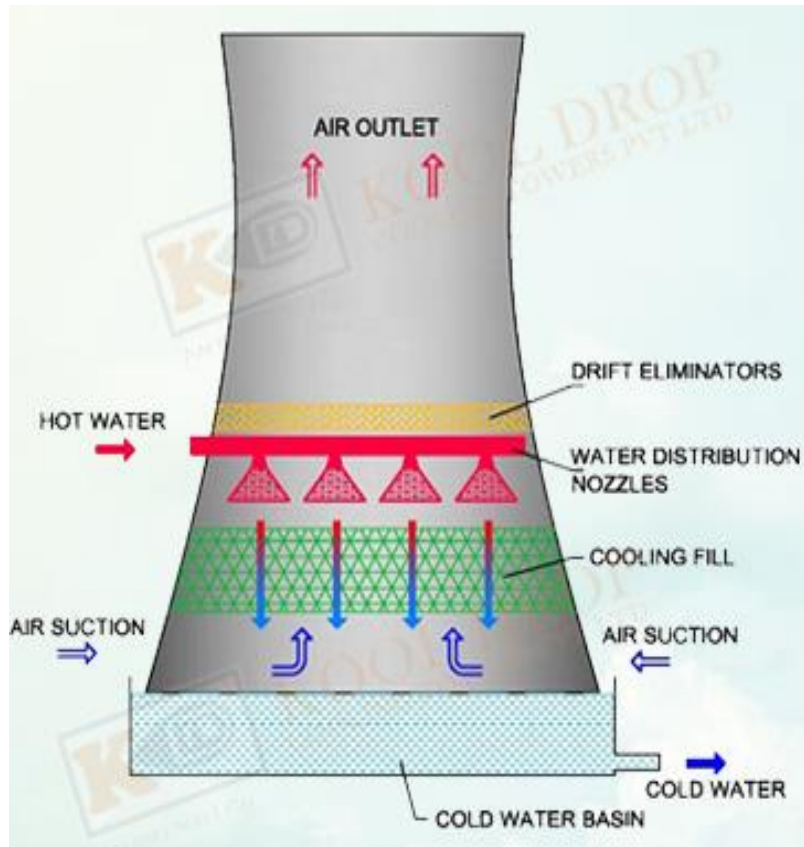

Figure 12 : Natural draught hyperbolic tower [11]

c. Mechanical Draft Cooling Towers

Instead of using natural draft towers, most of the places mechanical draft towers have been used. Natural draft tower construction is very difficult, because its' very large shape and cost.

Air inside the Mechanical Cooling tower is drawn or forced over the circulate fluid by large fans of the tower. They are categorized in two classes.

i. Induced draft

Here, pulls air through the tower by the fan which is installed top of the tower. The fan brings moist air with the heat from the tower.

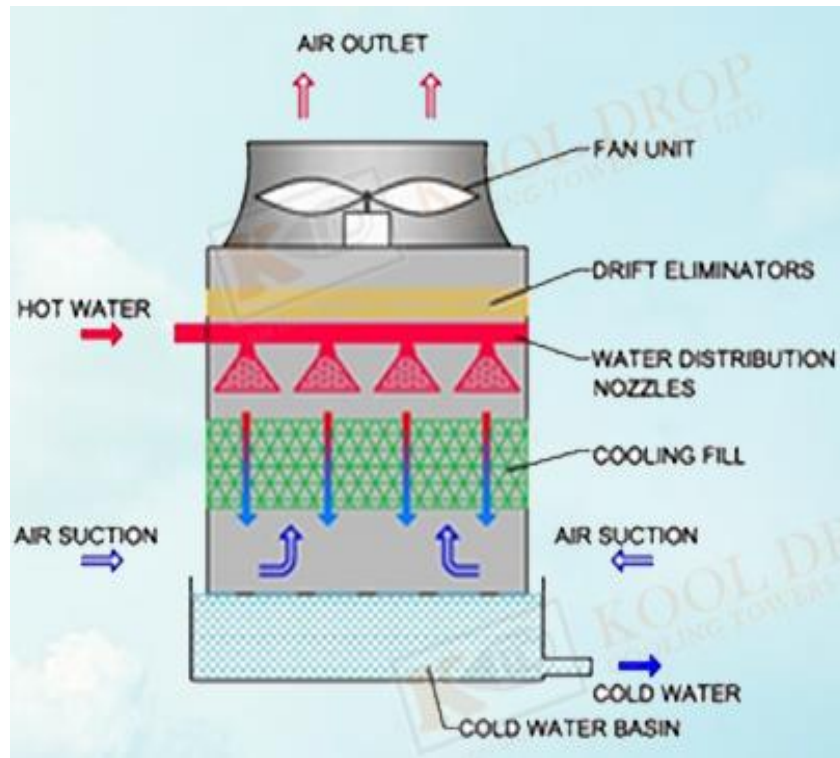

Figure 13 : Induced draft [12]

ii. Cross flow Tower

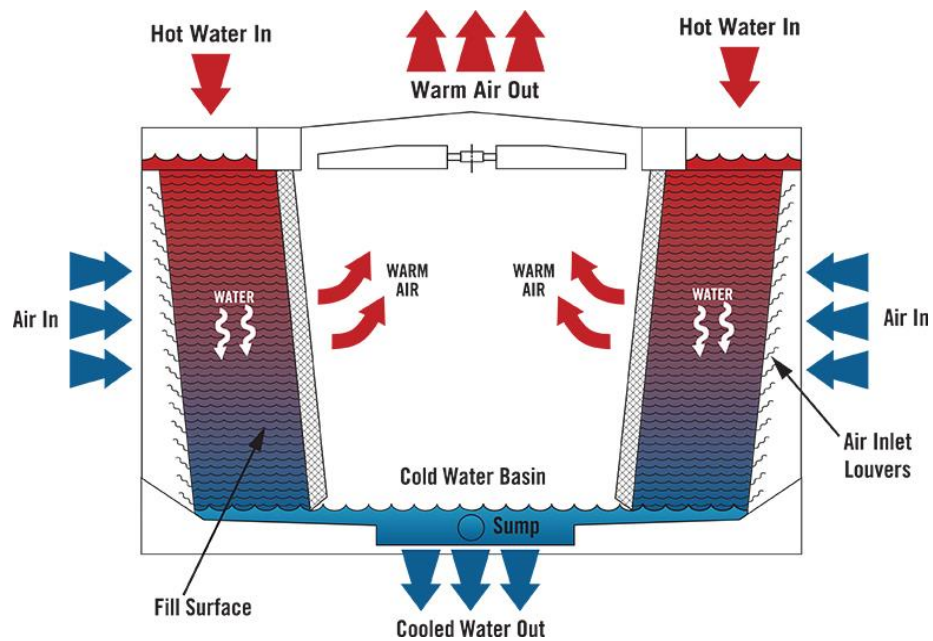

Figure 14 : Cross flow tower [13]

Air stream is blowing perpendicular to water drops in Cross flow cooling towers. Air flow come in to the tower through vertical faces to contact filler material.

iii. Forced draft

Air flow is forced up wards against falling water from sprays. This is the highest efficient tower among all types. Most of large refrigeration systems comprises of forced draught towers, because it has a smaller foot print.

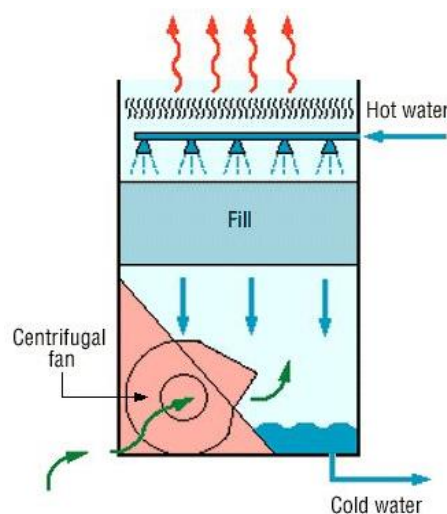

Figure 15 : Forced draft [14]

2.3.4. Components of a Cooling Tower [8]

2.3.4.1. Structural Components

Corrosion is more likely to have in cooling systems. There is relatively high velocity warm water circulate deferent type of metal parts. Due to these effects corrosion is rapidly developed in cooling systems. System Deposits due to dirt, silt, scale, debris, bacteria, dissolved solids and, various gases, create complicated of the problem. Even a small change of pH value of cooling water causes a quick development of corrosion. There is high Oxygen content in Open recirculating systems. Therefore, corrosion effect is very high.

Structural components can be named as: fan cylinders, fan deck, cold water basin, water distribution system, fill, drift eliminators, casing, framework, louvers and mechanical equipment supports.

1. Cold water basin

There are two basically important activities are done by Cold Water Basin. It's act as the primary foundation of cooling tower and Collect water come into the tower and transit.

2. Tower framework

The Material which generally used for the framework erected in the field are fiberglass, concrete and wood. It's not frequently satisfy building code or any other preference

3. Water distribution system

Pipes may be installed underground to reduce thermal expansion, Axial loading, and freezing. Hence installation cost and repair cost also minimized. The tower and risers' connection must be independently supported because Structure of the tower and pipes should be independent.

4. Fan deck

The fan deck is measured as a part of the structure of cooling tower and it's used as a diaphragm for conveying live and dead loads from the cooling tower. It makes provision to place fan cylinders, and can reach to the water distribution systems and mechanical devices through the deck. Material of tower frame and Fan deck should be compatible.

5. Fan cylinder

Proper air flow through the tower is created by the Fan cylinder. Efficiency of cooling tower is badly reduced by incorrect design of fan cylinder and increased significantly by proper design of fan cylinder.

6. Mechanical equipment supports

Stainless steel supports incur significant extra cost. Therefore, hot dipped galvanized carbon steel supports are commonly used.

7. Fill (heat transfer surface)

Fill has been design to get maximum water and air contact surface area and contact time. It's significantly effect to the efficiency of the tower. Film type and splash type are the basic categorizations of fills.

Splash type fill interrupts vertical flow of water and splash water flow with the cascade effect by using parallel splash bars. It is characterized by low air pressure losses. It is providing enough support to the water.

Film type fill, spread water as thin film and make huge surface area to contact with air flow. It has ability to deliver more productive cooling capacity than same size cooling tower, but water distribution of this system is very poor.

8. Drift eliminator

Drift eliminators eliminate turn the direction of water to carry away with air floor. As a result of this, water drops deposits on the surface of eliminator and drop into cooling tower.

Eliminator are categorized by the figures of change the directions or “passes”, with an increase in the number of passes usually accompanied by an increase in pressure drop. Drift eliminators remove entrained water from the discharge sair by causing it to make sudden changes in direction. The resulting centrifugal force separates the drops of water from air, depositing them on the eliminator surface, from which they flow back into the tower.

Eliminator are normally classified by the number of directional changes or “passes”, with more passes involvement generally cause high pressure drop.

9. Casing

The casing of Cooling Tower performs to hold water in the tower, act as a plenum for cooling tower fan, and convey loads of wind to the framework of the tower. It should be strong to get diaphragm effect, be corrosion resistant, be water tight and have fire resistance abilities, and also resist to the weather.

There are inlet louvers consist of properly designed crossflow tower. But, lovers are rarely required for counter-flow towers. Their determination is to hold circulating water within the boundaries of the tower, and air balance over the fill.

2.3.4.2. Mechanical Components

1. Fans

The purpose of the cooling tower fans is to move large volumes of air with efficiency and with minimum vibration. The fans must be made of materials that are compatible with the design of the cooling tower They also not corrode due the effects of the environment in which they operate.

- a. Propeller fans: They are capable of moving large volumes of air at low static pressure. They are also less costly and could be used on a tower of any size, and are able to work at develop high efficiency. However, their usage is very limited due to the fact that projects of big magnitude are not always present
- b. Automatic variable-pitch fans: These fan can adjust to airflow through the tower according to ambient conditions or variable load.
- c. Centrifugal fans: Their ability to operate at high static pressures makes them the ideal choice for indoor installations. But their use is limited to

small installations as they are not very efficient and also not able to handle large volumes of air.

All propeller type fans are governed by common laws:

- i. The capacity varies proportionately with the speed ratio, and the pitch angle of the blades in connection with the plane of rotation.
- ii. Horsepower of the fan varies against the cube of the capacity ratio.
- iii. Static pressure of the fan varies against the square of the capacity ratio
- iv. At constant capacity, the static pressure and fan horsepower vary directly with air density.

2. Speed reducers

The optimum fan speed of a cooling tower is hardly coinciding with the most effective speed of the motor. As such devices mechanisms, such as power transmission unit or speed reduction unit is necessary to be installed between the motor and the fan

3. Drive shafts

Power transmission from motor output shaft to the input shaft of gear reduction units is taken place through drive shaft.

4. Valves

Controlling and regulating the water flow through the lines to the tower are achieved by means of valves. Valves used in cooling tower applications are:

- a. Stop valves: They are used on both crossflow and counter flow towers to control flow in multiple-riser towers, and to stop flow in a specific riser for maintenance of cell.
- b. Flow-control valves: They are considered to discharge to the surrounding, and basically as the end-of-line valves.
- c. Make-up valves: These are valves operated to automatically replace the normal water losses from the system.

2.3.4.3. Electrical Components

1. Motors

The purpose of the electric motors is to drive the fans on mechanical draft cooling towers. The motors have to be constructed in such a way that they can withstand extreme and adverse operating conditions found in the environment.

2. Motor controls

The purpose of motor controls is to start and stop the fan motor. They also protect the motors from overload or power fluctuations/failure, thus assuring uninterrupted, reliable and safe cooling tower operation. They are not always supplied as a part of the cooling tower contract. However, they are so important to the operation of the system, they merit adequate consideration in terms of selection of the controls and wiring of them.

3. Wiring system

Designing of the wiring system should be done considering all requirements. The system must be capable to handle the power requirement of the motor and should consider the length of the supply lines in designing the cable size and type. Available voltage and the stability of the available power supply line is also important factors.

2.3.4.4. Tower materials

Long life of the tower is very important in constructing towers. In early days towers were constructed using wood and cold-water basins were constructed using concrete. In modern days galvanized steel, stainless steel, fiber and plastic are used for such fabrications since they are more durable and corrosive resistant.

1. Frame and Casing

Cooling tower structure with wooden are still available. But more components are fabricated with different materials. Such as glass fiber casing around the frame of wooden, steel cold-water basin and plastic fill. Casing and basin of many towers are constructed with galvanized steel. Stainless steel Casing and/or basin are made at high corrosive atmosphere. Sometime large towers are made with concrete. Many cooling tower casing and basing are made with Glass fiber, because they protect from harmful chemicals and increase the life of cooling tower.

2. Fill

Normally fill is made out of PVC, polypropylene and other polymers. If the water condition require splash fill treated splash fill is still in use. If the water is free of debris film fill is used for application since they are having greater heat transfer efficiency.

3. Nozzles

Nozzles are normally made out of PVC, ABS, polypropylene and glass-filled nylon.

4. Fans

Aluminum, glass fiber and hot-dipped galvanized steel are commonly used as fan materials. Centrifugal fans are often fabricated from galvanized steel. Propeller fans are made from galvanized steel, aluminum, or molded glass fiber reinforced plastic.

2.3.5. Operation Considerations [8]

1. Water make-up

Evaporation, drift and blowdown are main reasons for loss of water in operation. Drift (water entrained in discharged vapor) is estimated between 0.1 to 0.2% of the supply water.

2. Cold weather operation

Even during cold weather months, the plant engineer should maintain the design water flow rate and heat load in each cell of the cooling tower. If less water is needed due to temperature changes (i.e. the water is colder), one or more cells should be turned off to maintain the design flow in the other cells.

The water in the base of the tower should be maintained between 60 and 70°F by adjusting air volume if necessary. Usual practice is to run the fans at half speed or turn them off during colder months to maintain this temperature range.

2.3.6. Tower Problems [8]

Contamination of water is a main problem especially in open recirculating cooling systems. Contamination could be happened either by make-up water or polluted air. As the cooling water evaporates, contaminants get more concentrated. High concentration of impurities in open recirculating systems will create serious problems as follows.

1. Scale

Scale formation reduces the heat transfer efficiency and resulting high fuel cost and unexpected plant down time. If the system is blocked heat transfer could go down below the lower limit and plant shut down is required to clean the system. Mineral scale is the most common scaling problem in present systems. Since these minerals are poor in heat transfer plant efficiency might reduce to very low level and creating financial problems as well.

Calcium carbonate, magnesium silicate, calcium phosphate and iron oxide are most commonly found inorganic mineral compounds found in cooling water systems. Even though these compounds are dissolve in water they tend to form scaling if the concentration is uncontrolled. Scaling can happen in both heat transfer areas and supply pipe lines. Mineral concentration, water temperature, pH value are factors of scaling.

When the temperature of the water is higher solubility of mineral becomes low. pH value of the water, concentration and temperature are the most critical factors of scaling. In most open recirculating systems are having above factors to help high scaling and scale inhibitors are added to control the situation.

2. Fouling

From both external and internal sources contaminants could enter the cooling system. Even though the makeup water is purified it could contaminant with substances which are not good for proper system operation. Cooling tower itself get dirt from air.

The solid coagulate as they strike with each other in the water. Low velocity of water, laminar flow and rough metal surfaces within heat exchanger allow masses of solids to settle and deposit on the metal. These deposits results in inefficient heat transfer. Fouling is normally controlled by mechanical and chemical cleaning process.

3. Microbiological growth

In cooling water systems, it is easy to grow microscopic organisms. Temperature and the pH value of the water is perfect environment for the microbial growth. Algae and fungi are commonly found in cooling water systems and cause serious damages. Microbiological fouling can cause:

- a. Loss of energy
- b. Low heat transfer efficiency
- c. High corrosion and pitting
- d. Loss of system efficiency
- e. Loss of structural integrity

4. Corrosion

Corrosion is one of main issues in water cooling systems. Since the water contain oxygen due to contact with air steel get corroded easily. Corrosion reduces the cooling efficiency and the life time of the product. The final result could be high cost for replacement and regular plant shut downs.

It is observed that most cooling systems made out of metal are vulnerable to corrosion. Warm water and high velocity of the flow are other factors of high corrosion in metal systems. pH value of the water is also a factor in high corrosion.

2.3.7. Maintenance and Water Quality

Mechanical damage to the fill is the first thing when the exiting water temperature is higher than it must be. There are three types. They are splash, fill-film and trickle type. Water is broken into droplets in the first type, in the fill-film type water flows down the surface and the trickle type is a both of above. Because of the mechanical

damage, dirt, scale or biological materials (algae), their effectiveness can be reduced.

Water evaporation in a system can be estimated as 3gpm per 100 ton of cooling. This evaporated water should be added to the system to operate properly. Drift can be 0.05% to 0.2% per day which should be added again to the system. The result in adding water is increasing concentration of contaminant of the water. The amount blows down of contaminant water divided by the amount of make-up water is called "Concentration ratio" and it's calculated in cycles. This is calculated by TDS, PH, conductivity and alkalinity. Concentration ratios can be up to 6, but generally it's maintained around 2-4. There can also be dissolved solids (usually CaCO_3) and bacterial growth. Sulfuric acid generally used for treatments. But sulfuric acid is an aggressive corrosive, and they should be used in combination with an anti-corrosive chemical. Measurements should be taken and list of items to be analyzed. Ozone injection and side stream filtration are other methods to control these contaminants. All type of treatment (for deposition, microbes, and for corrosion, etc.) are affected each other. [15]

2.3.8. Water Loop Enhancements

The distribution system could be dissociated to permit numerous pumps to be operated or to allow to utilization of variable speed drive motor to complement tower requirements. It is proposed that flow could be slowed down to save energy as a result of rapid improvement of chiller efficiencies over the last few years. The pumping savings were obtained by the reduction of a tower from 3 gpm to 2 gpm, which is better than the offset the additional expenditure of operating the chiller. there is a claim that capital cost of pumps, piping and fans could be substantially reduced by designing the flow rate at a slower speed. However, This has been disputed in a new HVAC&R publication.

It is a justified factor that chiller efficiencies have been improved over the years. The variable speed drives could be connected to pumps of cooling towers to save the cost of energy. [15]

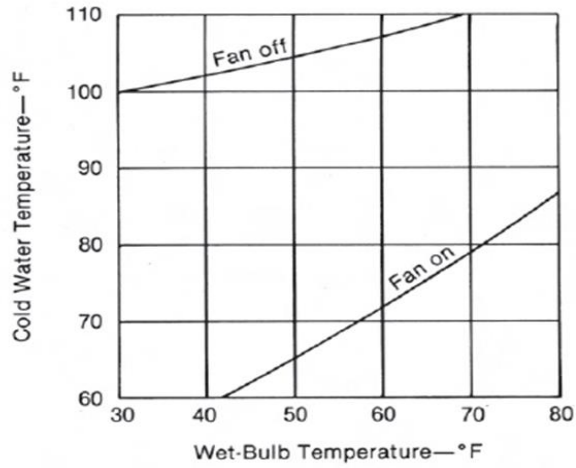

Figure 16 : Typical performance curve, Single cell tower with single speed motor [16]

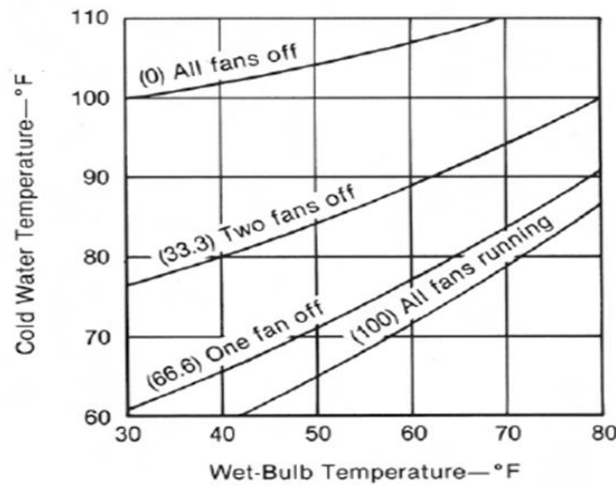

Figure 17 : Typical performance curve. Three cell tower with single speed motors [16]

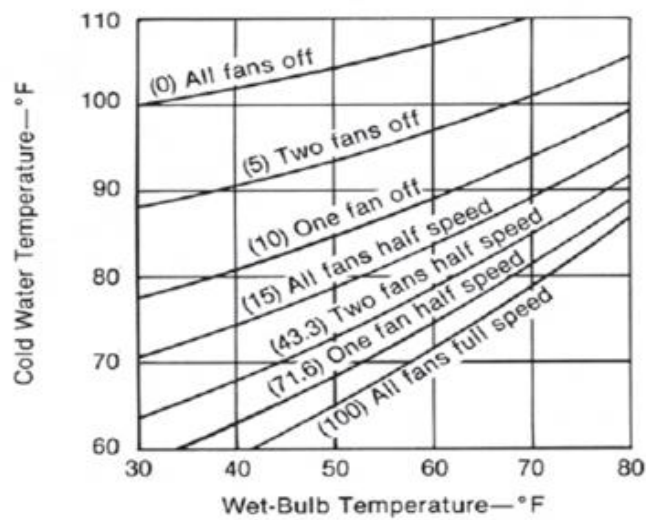

Figure 18 : Typical performance curve. Three-cell tower with two speed motor [16]

2.3.9. Tower Performance [15]

Several terms are to be defined in conversing on the performance of cooling towers. “Approach” is defined as the difference between the outlet cold water temperature of cooling tower and the ambient wet bulb temperature. Further, the difference between cooling water inlet and outlet water temperature could be defined as “range”.

The effectiveness of a cooling tower is calculated by three factors:

- i. The amount of heat that is added to the condenser (or other heat source) loop
- ii. The amount of water delivered to the tower
- iii. The ambient wet bulb temperature

ASHRAE and others establish and publish the design performance even though efforts at evaluating the chiller performance or its efficiency at different levels of tower performance seems to be elusive. Ideally, the most prominent design calculation, the e-NTU (Effectiveness - Number of Transfer Units) method is typically employed to specify equipment, whereas appraisal of an existing unit performance is generally conducted on an empirical basis; which is the instance where the tower and chiller combination are selected for the optimum performance of them at certain conditions and evaluated at different conditions. The chiller companies usually include these results within the specification (spec) sheets.

Over the years, design conditions have been improved became more realistic in nature. The original design conditions had been established in Atlanta, where, majority of systems within the country operated at their peak was only one percent. The chiller is within off peak during the hours below that temperature, which is in 90⁰F range. However, currently, chillers are designed where their peaks are in a justifiable range. Hence, current chillers run at an off peak performance in both above and below this design condition.

The majority of cooling effect of cooling towers are from the evaporation of water, although it could be used at higher humidity. Generally, approximately 1% of water

is evaporated in the process and requires replacement, whereas attention to be given in treatment of that water as evaporation improve the concentration of any contaminates. As previously explained, loss at cooling towers defines energy loss at chiller or compressor. Water within a tower which is not well maintained could be 10°F higher than design. Whereas, this could result in additional expenditure of 3.5% of energy for every degree warmer that cooling water becomes.

2.3.10. Measuring Performance

1. Operation

With the intention of be able to efficiently calculate the system's performance it is important to initially find the amount of cooling ton-hours it perform on a time basis. The idea of a cooling ton-hour is equal to the multifunction of a kilowatt-hour; it is one ton of cooling supplied for one hour of time. To determine cooling ton-hours, we required to recognize the cooling capacity of the system and same as its operation profile. Getting idea about the value of cooling ton-hours the cooling system provided it's possible we to measure energy, chemical and water usage on per cooling ton-hour basis. This take it easy to measure system performance through different sites. Additionally, cooling ton-hours be able to use to calculate total building cooling effectiveness when observing the use of chillers, water-side economizers and air-side economizers.

2. Capacity

Cooling towers are generally labeled by their cooling capacity. The cooling capacity shows the rate at that the cooling tower is transfer heat. The removal of 12,000 BTUs (British thermal units) per hour from water is same to One ton of cooling. Capacity of cooling towers at industrial or commercial sectors might choice from as few as 50 tons to 1,000 tons or more. Bigger requirements may be fulfilling with multiple cooling towers.

Common Header Systems

- Control Valves Are Essential to Guarantee Balance and Hydraulics
- Equalization Required

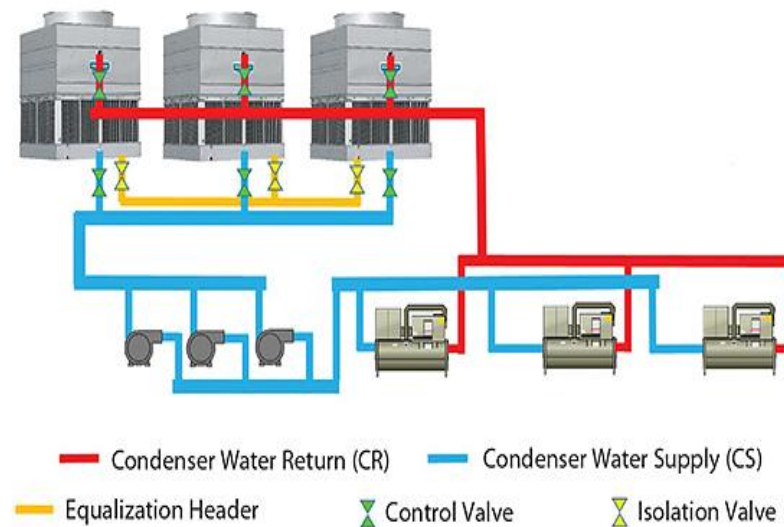

Figure 19 : Common header systems [17]

2.3.11. Measuring Parameters

Measured Parameters

- i. Wet bulb temperature of air
- ii. Dry bulb temperature of air
- iii. Cooling tower inlet water temperature
- iv. Cooling tower outlet water temperature
- v. Exhaust air temperature
- vi. Electrical readings of pump and fan motors
- vii. Water flow rate
- viii. Air flow rate

Performance Parameters

- i. Range
- ii. Approach
- iii. Effectiveness
- iv. Cooling capacity

- v. Evaporation loss
- vi. Cycles of concentration
- vii. Blow down losses
- viii. Liquid /Gas ratio

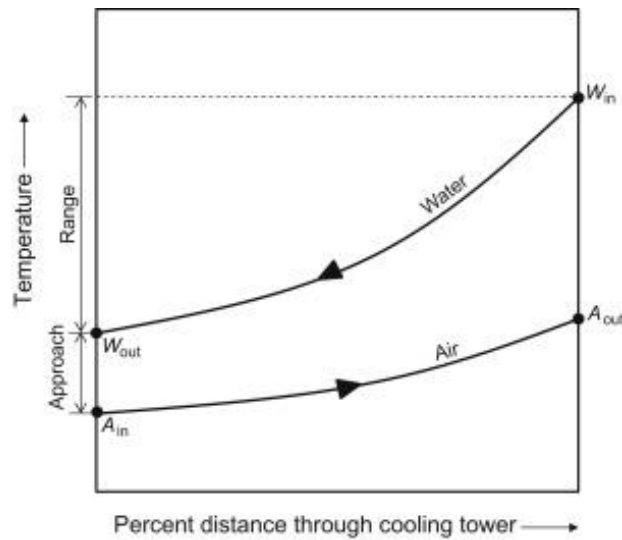

Figure 20 : Range and Approach [18]

i. Range

Difference between cooling water inlet and outlet temperature

$$\text{Range } (^{\circ}\text{C}) = \text{CW inlet temp} - \text{CW outlet temp}$$

High range = good performance

ii. Approach

Difference between cooling tower outlet cold water temperature and ambient wet bulb temperature:

$$\text{Approach } (^{\circ}\text{C}) = \text{CW outlet temp} - \text{Wet bulb temp}$$

Low approach good performance

iii. Effectiveness

$$\text{Effectiveness in \%} = \text{Range} / (\text{Range} + \text{Approach})$$

$$= 100 \times (\text{CW temp} - \text{CW out temp}) / (\text{CW in temp} - \text{Wet bulb temp})$$

High effectiveness = good performance

iv. Cooling Capacity

Heat rejected in kCal/hr or tons of refrigeration (TR) = mass flow rate of water
X specific heat X temperature difference

High cooling capacity = good performance

2.3.12. Right Selection of Cooling Tower

- i. Selecting a cooling tower
- ii. Fills
- iii. Pumps and water distribution
- iv. Fans and motors

1. Selecting a cooling tower

- i. Capacity
 - a. Heat dissipation (kCal/hour)
 - b. Circulated flow rate (m³/hr)
 - c. Other factors
- ii. Range
 - a. Range determined by process, not by system
- iii. Approach
 - a. Closer to the wet bulb temperature
 - b. Bigger size cooling tower
 - c. More expensive
- iv. Heat Load
 - a. Determined by process
 - b. Required cooling is controlled by the desired operating temperature
 - c. High heat load - large size and cost of cooling tower
- v. Wet bulb temperature - considerations
 - a. Water is cooled to temp higher than wet bulb temp
 - b. Conditions at tower site
 - c. Not to exceed 5% of design wet bulb temp

- d. Is wet bulb temp specified as ambient (preferred) or inlet
- e. Can tower deal with increased wet bulb temp
- f. Cold water to exchange heat
- vi. Relationship range, flow and heat load
 - a. Range increases with increased
 - Amount circulated water (flow)
 - Heat load
 - b. Causes of range increase
 - Inlet water temperature increases
 - Exit water temperature decreases
 - c. Consequence larger tower
- vii. Relationship Approach and Wet bulb temperature
 - a. If approach stays the same (e.g. 4.45 °C)
 - b. Higher wet bulb temperature (26.67 °C)
 - More heat picked up (15.5 kCal/kg air)
 - Smaller tower needed
 - c. Lower wet bulb temperature (21.11 °C)
 - Less heat picked up (12.1 KCal/kg air)
 - Larger tower needed

2. Fill media

Hot water distributed over fill media and cools down through evaporation

Fill media impacts electricity use

- i. Efficiently designed fill media reduces pumping costs
- ii. Fill media influences heat exchange: surface area, duration of contact, turbulence

Comparing 3 fill media: film fill more efficient

Table 1: Comparison of Cooling Tower Fill Types

	Splash Fill	Film Fill	Low Clog Film Fill
Possible L/G Ratio	1.1-1.5	1.5-2.0	1.4-1.8
Effective Heat Exchange Area	30-45 m ² /m ³	150 m ² /m ³	80-100 m ² /m ³
Fill Height Required	5-10m	1.2-1.5m	1.5-1.8m
Pumping Head Requirement	9-12m	5-8m	6-9m
Quantity of Air Required	High	Much low	Low

3. Pumps and water distribution

Pumps: introduce suitable VFD driven pumps

Optimize cooling water treatment

- i. Increase cycles of concentration (COC) by cooling water treatment helps reduce make up water
- ii. Indirect electricity savings

Install drift eliminators

- i. Reduce drift loss from 0.02% to only 0.003-0.001%

4. Cooling Tower Fans

Fans must overcome system resistance, pressure loss: impacts electricity use

Fan efficiency depends on blade profile

- i. Replace metallic fans with FBR blades (20-30% savings)
- ii. Use blades with aerodynamic profile (85-92 fan efficiency)

2.3.13. Improving Energy Efficiency of Cooling Towers [8]

The most important options to improve energy efficiency of cooling towers are:

1. Follow recommendation of tower manufacturer to keep the clearances around the towers and modify structure or relocate for designed air intake or exhaust
2. Fan blade angle to be optimized on load basis and/or Seasonal basis.
3. Correct uneven and/or excessive tip clearance of fan blades and improper fan balance
4. In old counter-flow cooling towers, old spray type nozzles can be changed to new square spray nozzles which do not clog
5. Splash bars can be replaced with PVC cellular film fill (self-extinguishing)
6. Nozzles can be installed to spray water in more uniform water pattern
7. Plugged cooling tower distribution nozzles should be cleaned regularly.
8. Flow of water to cooling tower hot water basins to be balanced
9. Hot water basins should be covered to minimize algae growth which help to fouling
10. Cycles of concentration (COC limit) take into the account and optimize the blow down flow rate
11. Slat type drift eliminators can be replaced with low-pressure drop, self-extinguishing PVC cellular units
12. Flows over huge loads to design values to be restricted.
13. Cooling water temperature to be kept to a minimum level by (a) separating high heat loads like air compressors, furnaces, DG sets and (b) detaching cooling towers from sensitive applications like condensers of captive power plant, A/C plants, etc.
14. Effectiveness, cooling capacity and approach are monitored to continuously optimize the performance of cooling tower, but side variations and seasonal variations to be considered.
15. Cooling water flow rates and liquid to gas ratio to be monitored and amend these depending on the seasonal variations and design values. For example: increase water loads during higher cooling load and times when approach is

high and increase air flow during low cooling load times and when approach is low.

16. COC improvement measures to be considered for water savings
17. Fiber reinforced, Energy efficient plastic blade is considered acceptance for fan energy savings.
18. Cooling tower fans based on leaving water temperatures to be controlled especially in small units
19. Cooling water pumps to be checked frequently to increase their efficiency

Note: A 1°C cooling water temperature increase may increase the A/C compressor electricity consumption by 2.7%. A 1°C drop in cooling water temperature can give a heat rate saving of 5 kCal/kWh in a thermal power plant

2.3.14. Governing factors of operation of cooling tower

- Warm water temperature
- Wet-bulb and dry-bulb and temperatures of the air
- Efficiency of heat transfer from water to air.
- The consistency of spreading of the segments within the tower
- Pressure drop of air
- The desired Cooled water temperature.

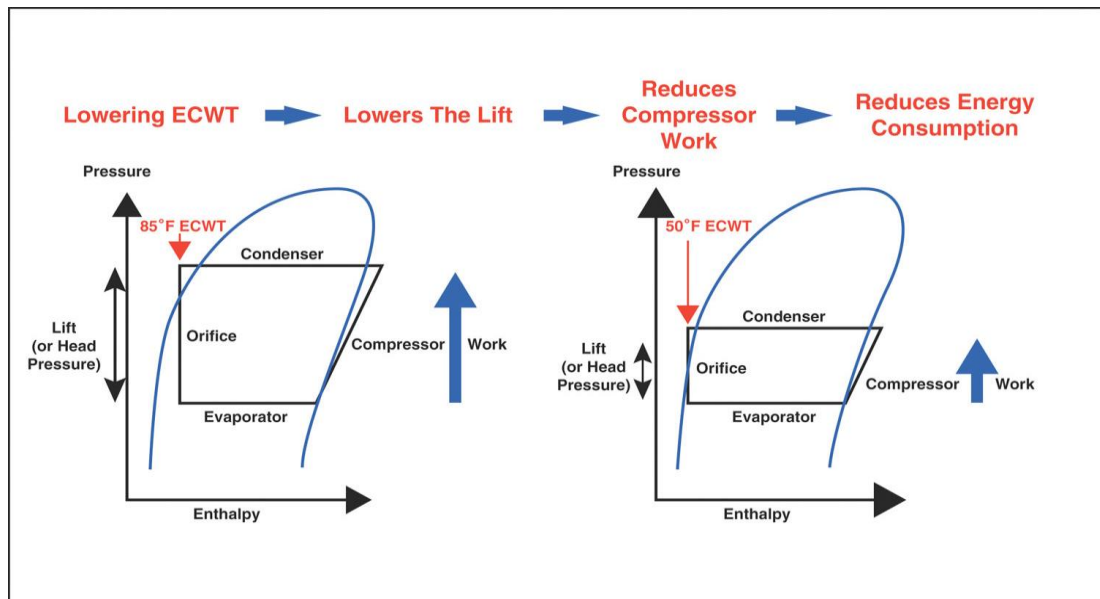

Figure 21 : For refrigerating machines in HVAC systems, reducing the condensing temperature leads to lower energy consumption [19]

Though cooling towers can be operated at higher humidity, most of the time evaporation of water gain the cooling effect. Water evaporation is nearly 1% of the process and treated make-up water to be supplied to the tower. When the evaporation is increased the concentration of dissolved solid and other substance will be increased. Inefficiency of cooling towers cause energy losses at the compressor and chiller. Water in the tower should be maintained properly otherwise temperature might be 10°C higher than the design temperature. It will cost up to 3.5% extra energy.

Air and water in terms of the volumetric mass transfer coefficient and the contact time between the air and the water

- i. The uniformity of distribution of the phases within the tower
- ii. The air pressure drop
- iii. The desired temperature of the cooled water

2.3.15. Achieving Energy Efficiency

In terms of energy efficiency, having variable speed drives for cooling tower fan motors, which are operating 24 hrs, seems very economical. During part load

operation, especially in the night time, fan speed could be reduced to achieve energy savings without affecting the cooling capacity.

Reducing drift loss could lead to decrease the makeup water requirement and also it reduces the potential hazard of Legionnaires' Disease. It has been seen that the Cross Flow cooling towers are significantly better in terms of low water losses. When less makeup water is used, the cost for chemical cleaning and the cost for makeup water will also be reduced. Since cross-flow type cooling towers has low solar penetration to the sump, algae build up is reduced, thus cost for chemical treatment is low.

2.3.16. Water vs. Air Cooled Systems [20]

- i. Reduction in compressor power due to lower condensing temperatures
- ii. 1.5 to 3 times greater COP than air cooled
- iii. 30 to 50% potential energy savings
- iv. By far the largest opportunity to reduce energy usage

2.3.17. Cooling tower ratings

Cooling tower air rating by CTI (Cooling Technology Institute)

Data used in (US Conditions)

Table 2: Tower Data in US Condition

Tower entering	35 ⁰ C	Range 5 K
Tower leaving	29.5 ⁰ C	Approach 5 K
Entering air wet bulb temperature		24 ⁰ C WB

Data of CTs are operated at local conditions

Table 3: Tower Data in Local Condition

Tower entering	37 ⁰ C	Range 5 K
Tower leaving	32 ⁰ C	Approach 5 K
Entering air wet bulb temperature		27 ⁰ C WB

Cooling tower operating parameters at local conditions are 27 CWB, 37C/32C entering & leaving water temperatures respectively. However, most of the chillers are rated at condenser entering & leaving at 24 CWB, 30C/35C entering & leaving water temperatures respectively, which is AHRI conditions USA. Due to this reason, chillers will operate at reduced efficiency and wasting energy than designed for.

In order to mitigate this deficiency, cooling tower capacity should be increased or add more cooling towers to match the CTI certified tower water flow rates. In practice this would be 3 sizes higher than the normal selection, which could have attained AHRI conditions.

Example 1:

If the tower FC – 150, (150TR).

We need to select FC – 250, (250TR), which satisfy the US condition

However, increasing the CT capacity does not increase the power consumption that much.

Example 2:

FC – 150 tower Fan Horse Power 3.7kW

FC – 250 tower Fan Horse Power 7.5kW

- Most of the commercial and government high rise buildings are air conditioned by using water cool multiple chiller system.
- Always one stand by chiller is sleeping with one cooling tower on the rooftop.

- Operators may not have an idea to use idle cooling tower to reduce the condenser water temperature or they may think it's not economical.
- Our data collection is targeted to prove, the usage of idling cooling towers with variable speed drive is economical. Running of VFDs in low frequency levels is reduced the power consumption.

Chapter-3

Data Collection & Analysis

Selection of suitable places for collection of data were based on the availability of combined cooling tower system, Multiple Chillers and Air condition system monitoring process. Then World Trade Center (WTC) Building in Colombo was selected and with the approval of relevant authorities' data collection was carried out for three months. It was not a continuous process.

Collected data were analyzed and based on the results the conclusions have been made.

3.1. Data Collection

3.1.1. Design for Data collection

The cooling towers under study are CTI certified towers and AHRI conditions satisfied. Multiple Cooling Tower Combination and Chiller combination with the changing of cooling tower fan motor speed were used to collect multiple data.

Table 4 : Colombo Three Hourly Wet Bulb Temperature - 2018

Colombo three hourly wet bulb temperature – 2018 (meteorological department data)						Daily Average
05.30	08.30	11.30	14.30	17.30	20.30	
17.8	18.8	20.0	22.4	23.0	22.4	20.73
23.8	24.8	25.5	26.5	25.2	24.8	25.10
20.4	21.8	23.0	23.8	23.3	23.8	22.68
21.5	22.8	24.4	24.3	23.6	22.6	23.20
24.0	24.8	25.6	25.8	25.3	24.2	24.95
22.8	22.6	24.2	24.9	26.1	25.0	24.27
20.4	21.6	24.1	23.8	23.5	23.3	22.78
23.2	24.2	25.4	24.7	26.3	22.4	24.37
24.0	24.3	25.1	25.4	24.3	24.6	24.62
23.8	24.8	25.2	24.8	24.0	24.6	24.53
25.3	26.2	26.2	26.6	26.0	25.6	25.98
24.2	25.2	27.0	26.8	26.7	26.2	26.02
23.6	25.7	26.4	26.2	23.4	23.9	24.87
23.6	25.0	26.6	26.4	26.2	25.0	25.47
24.8	26.2	27.0	27.6	26.8	25.4	26.30
25.0	26.2	26.8	27.6	27.2	24.0	26.13
25.7	25.4	26.8	26.8	26.6	26.0	26.22
25.4	26.6	26.6	26.6	26.8	25.2	26.20
25.3	26.2	26.2	26.0	25.1	25.2	25.67
26.0	26.7	27.3	26.8	26.0	26.4	26.53
25.6	25.6	26.4	25.6	24.6	25.8	25.60
25.6	25.8	26.0	26.6	26.1	26.0	26.02
24.6	25.8	26.6	26.6	26.1	25.4	25.85

25.0	26.4	26.2	26.8	26.6	25.8	26.13
25.0	25.2	25.6	25.8	25.6	25.6	25.47
25.6	25.8	26.4	26.3	25.6	25.8	25.92
25.0	25.4	26.0	25.8	25.4	25.4	25.50
24.8	25.2	25.8	25.4	25.0	25.2	25.23
25.0	25.6	25.3	25.8	25.3	24.6	25.27
25.6	25.9	25.7	26.7	26.3	24.7	25.82
24.8	25.2	25.6	25.4	25.1	24.6	25.12
24.2	25.0	24.8	25.0	24.6	24.8	24.73
24.8	25.0	25.4	25.4	25.0	24.6	25.03
24.6	25.1	25.8	25.2	24.3	24.4	24.90
25.2	26.4	24.2	26.0	26.0	24.6	25.40
24.6	25.3	25.3	25.8	25.1	25.0	25.18
23.9	24.9	24.2	25.0	25.6	25.5	24.85
23.5	25.0	25.6	26.2	25.2	25.2	25.12
23.3	24.6	25.4	26.0	25.2	25.3	24.97
23.9	25.2	26.2	26.4	24.3	24.6	25.10
23.0	23.7	25.6	26.2	25.2	24.2	24.65
23.5	25.2	26.2	26.2	26.0	25.8	25.48
24.3	25.1	25.3	25.7	24.8	24.8	25.00

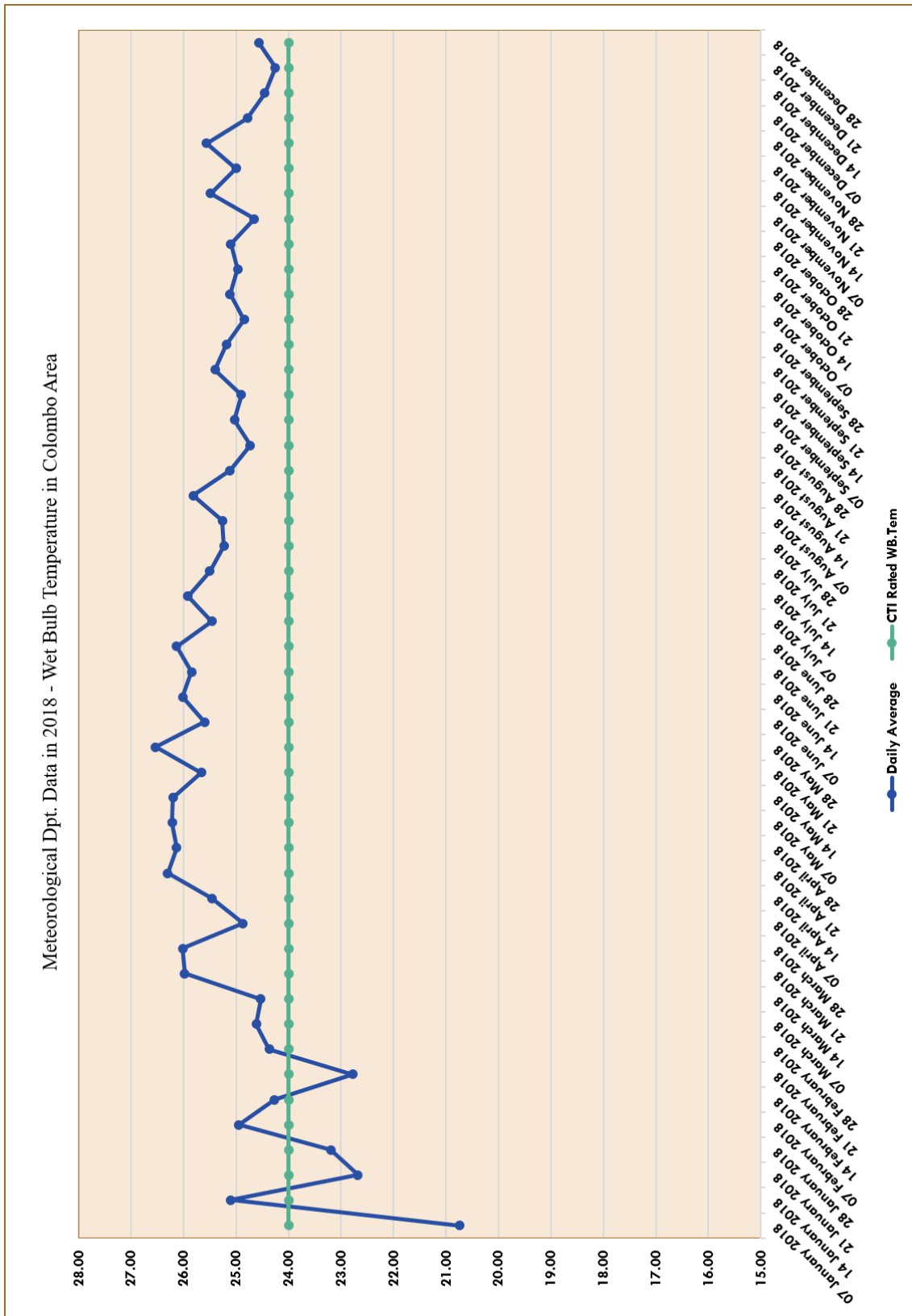

Chart 1 : Wet Bulb Temperature in Colombo Area

- Chart No 01 shows Colombo area Wet Bulb Temperature in 2018 collected from Meteorological department.
- It shows Wet Bulb Temperature(WBT) is closer or lower to CTI rated WBT (24°C) for less than three months in the year.
- CT operating parameters and CTI certified parameters are not match for nine months.
- Even though, the wet bulb temperatures in Sri Lanka, are above the certified level, chiller plants should be operated on certified conditions to achieve the certified efficiency.

Design criteria of a cooling tower Approach is said,

- The size of a cooling tower depends on the flow, water inlet and outlet temperatures and the design wet bulb temperature.
- The smaller the Approach, the larger the size of the tower.
- Economical selections are based on selections using an approach of 4°C .
- Selections using an approach smaller than 2.3°C are not economical, nor will be certified by CTI.
- Selections using Approaches more than 4°C result in higher condensing temperatures (reduced chiller efficiency and performance) without much savings on the cooling tower.

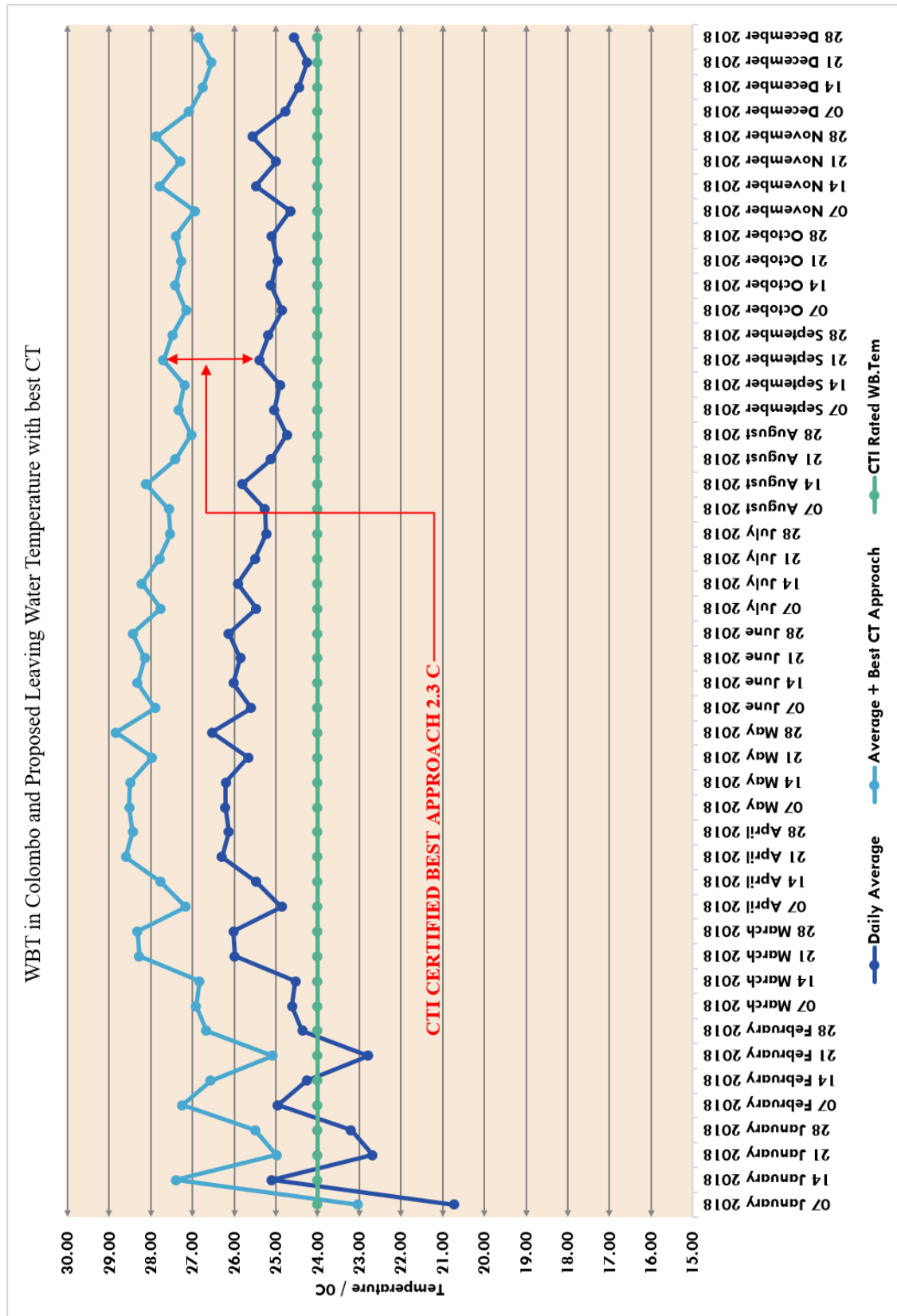

Chart 2 : WBT in Colombo and Proposed Leaving Water Temperature with best CT

Colombo area WBT and Best CT leaving water temperature

- CTI cooling tower certification for evaporative heat rejection is declared the best approach as 2.3°C in the latest publication. CTI STD 201 is the standard for thermal performance certification of evaporative heat rejection equipment.
- WBT + 2.3 (The best Approach) are plotted on Chart No. 02.
- Chart No. 02 shows, best possible Approach **in normal configuration** and shows, it's not possible to reach to certified levels **in normal configuration**.
- **Improved cooling tower configuration** is required to achieve the certified efficiency levels or better.

3.1.2. Limitations

- Maintaining of constant Evaporator Leaving Water Temperature was not possible, because WTC is a large commercial building
- There was not possibility to use 1125TR ($900 \times 1.25 = 1125$) CT to get COP at Normal Configuration.

3.1.3. Considerations

- Chiller was operated on full load condition
- Constant flow rate of condenser water was maintained

3.1.4. Details of Plant and Machinery used for Data Collection

Table 5 : Plant and Equipment

Chiller Plant	
Make	TRANE
Modal	CVGF 1000
Capacity	900 TR
Design Parameters	
Evaporator Lev./Ent. Temperature / $^{\circ}\text{C}$	7/12.5
Condenser Ent./Lea. Temperature / $^{\circ}\text{C}$	29.5/35.5
Efficiency :100%	0.54 kW/TR

Cooling Tower (CT)	
Make	Mesan
Modal	MXL-04D-30
Type	Cross flow
Capacity	2832kW (800TR)
Driven By	VFD
Design Parameters	
Approach / °C	3
Range / °C	5.5
Wet Bulb Temperature	28
CT Ent./Lea. Temperature / °C	36.5/31
Number of CTs.	2
Water flow rate	123 L/s

3.1.5. Data Collection (WTC) – Stage 1

Table 6 : Cooling Tower Data

Cooling tower		R 1	R 2	R3	R 4	R 5
Number of Tower in Operation		2	3	3	5	5
	CT1	800	800	800	800	800
	CT2	800	800	800	800	800
Capacity of Towers/TR	CT3		850	850	850	850
	CT4	-	-	-	850	850
	CT5	-	-	-	850	850
	CT1	45	40	45	40	45
	CT2	45	40	45	40	45
FAN Speed/ Hz	CT3		40	45	40	45
	CT4	-	-	-	40	45
	CT5	-	-	-	40	45
	CT1	23.7	17.7	23.2	17.7	24.5
	CT2	21.5	15.8	22.2	15.9	22.8
Current Drawn by CT/ A	CT3	0	18.0	17.2	17.6	25.7
	CT4	0	0	0	19.4	28.0
	CT5	0	0	0	13.3	17.9
CT Leaving Water Temperature		30.6	29.2	28.9	28.7	28.3
CT Entering Water Temperature		37.4	36.0	36.5	36.5	36.1
Condenser Water Pump		2-35 Hz	2-35 Hz	2-35 Hz	2-35 Hz	2-35 Hz

Table 7 : Chiller Data

Chiller		R 1	R 2	R3	R 4	R 5
Operation Condition		Full Load	Full Load	Full Load	Full Load	Full Load
Chiller Evaporator	Leaving Water Temperature	11.6	13.9	13.1	12.9	12.4
	Entering Water Temperature	16.5	18.8	18.7	18.7	18.1
Chiller Condenser	Leaving Water Temperature	37.4	36	36.5	36.5	36.1
	Entering Water Temperature	30.6	29.2	28.8	28.7	28.3
Chilled Water Flow Rate / It/s		192	192	166	163	166
Power Analyser Reading	Current L1,L2,L3/ A	889/899 /886	874/893 /875	858/880 /865	875/884 /869	870/885 /864
RH (Colombo Met. Dep. Area)		57	57	44	69	69
WB Temp. (Colombo Met. Dep. Area)		25.8	25.8	26.0	25.8	25.8
Site WB Temp.(Cooling Tower Area)		24.2	24.3	24.4	24.5	23.9
BMS Reading		R 1	R 2	R3	R 4	R 5
Efficiency kW/ Ton		0.48	0.47	0.47	0.49	0.49
Capacity TR		1144	1150	1173	1118	1138
Ambient Temperature / °C		30.8	31	33.9	29	28.4
Building Cooling Load / TR		1144	1150	1173	1118	1138

3.1.5.1. Calculation

3.1.5.1.1. Cooling Load Calculation of Chiller

Considering Specific Heat Formula,

Heat Energy = (Mass Of Substance) (Specific Heat) (Change In Temperature)

$$Q = M C_p \Delta T$$

- Q - Heat Energy (Joules, J)
- M - Mass of a Substance (Kg)
- C_p - Specific Heat (Units J/Kg·K)
- Δ Is a Symbol Meaning "The Change In"
- ΔT - Change in Temperature (Kelvins, K)

3.1.5.1.2. Power Consumption of Chiller

$$W = V. I. Pf. (1.73)$$

- W - power consumption (kw)
- I - current (A)
- PF - power factor
- 1.73 - constant for 3phase supply

3.1.5.1.3. Three phase power calculation (VFD driven)

$$\text{Power (kW)} = \text{voltage} \times \text{current} \times \text{power factor} \times 1.73$$

Table 8 : Cooling Tower Data & Calculations

Cooling tower		R 1	R 2	R3	R 4	R 5
Number of Tower in Operation		2	3	3	5	5
Capacity of Towers/TR	CT1	800	800	800	800	800
	CT2	800	800	800	800	800
	CT3		850	850	850	850
	CT4	-	-	-	850	850
	CT5	-	-	-	850	850
FAN Speed/ Hz	CT1	45	40	45	40	45
	CT2	45	40	45	40	45
	CT3		40	45	40	45
	CT4	-	-	-	40	45
	CT5	-	-	-	40	45
Current Drawn by CTs (with VFD) / A	CT1	23.7	17.7	23.2	17.7	24.5
	CT2	21.5	15.8	22.2	15.9	22.8
	CT3	0	18	17.2	17.6	25.7
	CT4	0	0	0	19.4	28
	CT5	0	0	0	13.3	17.9
CT Leaving Water Temperature / °C	$T_{CT(Lea)}$	30.6	29.2	28.9	28.7	28.3
CT Entering Water Temperature / °C	$T_{CT(Ent)}$	37.4	36	36.5	36.5	36.1
$T_{CT(Ent - Lea)} / °C$		6.8	6.8	7.6	7.8	7.8
Total Current drawn by CTs /A		45.2	51.5	62.6	83.9	118.9
Total Power Consumed by CTs /kW		25.0	28.5	34.7	46.4	65.8
Cost in Rs. (with VFD) - @19.20 Rs/kWhr		659.01	1,008.70	1,008.70	1,667.71	1,667.71

Table 9 : Chiller Data & Calculations

Chiller		R 1	R 2	R3	R 4	R 5
Operation Condition		Full Load	Full Load	Full Load	Full Load	Full Load
Chiller Evaporator	Leaving Water Temperature / ⁰ C	11.6	13.9	13.1	12.9	12.4
	Entering Water Temperature / ⁰ C	16.5	18.8	18.7	18.7	18.1
Chiller Condenser	Leaving Water Temperature / ⁰ C	37.4	36	36.5	36.5	36.1
	Entering Water Temperature / ⁰ C	30.6	29.2	28.8	28.7	28.3
Chilled Water Flow Rate / Lt/s		192	192	166	163	166
Power Analyzer Reading /A	Current, L1, L2, L3/ A	889/ 899/ 886	874/ 893/ 875	858/ 880/ 865	875/ 884/ 869	870/ 885/ 864
CT Leaving Water Temperature / ⁰ C		30.6	29.2	28.9	28.7	28.3
CT Entering Water Temperature / ⁰ C		37.4	36	36.5	36.5	36.1
RH (Colombo Met. Dep. Area) / %		57	57	44	69	69
WB Temp. (Colombo Met. Dep. Area) / ⁰ C		25.8	25.8	26	25.8	25.8
BMS Reading		R 1	R 2	R3	R 4	R 5
Efficiency kW/ TR		0.48	0.47	0.47	0.49	0.49
Capacity TR		1144	1150	1173	1118	1138
Ambient Temperature / °C		30.8	31	33.9	29	28.4
Building Cooling Load / TR		1144	1150	1173	1118	1138
Calculated Chiller Power /kW		542.79	536.29	528.37	533.45	531.62
Site WB Temp. (Cooling Tower Area) /⁰C		24.2	24.3	24.4	24.5	23.9
CT Leaving - Site WB Temp. /⁰C		6.4	4.9	4.5	4.2	4.4

Approach (with Met. Dep. WB) /°C		4.8	3.4	2.9	2.9	2.5
Approach (with Site WB) /°C		6.4	4.9	4.5	4.2	4.4
Cooling Load of Chiller/ TR		1123.50	1123.50	1110.13	1129.00	1129.95
Chiller Efficiency / kW/TR		0.483	0.477	0.476	0.472	0.470
COP /(kW/kW)		7.28	7.37	7.39	7.44	7.48
Chiller Power consumption(Ave . full load 1123TR)/kW		542.5	536.1	534.5	530.6	528.4
Chiller Power consumption (A.F.L.) - 19.20 Rs/kWhr		10,417	10,292	10,262	10,188	10,144

3.1.5.1.4. Calculated Figures

Table 10 :Calculated Figures

T CT(Ent - Lea) / $^{\circ}$ C	6.8	6.8	7.6	7.8	7.8
Total Current drawn by CTs /A	45.2	51.5	62.6	83.9	118.9
Total Power Consumed by CTs /kW	14.464	16.48	20.032	26.848	38.048
CT Cost in Rs. (with VFD) - @19.20 Rs/kWhr	659.01	1,008.70	1,008.70	1,667.71	1,667.71
Calculated Chiller Power /kW	542.79	536.29	528.37	533.45	531.62
Site WB Temp. (Cooling Tower Area)/ $^{\circ}$ C	24.2	24.3	24.4	24.5	23.9
CT Leaving - Site WB Temp. / $^{\circ}$ C	6.4	4.9	4.5	4.2	4.4
Approach (with Met. Dep. WB) / $^{\circ}$ C	4.8	3.4	2.9	2.9	2.5
Approach (with Site WB) / $^{\circ}$ C	6.4	4.9	4.5	4.2	4.4
Cooling Load of Chiller/ TR	1123.50	1123.50	1110.13	1129.00	1129.95
Chiller Efficiency / kW/TR	0.4831	0.4773	0.4760	0.4725	0.4705
COP / (kW /kW)	7.28	7.37	7.39	7.44	7.48
Chiller Power consumption(Ave. full load 1123TR)/kW	542.5	536.1	534.5	530.6	528.4
Chiller Power Cost (A.F.L.) - 19.20 Rs/kWhr	10,416.8	10,292.2	10,262.4	10,187.8	10,144.3
Total cost of Power/ Rs./kWhr.	10,897.27	10,839.57	10,927.80	11,079.60	11,408.15

3.1.5.2. Analysis

Approach (with Site WB)

Table 11 : Cooling tower combination Vs Approach

Cooling Tower Combination	Approach (with Site WB)
R 1	6.4
R 2	4.9
R3	4.5
R 4	4.2
R 5	4.4



Chart 3 : Approach (With site WB)

Total Power Consumed by CTs /kW'

Table 12 : Cooling tower combination Vs Total power consumed by CTs/kW

Cooling Tower Combination	Total Power Consumed by CTs /kW
R 1	25.02
R 2	28.51
R3	34.66
R 4	46.45
R 5	65.82

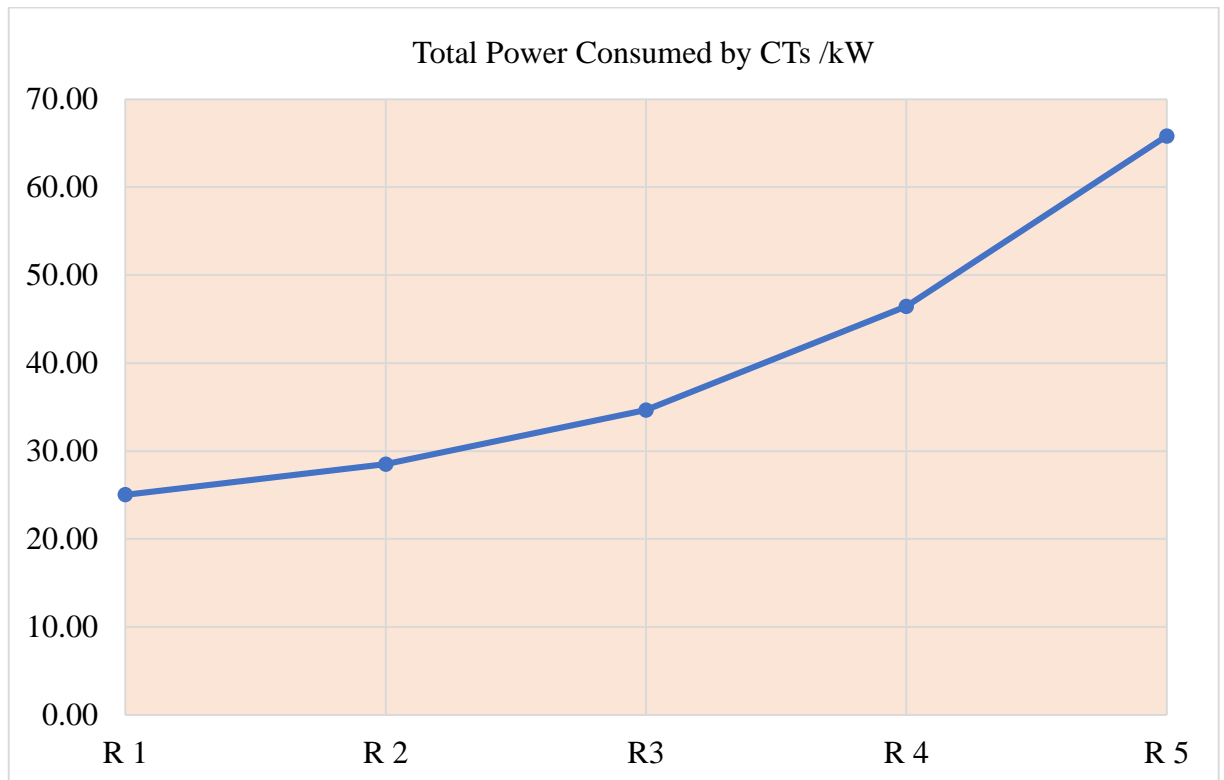

Chart 4 : Total power consumed by CTs/kW

Coefficient Of Performance (COP)

Table 13 : CT combination Vs COP

Cooling tower combination	COP
R 1	7.280
R 2	7.368
R3	7.389
R 4	7.443
R 5	7.475

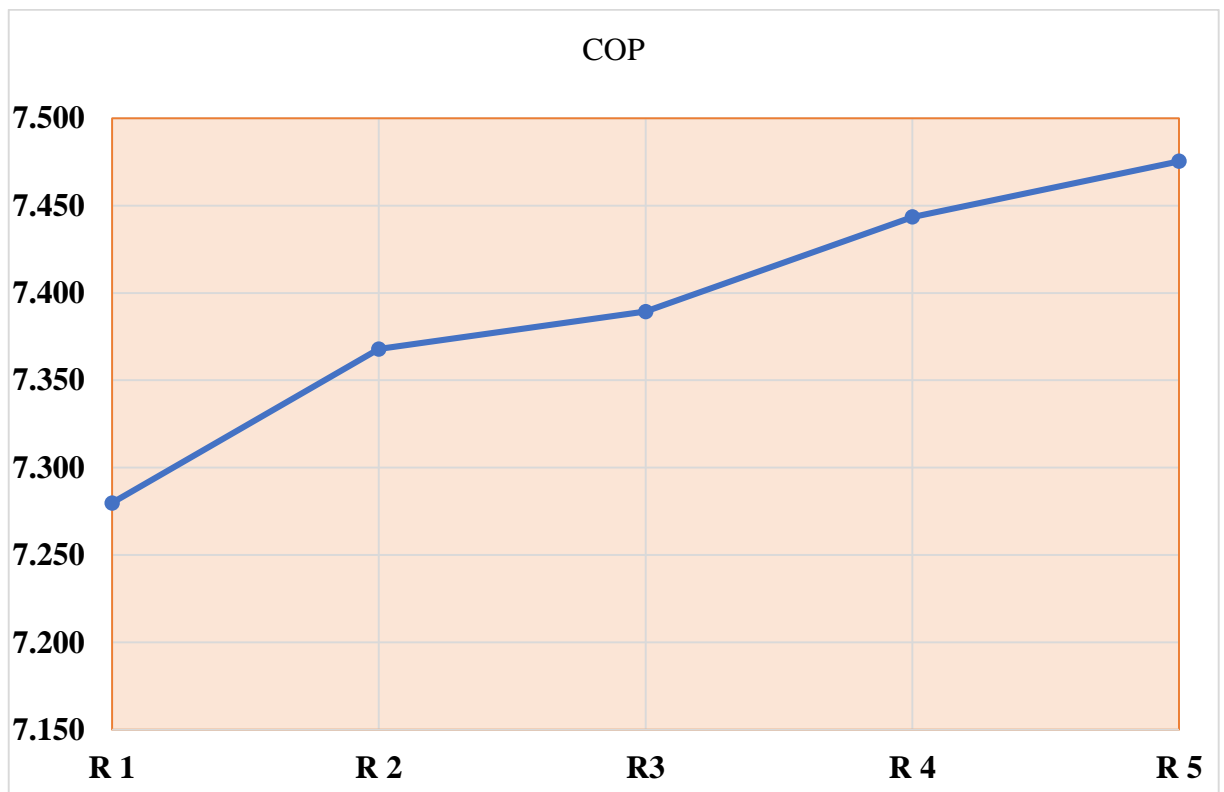

Chart 5 : COP

3.1.5.3. Mathematical Analysis

Table 14 : Comparison of the cost electrical power of each combination

Cooling Tower Combination	Cooling Tower Power Cost in Rs. (with VFD) - @19.20 Rs/kWhr	Chiller Power Cost in Rs. (Ave. F.L.) - @19.20 Rs/kWhr	Total Cost - Rs/kWhr
R 1	480.44	10,416.83	10,897.27
R 2	547.40	10,292.17	10,839.57
R 3	665.38	10,262.42	10,927.80
R 4	891.78	10,187.82	11,079.60
R 5	1,263.80	10,144.35	11,408.15

Lowest cost incurred on R2 combination. Therefore, R2 cooling tower combination can be selected as the best of these combination.

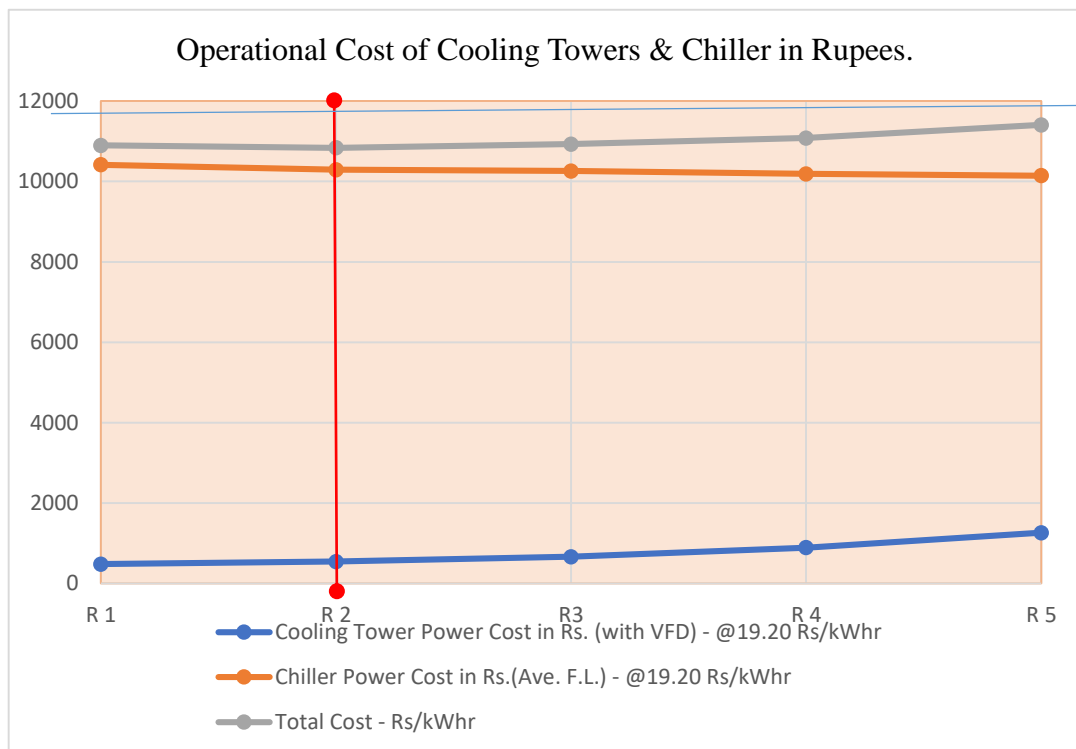
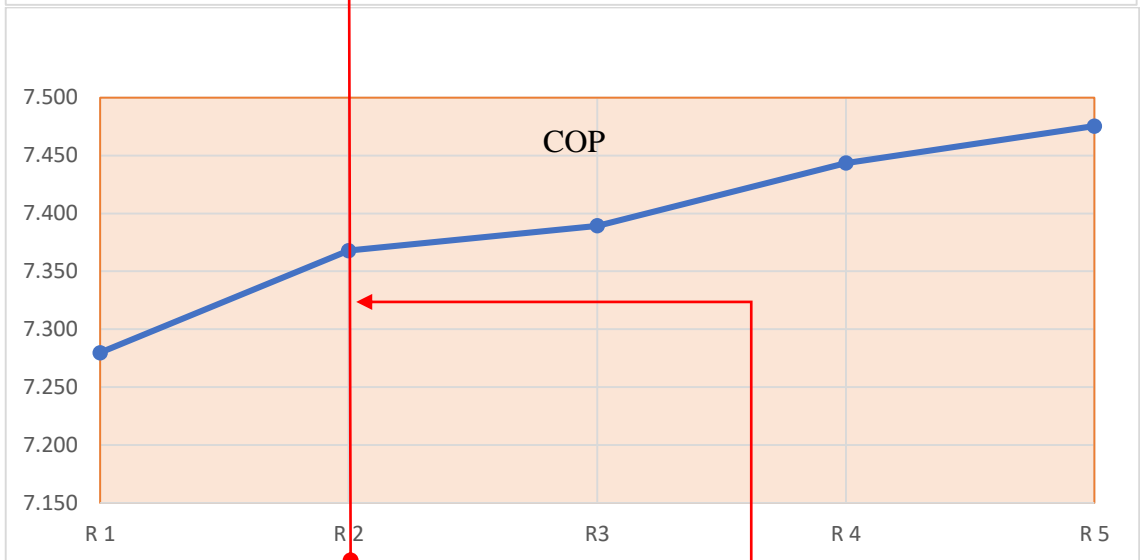
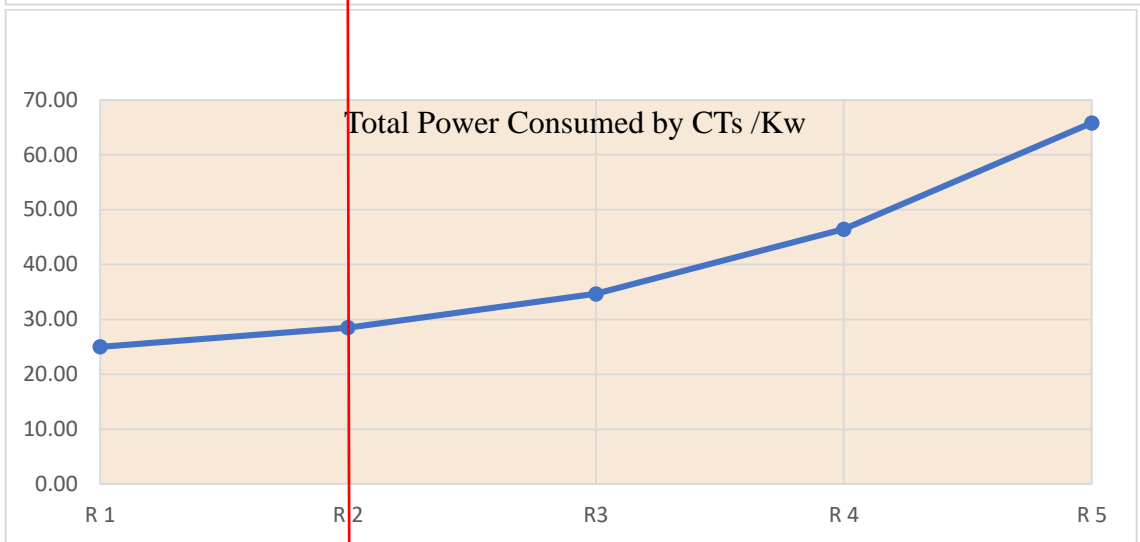

Chart 6 : Operational Cost of Cooling Towers & Chillers in Rupees



R2 combination seems as better configuration
 That mean three cooling tower configuration is better.

3.1.5.4. Observation of Stage 1:

At stage 1, cooling towers were arranged in five different combinations and collected data at each combination separately. Variation of chiller efficiency, improvement of Approach and effect of power cost were calculated. There was a pattern of changing of the properties and factors. Therefore, we were able to find most economical combination of cooling towers as R2. Three Cooling Towers which have 800, 800 & 850TR capacities, were combined to the common header and collect the data in this R2 combination. Therefore, this R2 combination was used for next stage.

3.1.6. Data Collection (WTC) – Stage 2

Continuation of the research to find optimum fan speeds to get better performance of Cooling Towers was the purpose of Stage 2. We observed that Three Cooling Tower combination is the better combination. Therefore, collection of data by vary the fan speeds from 40Hz to 50Hz was the methodology of Stage 2

Table 15 : Cooling Tower Data

COOLING TOWER		R 6	R 7	R 8	R 9	R 10	R 11	R 12	R 13	R 14	R 15	
Number of Tower in Operation		3	3	3	3	3	3	3	3	3	3	
	CT1	800	800	800	800	800	800	800	800	800	800	
	CT2	800	800	800	800	800	800	800	800	800	800	
Capacity of Towers/TR		CT3	850	850	850	850	850	850	850	850	850	
	CT4	-	-	-	-	-	-	-	-	-	-	
	CT5	-	-	-	-	-	-	-	-	-	-	
	CT1	40	40	40	41	42	43	44	45	45	50	
	CT2	40	40	40	41	42	43	44	45	45	50	
FAN Speed/ Hz		CT3	40	40	40	41	42	43	44	45	50	
	CT4	-	-	-	-	-	-	-	-	-	-	
	CT5	-	-	-	-	-	-	-	-	-	-	
	CT1	17.5	17.7	16.5	17.3	18.7	20.2	21.8	23.2	24.9	32.3	
	CT2	15.5	15.8	15.7	16.3	18	19.1	20.9	22.2	22.6	29.7	
Current Drawn by CT/ A		CT3	17.1	18	16.7	17.4	18.9	20.1	19.1	17.2	25	32.9
	CT4	0	0	0	0	0	0	0	0	0	0	
	CT5	0	0	0	0	0	0	0	0	0	0	
CT Leaving Water Temperature		29.1	29.2	32.3	31.7	31.7	31.5	28.9	28.8	28.5	28.5	
CT Entering Water Temperature		35.5	36	37	36.2	37.5	37.6	36.0	36.5	36	34.9	
Condenser Water Pump		2-35 Hz	2-35 Hz	2-35 Hz	2-35 Hz	2-35 Hz	2-35 Hz	2-35 Hz	2-35 Hz	2-35 Hz	2-35 Hz	

Table 16 : Chiller Data

CHILLER		R 6	R 7	R 8	R 9	R 10	R 11	R 12	R 13	R 14	R 15
Operation Condition		Full Load	Full Load	Full Load	Full Load	Full Load	Full Load	Full Load	Full Load	Full Load	Full Load
Chiller Evaporator	Leaving Water Temp.	11.6	13.9	11.2	11	10.9	10.9	10.9	12.8	10.6	8.2
	Entering Water Temp.	17.5	18.8	17.1	16.9	16.9	16.9	16.9	18.7	16.7	14.3
Chiller Condenser	Leaving Water Temp.	35.5	36	37	36.2	37.5	37.6	36	36.5	36	34.9
	Entering Water Temp.	29.1	29.2	32.3	31.7	31.7	31.5	28.9	28.8	28.1	28.5
Chilled Water Flow Rate / It/s		161	192	164	164	160	164	163.9	166	161	161
Power Analyser Reading	Current, L1, L2, L3/ A	890/896/885	874/893/875	885/892/882	885/894/880	858/883/871	866/883/871	861	850/865/858	860	855
RH (Colombo Met. Dep. Area)		52	57	56	56	56	56	45	44	49	47
WB Temp. (Colombo Met. Dep. Area)		26.4	25.8	25.2	25.2	25.2	25.2	24.8	26	25.8	25.8
Site WB Temp. (Cooling Tower Area).		23.3	24.3	26.9	26.9	26.9	26.8	24.7	24.4	24.2	24.3
BMS Reading		R 6	R 7	R 8	R 9	R 10	R 11	R 12	R 13	R 14	R 15
Efficiency kW/Ton		0.5	0.47	0.5	0.49	0.49	0.46	0.47	0.47	0.48	0.48
Capacity TR		1080	1150	1163	1162	1125	1147	1160	1125	1135	1100
Ambient Temperature / °C		30.8	31	33.9	33.9	33.9	33.8	34.1	33.9	32.5	33
Building Cooling Load / TR		1080	1150	1163	1163	1125	1147	1160	1125	1135	1100

3.1.6.1. Calculation

Table 17 : Cooling Tower Data & Calculations

COOLING TOWER	R 6	R 7	R 8	R 9	R 10	R 11	R 12	R 13	R 14	R 15	
Number of Tower in Operation	3	3	3	3	3	3	3	3	3	3	
Capacity of Towers/TR	CT1	800	800	800	800	800	800	800	800	800	
	CT2	800	800	800	800	800	800	800	800	800	
	CT3	850	850	850	850	850	850	850	850	850	
FAN Speed/Hz	CT1	40	40	40	41	42	43	44	45	45	50
	CT2	40	40	40	41	42	43	44	45	45	50
	CT3	40	40	40	41	42	43	44	45	45	50
Current Drawn by CT/ A	CT1	17.5	17.7	16.5	17.3	18.7	20.2	21.8	23.2	24.9	32.3
	CT2	15.5	15.8	15.7	16.3	18	19.1	20.9	22.2	22.6	29.7
	CT3	17.1	18	16.7	17.4	18.9	20.1	19.1	17.2	25	32.9
CT Leaving Water Temperature		29.1	29.2	32.3	31.7	31.7	31.5	28.9	28.8	28.5	28.5
CT Entering Water Temperature		35.5	36	37	36.2	37.5	37.6	36.0	36.5	36	34.9
T_{CT(Ent - Lea)}		6.4	6.8	4.7	4.5	5.8	6.1	7.1	7.7	7.5	6.4
Total Current drawn by CT		50.1	51.5	48.9	51	55.6	59.4	61.8	62.6	72.5	94.9
Total Power Consumed by CTs		16.0	16.5	15.6	16.3	17.8	19.0	19.8	20.0	23.2	30.4
Cost in Rs. (with VFD) - @19.20 Rs/kWhr		533	547	520	542	591	631	657	665	771	1,008

Table 18 : Chiller Data & Calculations

CHILLER		R 6	R 7	R 8	R 9	R 10	R 11	R 12	R 13	R 14	R 15
Operation Condition		Full Load	Full Load	Full Load	Full Load	Full Load	Full Load	Full Load	Full Load	Full Load	Full Load
Chiller Evaporator	Leaving W.T.	11.6	13.9	11.2	11	10.9	10.9	10.9	12.8	10.6	8.2
	Entering W.T.	17.5	18.8	17.1	16.9	16.9	16.9	16.9	18.7	16.7	14.3
Chiller Condenser	Leaving W.T.	35.5	36	37	36.2	37.5	37.6	36.0	36.5	36	34.9
	Entering W.T.	29.1	29.2	32.3	31.7	31.7	31.5	28.9	28.8	28.1	28.5
Chilled Water Flow Rate / It/s		161	192	164	164	160	164	163.9	166	161	161
Power Analyser Reading	Current,L1,L2, L3/A	890/896/885	874/893/875	885/892/882	885/894/880	858/883/871	866/883/871	861	850/865/858	860	855
RH - Colombo Met. Dep. Area		52	57	56	56	56	56	45	44	49	47
WB Temp. (Colombo Met. Dep. Area)		26.4	25.8	25.2	25.2	25.2	25.2	24.8	26	25.8	25.8
Site WB Temp. (Cooling Tower Area)		23.3	24.3	26.9	26.9	26.9	26.8	24.7	24.4	24.2	24.3
BMS Reading		R 6	R 7	R 8	R 9	R 10	R 11	R 12	R 13	R 14	R 15
Efficiency kW/ Ton		0.5	0.47	0.5	0.49	0.49	0.46	0.47	0.47	0.48	0.48
Capacity TR		1080	1150	1163	1162	1125	1147	1160	1125	1135	1100
Ambient Temperature / °C		30.8	31	33.9	33.9	33.9	33.8	34.1	33.9	32.5	33.0
Building Cooling Load / TR		1080	1150	1163	1163	1125	1147	1160	1125	1135	1100
Approach (T_{CT(Lea - Wet)})		5.8	4.9	5.4	4.8	4.8	4.7	4.2	4.4	4.3	4.2
Calculated Power -Chiller/ kW		542	536	540	540	530	532	524	522	524	522
Calculated Cooling Load of Chiller / TR		1134	1124	1156	1156	1146	1175	1174	1170	1173	1173
Chiller Efficiency / kW/TR		0.478	0.477	0.467	0.467	0.462	0.453	0.446	0.447	0.447	0.445

COP		7.36	7.37	7.53	7.53	7.60	7.77	7.88	7.88	7.88	7.90
Chiller Power consumption(Ave. full load 1123TR)/kW		536.7	536.	524.6	524.6	519.4	508.2	501.4	501.5	501.5	499.7
Chiller Power consumption (A.F.L.) - 19.20 Rs/kWhr		10,305.46	10,292.17	10,071.50	10,071.50	9,971.80	9,758.38	9,626.44	9,628.34	9,627.99	9,594.40
Total Cost - Rs/kWhr		10,837.98	10,839.57	10,591.26	10,613.58	10,562.78	10,389.75	10,283.32	10,293.72	10,398.60	10,603.11

3.1.6.2. Analysis

Table 19 : Cooling tower fan speed Vs Approach (T_{CT(Lea - Wet)})

Cooling tower fan speed	Approach (T _{CT(Lea - Wet)})
R 6	5.8
R 7	4.9
R 8	5.4
R 9	4.8
R 10	4.8
R 11	4.7
R 12	4.2
R 13	4.4
R 14	4.3
R 15	4.2

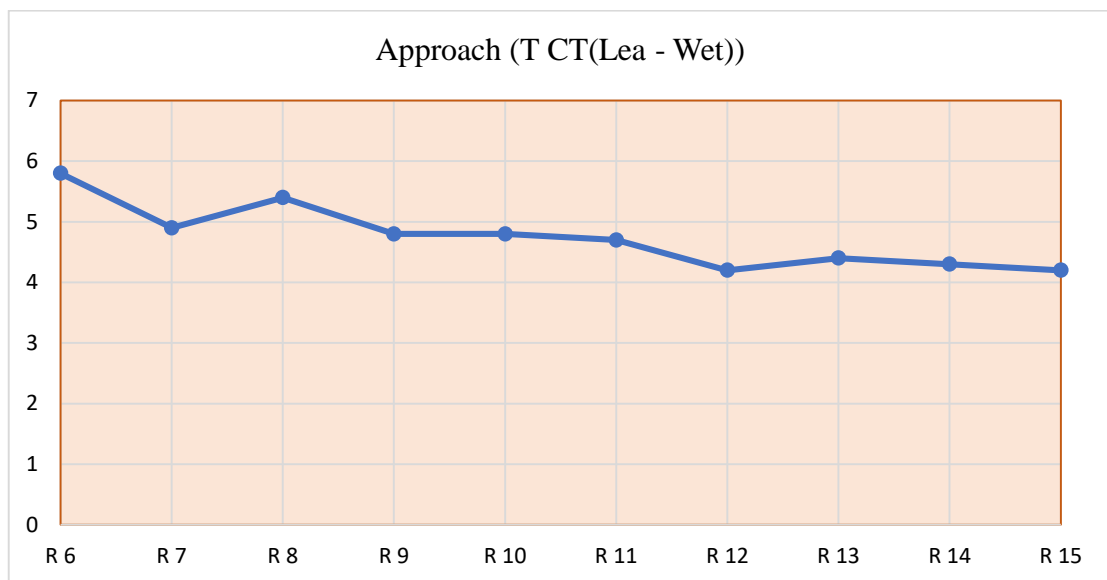

Chart 7 : Approach (T_{CT(Lea - Wet)})

Table 20 : Cooling tower fan speed Vs Total Power Consumed by CTs /kw

Cooling tower fan speed	Total Power Consumed by cts /kw
R 6	27.74
R 7	28.51
R 8	27.07
R 9	28.23
R 10	30.78
R 11	32.88
R 12	34.21
R 13	34.66
R 14	40.14
R 15	52.54

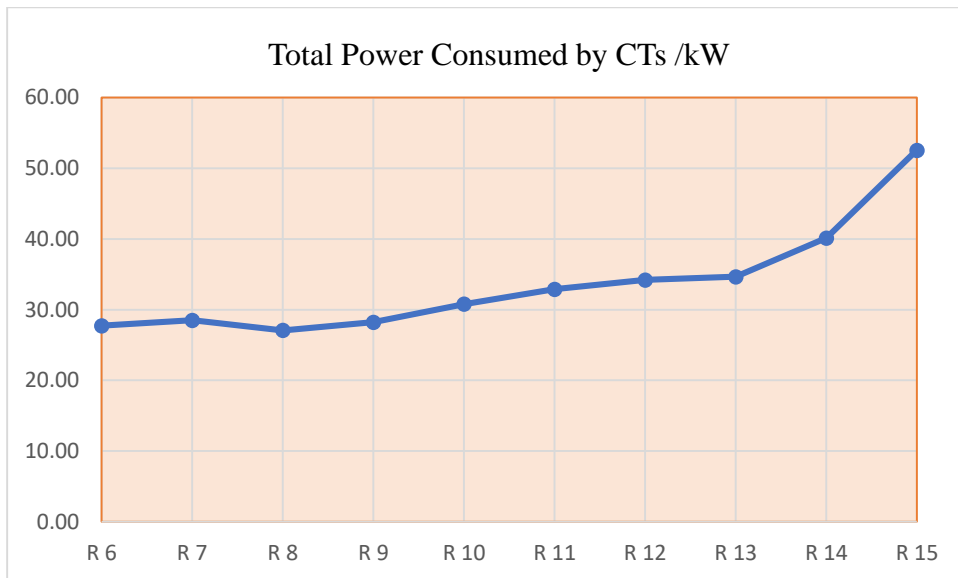

Chart 8 : Total Power Consumed by CTs /kW

Table 21 : Cooling tower fan speed

Cooling tower fan speed	COP
R 6	7.358
R 7	7.368
R 8	7.529
R 9	7.529
R 10	7.605
R 11	7.771
R 12	7.877
R 13	7.876
R 14	7.876
R 15	7.904

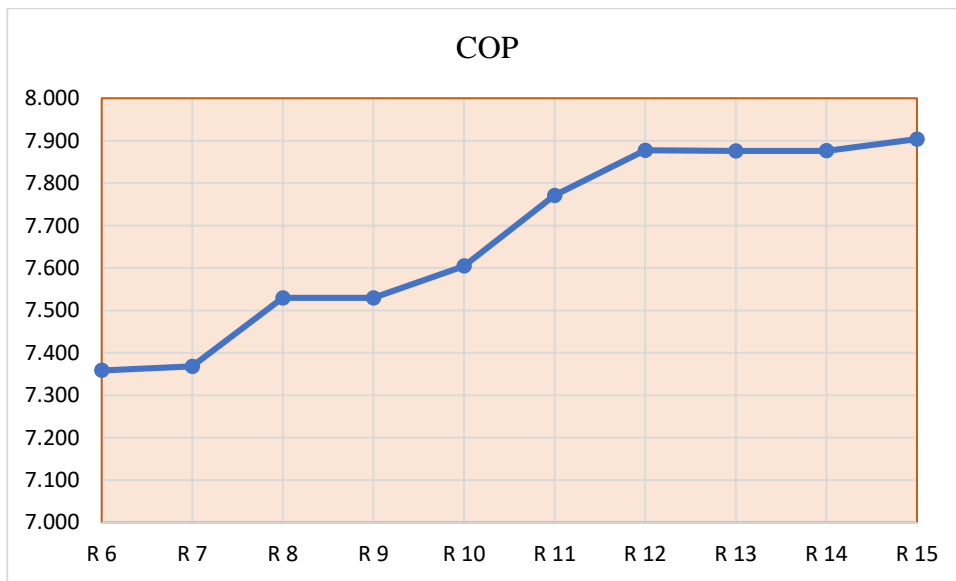

Chart 9 : COP

3.1.6.3. Mathematical Analysis

Table 22 : comparison of the cost of electrical power of each fan speed

Cooling Tower Fan Motor Speed	Cooling Tower Power Cost in Rs. (with VFD) - @19.20 Rs/kWhr	Chiller Power Cost in Rs. (Ave. F.L.) - @19.20 Rs/kWhr	Total Cost - Rs/kWhr
R 6	532.52	10,305.46	10,837.98
R 7	547.40	10,292.17	10,839.57
R 8	519.76	10,071.50	10,591.26
R 9	542.09	10,071.50	10,613.58
R 10	590.98	9,971.80	10,562.78
R 11	631.37	9,758.38	10,389.75
R 12	656.88	9,626.44	10,283.32
R 13	665.38	9,628.34	10,293.72
R 14	770.61	9,627.99	10,398.60
R 15	1,008.70	9,594.40	10,603.11

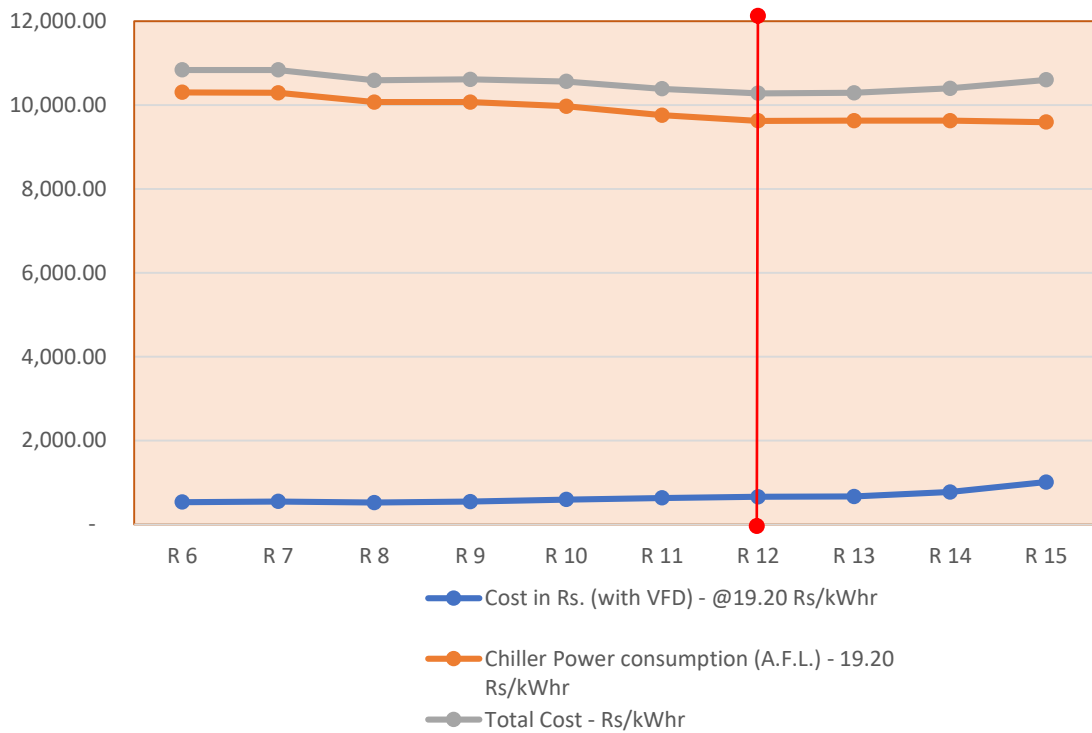

Chart 10 : Cost of Power Rs./kWhr



Better fan speed of cooling tower

3.1.6.4. Observation of Stage 2:

- At the better cooling tower configuration, optimization of the Approach could be done with gradual changing of fan motor speeds.
- High power consumption is caused by acceleration of fan speed.
- Lower fan speed is increased the temperature of Cooling Tower Leaving water.

Chapter-4

Conclusions and Recommendations

4.1. Conclusions

Above study was based on chiller selected based on AHRI conditions and CTI certified Cooling Tower. System comprises of 900 TR capacity chiller which is coupled to 2 Nos. 800 TR cooling towers totaling 1600 TR.

It was revealed that adding an extra cooling tower increases the efficiency of the chiller by 1.45 %. When one cooling tower is added to the system (3 towers in the system), chiller efficiency increased by 1.45%. When three towers are added to existing two towers, chiller efficiency was increased only by 0.8%. On the contrary increasing of cooling towers obviously increases make up water quantity & cost of water treatment, which should be carefully studied.

Increasing the fan speed of the cooling tower had various out comes. Efficiency of the chiller increased when the CT fans speed increased as VSD frequency increased up to 45Hz. Beyond 45 Hz of the VSD setting, chiller efficiency did not increased significantly. However, it caused increasing the fan motor power, thus decreasing the total efficiency of the system.

Hence following conclusions were made:

1. Increasing cooling tower capacity always improves the efficiency of the chiller systems however it limits to a certain tower combination.
2. Optimum operation point has been 3 nos. cooling towers (2400 TR) for 900 TR chiller.
3. Changing fan speed utilizing VSDs had significant impact on total system efficiency.
4. Optimization of cooling tower efficiency was evident, when 30 kW fan motor speed was reduced by VSD from 50Hz to 45Hz, the power consumption reduced 23%.

4.2. Recommendations

Every HVAC system should be optimized after certain months of operation after first commissioning of the system. It is understood that the best time for system optimization is two to three years after commissioning, when all the zones are occupied and achieves the full loading. Optimization of the cooling towers has significant payback. Optimum speed for lowest fan motor power without affecting the chiller performance should be monitored via BMS. Installation of VFDs for the fan motor provides the flexibility of fine-tuning the optimum operation point. As a warning it should be noted, under any circumstances condensing temperature should not be increased to a limit that affects the COP that reduces refrigeration effect and increase compressor power.

Optimum operation of the system could be achieved when cooling tower capacity is increased 2 to 3 times, which could be used as rule of thumb in practice.

Proportional Integral Derivative (PID) controller

Introducing of a PID loop to vary the speed of cooling Tower Fan motor according to the Condenser Entering water temperature, is more useful to get optimum fan speed at every time.

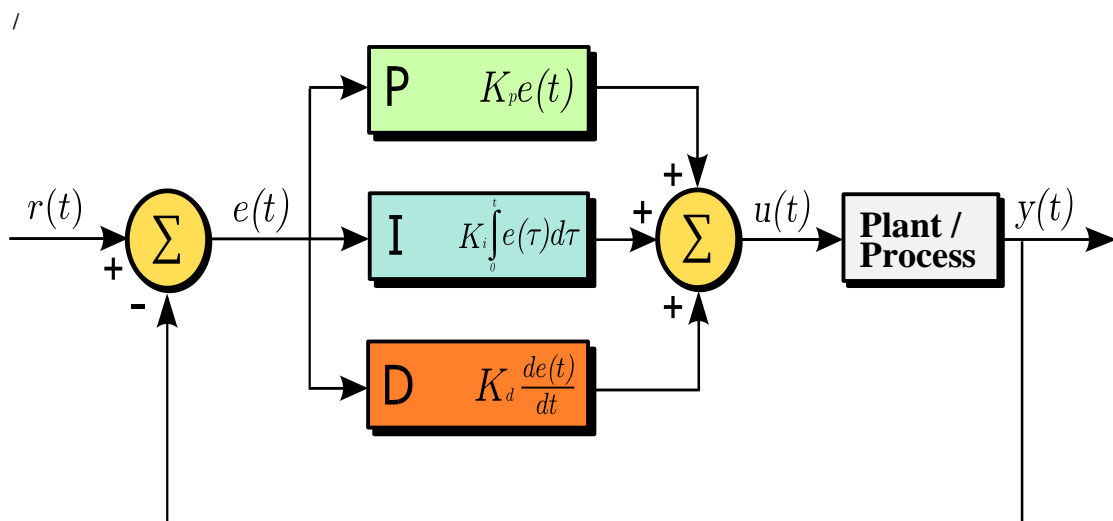

Figure 22 : PID control loop

Further studies

- Same research can be carried out for different type of cooling towers.
- Effectiveness of low temperature, Condenser Entering Water on chiller performance.
- Changing of chiller performance with differ condenser water flow rates

Chapter-5

Reference

References

- [1] "Central air conditioner and refrigeration," [Online]. Available: <http://www.central-air-conditioner-and-refrigeration.com/basic-refrigeration-cycle.html>. [Accessed 15 10 2016].
- [2] " Inverter Drive Systems Ltd - energy efficiency motor control," Inverter Drive Systems Ltd, [Online]. Available: <https://www.inverterdrivesystems.com/cube-law/>. [Accessed 13 10 2018].
- [3] "Slideplayer," [Online]. Available: <https://slideplayer.com/slide/15883966/>. [Accessed 26 08 2018].
- [4] "Chiller," [Online]. Available: <https://en.wikipedia.org/wiki/Chiller>. [Accessed 15 10 2016].
- [5] "Air handler," [Online]. Available: https://en.wikipedia.org/wiki/Air_handler. [Accessed 15 10 2016].
- [6] "Ceiling Cassette Chilled Water Fan Coil Unit," Koppel, Inc, [Online]. Available: <http://www.koppel.ph/products/ceiling-cassette-chilled-water-fan-coil-unit/#..> [Accessed 15 10 2016].
- [7] "Cooling Tower Marley Anna Laberge," Tighe-Zeman Equipments LLC, [Online]. Available: <http://www.tighe-zeman.com/cooling-towers/cooling-tower-marley-anna-laberge/>. [Accessed 15 10 2016].
- [8] V. Mulyandasari, COOLING TOWER SELECTION AND SIZING (ENGINEERING DESIGN GUIDELINE), Johor Bahru - Malaysia: KLM Technology Group, 2011.
- [9] Bureau Of Energy Efficiency, "Cooling Tower," Bureau Of Energy Efficiency.
- [10] "The Tower Design," Industrial refrigeration equipment, [Online]. Available: <https://www.ref-wiki.com/technical-information/147-condensers-and-cooling-towers/31781-cooling-towers-design.html>. [Accessed 22 11 2016].
- [11] S. Thorat, "Learnmech," Learnmech, [Online]. Available: <https://learnmech.com/what-is-cooling-towers-types-of-cooling-towers/>.

- [12] "Difference Between Natural Draft And Forced Draft Cooling Towers," Kooldrop cooling tower PVT LTD, [Online]. Available: <https://www.kooldrop.com/blog/difference-between-natural-draft-and-forced-draft-cooling-towers>. [Accessed 22 11 2016].
- [13] "Technical Resources," Matrix, [Online]. Available: <http://www.matrixcooling.com/technical-resources/>. [Accessed 22 11 2016].
- [14] "Types of Cooling Towers – Natural Draft and Mechanical Draft," Bright Hub Engineering, [Online]. Available: <https://www.brighthubengineering.com/hvac/100882-hvacr-cooling-towers-and-their-types/>. [Accessed 22 11 2016].
- [15] M. R. M. Donald Kasten, *Assessing the Performance of Cooling Towers and Their Effect on Chiller Efficiency*, New Jersey, 2007.
- [16] S. C. Technologies, *Cooling Tower Fundamentals*, Kansas, USA: SPX Cooling Technologies, Inc.
- [17] "Process Cooling," [Online]. Available: <https://www.process-cooling.com/articles/88448-cooling-tower-basics-piping-and-controls#>. [Accessed 23 11 2016].
- [18] A. Chiasson, "Sciencedirect," 2016. [Online]. Available: <https://www.sciencedirect.com/science/article/pii/B9780081003374000152>.
- [19] T. Doyon, "Plant Services," 02 12 2008. [Online]. Available: <https://www.plantservices.com/articles/2008/258/>. [Accessed 22 11 2016].
- [20] IMPROVING ENERGY EFFICIENCY IN COOLING TOWER DESIGN, Marley, an SPX brand.
- [21] E. Hajidavalloo, R. Shakeri and M. Mehrabian, M.A. Thermal performance of cross flow cooling towers in variable wet bulb temperature. *Energy Convers. Manag.*, 2010, pp. 51, 1298–1303..
- [22] M. Lucas, J. Ruiz, P. Martínez, A. Kaiser, A. Viedma and B. Zamora, Experimental study on the performance of a mechanical cooling tower fitted with different types of water distribution systems and drift eliminators. *Appl. Therm. Eng.*, 2013, pp. 50, 282.
- [23] G. Jin, W. Cai, L. Lu, E. Lee and A. Chiang, A simplified modeling of mechanical cooling tower for control and optimization of HVAC systems. *Energy Convers. Manag.*, 2007, pp. 48, 355–365..

- [24] P. Engelmann, D. Kalz and G. Salvalai, Cooling concepts for non-residential buildings: A comparison of cooling concepts in different climate zones. *Energy Build.*, 2014, pp. 82, 447–456.
- [25] L. Lu, W. Cai, Y. Chai and L. Xie, Global optimization for overall HVAC systems—Part I problem formulation and analysis. *Energy Convers. Manag.*, 2005, pp. 46, 999–1014.
- [26] C. Chang, S. Shieh, S. Jang, C. Wu and Y. Tsou, Energy conservation improvement and ON–OFF switch times reduction for an existing VFD-fan-based cooling tower. *Appl. Energy*, 2015, pp. 154, 491–499..
- [27] H. Sayyaadi and M. Nejatolahi, Multi-objective optimization of a cooling tower assisted vapor compression refrigeration system. *Int. J. Refrig.*, 2011, pp. 34, 243–256.
- [28] E. Rubio-Castro, M. Serna-González, J. Ponce-Ortega and M. Morales-Cabrera, Optimization of mechanical draft counter flow wet-cooling towers using a rigorous model. *Appl. Therm. Eng.*, 2011, pp. 31, 3615–3628.
- [29] G. Cortinovis, J. Paiva, T. Song and J. Pinto, A systemic approach for optimal cooling tower operation. *Energy Convers. Manag.*, 2009, pp. 50, 2200–2209..
- [30] H. Sane, C. Haugstetter and S. Bortoff, Building HVAC control systems—role of controls and optimization. In *Proceedings of the American Control Conference*, vol. 6, In *Proceedings of the American Control Conference*, Minneapolis, MN, USA, 14–16 June 2006.
- [31] C. Marques, C. Fontes, M. Embiruçu and R. Kalid, Efficiency control in a commercial counter flow wet cooling tower. *Energy Convers. Manag.*, 2009, pp. 50, 2843–2855.
- [32] E. Al-Bassam and R. Alasseri, Measurable energy savings of installing variable frequency drives for cooling towers' fans, compared to dual speed motors. *Energy Build.*, 2013, pp. 67, 261–266.
- [33] A. K. M. M. a. K. Kant, "Knowledge base for the systematic design of wet cooling towers", Paper," 1996.
- [34] J. Braun and G. Diderrich, Near-Optimal Control of Cooling Towers for Chilled Water Systems, 96, 806–816., 1962, p. 1962.
- [35] J. Urchueguía, E. Alakangas, I. Berre, L. Cabeza, P. Grammelis, W. Haslinger, R. Hellmer, D. Mugnier, P. Papillon and G. Stryi-Hipp, "Common Implementation Roadmap for Renewable Heating and Cooling Technologies: European Technology Platform on Renewable Heating and Cooling; Technical Report;

- Renewable Heating and Cooling (RHC-Platform)," Brussels, Belgium, 2014, 2014.
- [36] A. Mohiuddin and K. Kant, "Knowledge base for the systematic design of wet cooling towers. Part I: Selection and tower characteristics. Int. J. Refrig.," 1996.
- [37] S. K. (. K. Wang, "Handbook of air conditioning and refrigeration," in air conditioning and refrigeration., Shan K. Wang—2nd ed. p. cm. Includes index. ISBN 0-07-068167-8, 2009.
- [38] Daeil Aqua Co., Ltd. (n.d.). Cooling Tower Thermal Design Manual. Daeil Aqua Co., Ltd. hanafos. Retrieved from <http://myhome.hanafos.com/~criok/english/publication/thermal/thermal0eng.html>
- [39] Yow, K. Y. (2016, 09 09). Tips for High performance Chiller Plant. ASHRAE GreenGuide - Design, Construction, and Operation of Sustainable Buildings, 3rd. ASHRAE.
- [40] Thomas Hartman, P. (2001, september). All-Variable Speed Centrifugal Chiller Plants. ASHRAE Journal, 9.
- [41] Taylor, S. T. (2012, June). Optimizing Design & Control Of Chilled Water Plants. ASHRAE Journal, 5, 20. Retrieved from www.ashrae.org.
- [42] Takashi Hara, S. K. (1995). Non-linear finite element analysis of a reinforced concrete cooling tower shell. Engineering Computations.
- [43] Stewart, D. J. (1983). Selecting and Installing a Cooling Tower. Emerald.
- [44] Pacific Northwest National Laboratory. (2011, February). Cooling Towers: Understanding Key Components of Cooling Towers and How to Improve Water Efficiency. Energy efficiency & renewable energy, 9. U.S. DOE-Federal Energy Management Program. Retrieved from www.eere.energy.gov/informationcenter
- [45] M KALPANA, D. M. (2018). ANALYSIS AND DESIGN OF COOLING TOWER. International Journal of Pure and Applied Mathematics, 119, 8. Retrieved from <http://www.acadpubl.eu/hub/>
- [46] Hansberry, D. (2014). Chiller Plant Efficiency. Association of professional energy managers, (p. 76).
- [47] Engineering. Hong Kong: Emerald Group Publishing Limited. Retrieved from www.emeraldinsight.com/0263-2772.htm

- [48] Fu Wing Yu, K. T. (n.d.). Energy management of chiller systems by data envelopment analysis. The Hong Kong Polytechnic University, Department of Building Services
- [49] Emerson, A. G. (1962, 01). CORROSION in CHILLED WATER SYSTEMS. p. 4.
- [50] Prof. Ajit Prasad Dash, K. K. (2016, April). Design of mechanical draftcooling tower and determination of thermal efficiency. International Journal of Scientific Development and Research (IJS DR), 1(4), 7. Retrieved from www.ijedr.org
- [51] B Bhavani Sai, I. S. (2013, May). DESIGN OF COOLING TOWER. International Journal of Scientific & Engineering Research, 4(5), 1560-1563. Retrieved from <http://www.ijser.org>
- [52] B.A.Chowdhury, M. ., (n.d.). Design and performance analysis of a cooling tower in sulfuric acid plant.
- [53] Dileep KJ, D. K. (2017, May). Design and Fabrication of Cooling Tower. International Journal of Latest Engineering Research and Applications, 02(05), 27-37. Retrieved from www.ijlera.co
- [54] Rubio-Castro, E.; Ponce-Ortega, J.M.; Nápoles-Rivera, F.; El-Halwagi, M.M.; Serna-González, M. & Jiménez-Gutiérrez, A. (2010). Water integration of eco-industrial parks using a global optimization approach. Industrial and Engineering Chemistry Research, Vol. 49, No. 20, (September 2010), pp. 9945-9960, ISSN 0888-5885.
- [55] Medardo Serna-González, A. J.-G.-O.-C. (2011, September). Optimal Design of Cooling Towers. México. Retrieved from <https://www.researchgate.net/publication/221917080>
- [56] SPX COOLING TECHNOLOGIES, INC. (2016, 04). Cooling Tower Performance. Cooling Tower Performance. OVERLAND PARK, KS: SPX COOLING TECHNOLOGIES, INC. Retrieved from www.spxcooling.com
- [57] Bureau of Energy Efficiency. (n.d.). COOLING TOWER. Bureau of Energy Efficiency.
- [58] Xiaoxiao Li, H. G. (2017, September 13). Experimental study of cold inflow effect on a small natural draft dry. Applied Thermal Engineering, 762–771. Retrieved from www.elsevier.com/locate/apthermeng
- [59] YILMAZ, A. (2010). ANALYTICAL CALCULATION OF WET COOLING TOWER PERFORMANCE WITH LARGE COOLING RANGES. Çukurova

University, Faculty of Engineering & Architecture, Department of Mechanical Engineering. Retrieved from alpyil@cu.edu.tr

- [60] Serna-González, M.; Ponce-Ortega, J.M. & Jiménez-Gutiérrez, A. (2010). MINLP optimization of mechanical draft counter flow wet-cooling towers. *Chemical Engineering and Design*, Vol. 88, No. 5-6, (May-June 2010), pp. 614-625, ISSN 0263-8762.
- [61] Singham, J.R. (1983). *Heat Exchanger Design Handbook*, Hemisphere Publishing Corporation, USA.
- [62] El-Dessouky, H. T.-H.-J. (1997). A modified analysis of counter flow wet cooling towers. *Journal of Heat Transfer*, 119, 617-626.
- [63] Halasz, B. (1999). Application of a general non-dimensional mathematical model to cooling towers. *International Journal of Thermal Sciences*, 38, 75-88.
- [64] (2001). ASHRAE (American Society of Heating, Refrigerating and Air-Conditioning Engineers) Handbook, Fundamentals, Chapter 6 (Psychometrics). Atlanta.
- [65] Solberg, P. (2007, September). Ice Storage as Part of a LEED Building Design. *Engineers*
- [66] Braun, J.E. and G.T. Diderrich.(1990) “Near Optimal Control of Cooling Towers for Chilled-Water Systems.” *ASHRAE Transactions* 96, no. 2: 806-13.
- [67] Guven, H. and J. Flynn. (1992). “Commissioning TES systems.” *Heating, Piping, Air Conditioning Magazine* January.
- [68] Hartman, T. (2000). “Chiller plant control using gateway technologies.” *Heating, Piping, Air Conditioning Magazine* January
- [69] Redden, G.H. (1996). “Effect of variable flow on centrifugal chiller performance.” *ASHRAE Transactions* 102(2).
- [70] Frayne, C. (1999). *Cooling water Treatment: Principles and Practice*, CHEMICAL. Company Incorporated (NY).
- [71] Milford, R. (1984). Nonlinear behavior of reinforced concrete cooling towers. PhD thesis. University of Illinois at urbana.
- [72] Ragupathy, R. R. (2011, 6 3). Thermal Performance of Forced Draft counter Flow Cooling tower with Expanded Wire Mesh Packing. *International Journal Technical and Physical Problems of Engineering (IJTPE)*, 19-23.

- [73] Y.Lu. (2015). Small Natural Draft Dry Cooling Towers For Renewable Power plant. Dissertation/Thesis. The University of Queensland, School of Mechanical and Mining Engineering .