

**INVESTIGATION OF BLOOMING
ON NON BLACK NR - BASED STRAPS
OF RUBBER SLIPPERS**

By

M.A.A. MUNASINGHE

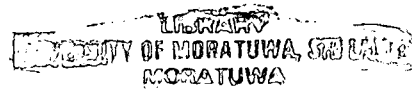

**Dissertation submitted as partial fulfillment of the award
of the degree of Master of Science in Polymer technology,**

University of Moratuwa - Sri Lanka



University of Moratuwa, Sri Lanka.
Electronic Theses & Dissertations
www.lib.mrt.ac.lk

Polymer Technology Division

Department of Chemical And Process Engineering

University of Moratuwa – Sri Lanka

Date - October 2004

University of Moratuwa



82708

Supervisor – Mr. K. Subramaniam

University of Moratuwa.

82708

66 "04"
678(043)

Thesis

82708

Acknowledgement

First of all I would like to thank the department of Chemical Engineering of the University of Moratuwa, which conducts the M.Sc course in Polymer Science. I take this opportunity to thank the course coordinator and my internal supervisor Mr. Subramaniam, Prof. Mrs. Sivagurunathen, internal and visiting lecturers and all others who helped to make a success of this post graduate course. I sincerely thank the Librarian and staff of the University library too who helped me to do my searches and studies by making available all the resources they possessed.

Bata Shoe Company of Ceylon Ltd also must be gratefully mentioned, for granting permission to follow the post graduate course and allowing me to complete the M.Sc. project in their factory. During this exercise the role of my external supervisor Mr. Daya De Silva, Laboratory Manager of the Bata Shoe Company of Ceylon Ltd., is unforgettable and I extend a big thank you to him for everything he has done so far. M/s. A.V.P. Amarasinghe and W.D. Warnasooriya, Assistant Chemists of the Bata Shoe Company of Ceylon Ltd., also deserve a special thank you for their support extended to me, while I was engaged in practical sessions inside Bata laboratory.

The great support received from the staff of the Rubber research Institute of Sri Lanka (RRISL) is also admirable and I wish to extend a special thank you to Dr. L.M. K. Thilakaratne, Director, Mrs. A.H.L. Nilmini and Mrs. Indrani of the Polymer Chemistry Department and also the Librarian.

Names of very important people from reputed Rubber Manufacturing companies in Sri Lanka should also be mentioned. Mr. H.G. Siriwardena and Mr. D Jayantha of Trelleborg Lanka, Mr. Sydney Pereira

of Damro Group and S.A.D.Saman Kumara of Samson Rubber Industries (Pvt) Ltd., of DSI Samson Group are a few among them.

I offer my special thanks to Mr. Lalith Ranatunga, Managing Director and his staff of Global Information Systems, Gampaha for their fullest corporation in making this research project a success. A big thank you to Miss Sriyani Wijewickrama for her support in type setting this project report.

I gratefully remember my family members, namely my loving parents “Amma” eternally caring for me, “Appachchi” for spending money for my education, my loving wife and her parents who always encouraged me and my brothers and sisters, who admired this effort. I owe my gratitude to the people who love and sustain the polymer Industry of Sri Lanka despite the numerous threats and constraints imposed on it by selfish short sighted behaviour of politically motivated decision makers. .

Finally I remember my little daughter “Aloka” who gave me thousands of ambitions about the future.

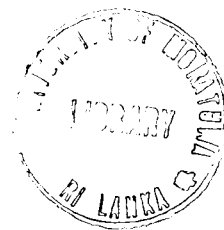

Abstract

Blooming is the appearance of powdery deposits on the surface of a rubber product. It occurs, whenever a rubber product contains an incompatible ingredient in excess of soluble quantity. Blooming is considered to be a major defect in rubber products. It spoils the smooth shiny rubber surface and impairs the aesthetic appeal of the product.

Blooming can also aid passage of air to the rubber mass and thus can cause oxidative degradation of rubber molecules.

Since this blooming phenomenon (defect) occurs very often in non – black Natural Rubber (NR) – based straps, the important tension – members of rubber slippers, an investigation has been made in this project with a view to rectify the defect and improve the breaking strength of straps.

The results of investigation reveal that the blooming of the strap is caused by the insoluble phenolic antioxidant which is a component of the protective system that has been added in excess quantity, into the rubber.

Further it has also been found that about a 15% reduction in the amount of phenolic antioxidant added and inclusion of 0.15 pphr of zinc - di-ethyl dithiocarbamate completely prevent the bloom, and impart desirable aging resistance to the rubber.

Content

Page

Chapter 1

Introduction	1
1.1. Literature survey	2
1.1.1. Ideal situations for prevention of blooms	2
1.1.2. Types of blooms.....	3
1.1.3. True blooms	3
1.1.4. Modified blooms	4
1.1.5. Pseudo blooms	5
1.1.6. Surface contamination	6
1.1.7. Staining or discolorations.....	6
1.1.8. Hazing	7
1.1.9. Frosting	7
1.1.10. Advantages and disadvantages of bloom.....	8
Advantages of wax blooming	9
Instances of blooms considered as disadvantage.....	9
Disadvantages of sulphur blooming	9
1.1.11 Toxicological consequences (Health hazards).....	11
1.2 Aim of the project	11

Chapter 2

Blooming on rubber surface	12
2.1 Techniques used for analysis of bloom	12
2.1.1 Analysis of bloom	12
2.1.2 Removal of bloom for analysis.....	12
2.1.3 Pre- analytical check – list	13
2.1.4 Analytical methods	16
2.1.4.1. Spot tests	16
2.1.4.1.1. Carbon disulphide test.....	16
2.1.4.1.2. Piperidene test.....	17
2.1.4.2 Multiple Internal Reflectance Infrared Spectroscopy (MIR)..	17
2.1.4.3. Scanning Electron Microscopy (SEM)	19
2.1.4.4. FTIR (Fourier Transform Infrared Spectroscopy)	23
2.1.4.5. Thin Layer Chromatography (TLC)	24
2.2 Experimental	27



2.2.1	Investigating of blooming	27
2.2.2	Analysis of bloom by means of Fourier Transforms Infrared spectrometer (FTIR) Preparation of KBr tablet	27
2.2.2.1	Results.....	28
	Fourier Transform Infrared Spectroscopy (FTIR) Evidence	28
2.2.	Discussion of results of investigation of blooming Analysis of FTIR evidence.....	33

Chapter - 3

Designing rubber mixes	35
3.1 Rubber strap – mix formulation	35
3.1.1 Choice of rubber	36
3.1.2 Choice of reinforcing polymer	36
3.1.3 Other ingredients	37
a) Colour	37
b) China clay.....	37
c) Activators.....	37
(I) Zinc oxide (ZnO)	37
(II) Stearic acid.....	38
d) Accelerators.....	38
(I) Mercaptobenzo thiazole sulphenamide (MBTS)	38
(II) DI phenyl guanadine (DPG)	38
(III) Zinc diethyl dithiocarbamate (ZDC)	39
e) Antioxidant	39
f) Wax	39
g) Process oils	40
h) Sulphur	40
3.2 Experimental	41
a) Experimental work.....	41
b) Processability tests	43
c) Physical testing of vulcanisates	43
d) Assessment of blooming	49

3.3	Results.....	50
	a) Rheographs	50
	b) Physical test results.....	52
	c) Visual observation after 14 days exposure.....	60
3.4	Discussion of the results	61
	a) Processability test results	61
	b) Physical properties test results.....	61
	c) Assessment of blooming.....	61
3.4.1	Photos of blooms.....	63
 Chapter - 4		
	General discussion and conclusions	64
	4-1 Investigation of blooming	64
	4-2 Mix formulation and properties	64
	4-3 Possible further work.....	65
	4-4 Conclusion.....	66
	References.....	67-68



University of Moratuwa, Sri Lanka
Electronic Theses & Dissertations
www.lib.mrt.ac.lk

List of Tables

		Page
Table 1	Factors causing blooms	2
Table 2	Rubber strap – mix formulation	35
Table 3	Formulations with variable quantities of antioxidants	42
Table 4	Cure characteristics (Monsanto rheometer)	51
Table 5	Breaking load of stem button - Toe	52
Table 6	Breaking load of stem button –Inside	53
Table 7	Breaking load of stem button- Outside	54
Table 8	Tensile strength of test compounds	55
Table 9	Modulus of test compounds	56
Table 10	Elongation at break of test compounds	57
Table 11	Hardness of test compounds	58
Table 12	Ageing 7 days at 70°C test results	59



List of Figures

	Page
Figure 1 Diagrammatic representation of MIR	18
Figure 2 Schematic Diagram of a Scanning Electron Microscope	20
Figure 3 Bloom of sulphur crystals on partly cured rubber products	21
Figure 4 Bloom of sulphur crystals with large accelerator crystal	21
Figure 5 Bloom' – actually fungus growth	22
Figure 6 'Bloom'–actually loss of surface gloss due to stress-relaxing oxidation	22
Figure 7 Plate : Thin Layer Chromatography	25
Figure 8 Apparatus for Daylight Exposure	26
Figure 9 FTIR Spectrum of brown strap sample	28
Figure 10 FTIR Spectrum of blue strap sample	29
Figure 11 FTIR Spectrum of red strap sample	30
Figure 12 FTIR spectrum of phenolic antioxidant presently used	31
Figure 13 Comparison of bloomed red sample with control	32
Figure 14 Comparison of bloomed blue sample with control	32
Figure 15 Probable antioxidant structure	33
Figure 16 Tensometer with thong strap holding device	44
Figure 17 Dimension of dumb-bell knife for tensile test	45
Figure 18 Rheograph of sample compounds superimposed	50
Figure 19 Average breaking load of stem button - Toe	52
Figure 20 Average breaking load of stem button - Inside	53
Figure 21 Average breaking load of stem button - Outside	54
Figure 22 Average tensile strength of test compounds	55
Figure 23 Average modulus of test compounds	56
Figure 24 Average elongation of test compounds	57
Figure 25 Average hardness of test compounds	58
Figure 26 Average ageing of test compounds	59
Figure 27 Bloomed strap sample- 01	63
Figure 28 Bloomed strap sample- 02	63

Chapter 1

Introduction

Blooming is one of the major defects which causes severe damage to rubber products. Smoothness of the surface of the article disappears due to the accumulated powder or bloom, which in the long term, badly affect the products sale ¹.

Blooming may occur due to addition of incompatible rubber ingredients in excess of quantities (above the solubility parameter) recommended for normal use, and improper processing conditions. ²

The following can be quoted as examples of chemical ingredients that normally bloom to the surface of rubbers, if used in excess quantity.

1. Paraffin wax
2. Stearic acid
3. Oils (aliphatic type)
4. Accelerators
5. Antioxidants
6. Sulphur etc.

University of Moratuwa, Sri Lanka.
Electronic Theses & Dissertations
www.lib.mrt.ac.lk

1.1. Literature Survey

1.1.1. Ideal situations for prevention of blooms

Blooming will not occur if the additive is either totally insoluble at processing temperature or totally soluble at room temperature.³

Table 1 : Factors causing blooms

Example	Concentration of additive	Solubility at ambient temperature	Solubility at processing temperature	Expected effect
1	X	0	0	No blooming
2	X	<X	<X	No blooming
3	X	<X	>X	Blooming unless nucleated in-situ by another additive
4	X	>X	>X	No blooming

1.1.2 Types of blooms

Several research works have been undertaken by the Malaysian Rubber Producers Research Association MRPRA on blooming and they have recorded much information on the subject. According to their best findings, four major types of blooms have been identified and they are i) true blooms, ii) modified blooms, iii) pseudo blooms and iv) surface contamination.⁴

1.1.3. True Blooms

The mechanism of the blooming of crystalline materials is simple. In broad theoretical out lines the substance, which blooms, must have a limited but appreciable solubility in the rubber and be present in excess of this solubility. This excess will exist as discrete particles throughout the mass of the rubber either because it has never dissolved at the temperature of vulcanization, or it crystallized out on cooling.⁴

These discrete particles can easily be seen in sections cut from pure gum rubber and examined by transmitted light under the microscope. In this crystallizing it must be assumed that local strain is set up in the rubber displaced by the formation of the crystal. This strain results in pressure on the crystal, the solubility of which is increased thereby. At the free surface crystals of the material can form without distortion of the rubber and the solubility will be unaffected. The free energy of crystallization will therefore be less at the surface than in the bulk of the rubber; the solubility of substance will also be slightly less. There will therefore be a concentration gradient of dissolved material which will cause diffusion from the inside towards the surface and this will persist until all the material crystallized in the bulk has dissolved under the influence of pressure and diffused outwards. The magnitude of the increased solubility due to pressure will be of course, be minute as also will the



concentration gradient within the rubber, but large forces are not necessary to account for the observed phenomena.⁴

eg.

- I. Free sulphur is probably the most common substance to cause a true bloom, and in vulcanized product such a bloom may be due to undercure⁴
- II. Zinc dithiocarbamates are also known to give true blooms and of the three common ones, the dimethyl-, diethyl- and dibutyl- dithiocarbamates, (ZDMC, ZDEC & ZDBC respectively) it is the middle one which shows the most rapid and, over a period of time, the densest bloom. The order of solubility is $ZDMC < ZDEC < ZDBC$ and it is therefore concluded that the soluble fraction of ZDMC is relatively low, resulting in a low rate of migration, whilst ZDBC is sufficiently soluble for the solubility limit not normally to be exceeded and thus for there to be no bloom. But it is unfortunate that ZDBC give a slower rate of cure than the other methyl or ethyl types and that is therefore not practicable to use it.⁴
- III. Mercaptobenzothiazole (MBT) and Zinc mercaptobenzothiazole (ZMBT) have also been observed to cause true bloom.
- IV. Protective waxes being the cause of complaints concerning true blooms.

1.1.4. Modified Blooms

Certain chemicals presents within the matrix of a rubber vulcanizate react either deliberately or not, with constituents of the environment and this result in a significantly different mechanism of blooming.

eg.-

- I. Paraphenylenediamine class antioxidants (PPD) which, protect the rubber compound by reacting with ozone (O_3) to form an insoluble protective skin on the surface.
- II. Zinc salts of carboxylic acids constitute further examples of both true and modified blooms.

Zinc stearate has a known solubility in cis-polyisoprene of about 0.3% and thus the addition of 1pphr stearic acid and 2–5 pphr Zinc oxide should inevitably produce a bloom. Zinc stearate itself is oily and thus gives an oily bloom but, in moist atmospheres, this react with water vapour at the surface of the rubber to produce “basic zinc stearate” which forms on the surface as a solid layer, visually indistinguishable from a bloom, and completely insoluble in the rubber. A true zinc stearate bloom can be dissolved back in to the rubber by heating, but this is not the case with the basic salt.⁴



University of Moratuwa, Sri Lanka
Electronic Theses & Dissertations
www.lib.mrt.ac.lk

1.1.5. Pseudo blooms

On a surprisingly large number of occasions it has been found that mat effect on an initially smooth shiny surface has not been seen due to the blooming of a particular compound, or to deposition of a contaminant, but due to the degradation of the rubber surface itself. The pitted surface, which develops results in sufficient light scattering to give the impression of a bloom.⁴ On prolonged exposure to weathering conditions like oxygen, sunlight or ozone, random cracks appear on the surface of rubber products making it look like an “elephant’s skin formation”. As a result of these random cracks, the inert mineral fillers present in the rubber will also chalk. This effect is known as crazing.¹

1.1.6. Surface Contamination

Organic fillers used as dusting agents tend to be present in the air of most factories and can adhere to freshly moulded rubber surfaces, giving the appearance of a bloom. One of the most obvious causes of surface contamination is silicone oil, used as a mould release agent. Not only does it impart an oily film to the surface but it also given a base to which dirt and dusting powders may adhere. The washing of rubber products also gives rise to contamination if rinsing is inadequate and both inorganic salts and organic materials have found their way on to the surface of rubber articles by this route⁴

1.1.7. Staining or Discolorations

Although these terms tend to be used interchangeably it is probably better to consider discoloration as applying to the rubber article itself, and stain as describing the effect produced on a material in contact with the compounded or cured rubber. In the vast majority of cases these effects are brought about by free sulphur or dithiocarbamates in contact with copper, as both copper sulphide and copper dithiocarbamate are very dark coloured and give a visible stain even at a parts-per-million level. Trace metals such as iron and copper in the rubber itself can also give rise to discolouration, as well the use of Zinc oxide with an over-high level of lead. In these cases the problem is identifying the source of the excessive levels of trace metal, although the usual culprits are fillers and dyes. Perhaps one of the hardest problems is in defining at what level these elements become effective discolorants.⁴

There is no doubt that the form in which the trace metals exist substantially affects the amount which can be tolerated in a vulcanizate but, broadly speaking, if one has discoloration problems and the copper level exceeds 20 ppm, or the iron 150 ppm, then this is probably the root causes of the effect.⁴

Certain phenolic antioxidants are known to give a pink colour to rubber products although this is generally faint and thus only noticed with light coloured or transparent formulations.⁴

The effects of staining antioxidants particularly paraphenylene diamines are, of course, well known and a test for their presence would be the first thing to carry out if a purple, blue or brown stain or discoloration is observed.⁴

1.1.8 Hazing

Haze is defined as a cloudy appearance within or on the surface of a transparent article, and from a visual inspection it is often difficult to distinguish between it and a bloom.⁴

1.1.9. Frosting



University of Moratuwa, Sri Lanka.
Electronic Theses & Dissertations
www.lib.mrt.ac.lk

Many rubber products are known to show the appearance of whitish dry patches on their surface making such products unusable. This is quite common in white or light coloured products and specially in those containing large amounts of cheap white fillers. The same phenomenon is also noticed in black products when the black is used merely as a pigment but the vulcanisate in-fact contains a lot of white fillers. The problem described is actually known as frosting.¹

The inorganic fillers, which are involved here, are actually not soluble in the elastomer. Therefore they cannot bloom, as they cannot migrate. What actually happens is that the surface of the vulcanisate is destroyed due to various types of aging and the filler particles are pushed out to the surface mechanically. This layer of filler is partially held by the vulcanisate during the initial stages, and later the same can be removed by some mechanical means. But one immediately notices that once the loose filler layer is removed another

partially held layer appears on the surface still making the vulcanisate visually unusable. The process tends to continue and that is why it is not possible to restore the value of a light or bright coloured rubber product once frosting has been encountered. This situation can be considered worse than the blooming of a material in rubber products, which often can be removed without making the product unusable. Resistance to frosting is related to resistance against oxygen and mostly ozone attack. This explains why NR and IR show easy frosting while CR, IIR and EPDM rubbers have good resistance to frosting.¹

Considering the possibility of frosting and higher loading of cheap fillers, china clay is found to be better than calcium carbonate. It has also been found that the best protection against frosting is usually obtained by the correct choice of fillers and accelerators. Microcrystalline waxes along with non-staining antidegradants are often used here.¹



University of Moratuwa, Sri Lanka.
Electronic Theses & Dissertations
www.lib.mrt.ac.lk

1.1.10. Advantages and disadvantages of blooms

Advantages of antioxidant and antiozonant blooming (leaching)

Antiozonants like paraphenylenediamine (PPD), which protect the rubber by reacting with ozone to form an insoluble protective skin on the surface. This results in a deficiency of PPD in the layer of rubber nearest the atmosphere and there is a migration of the PPD from the bulk rubber to eliminate the concentration gradient. As more PPD reaches the surface layer it react with ozone and the process of migration continues until the 'skin' of oxidized PPD prevents further ozone penetration, and enables a constant concentration to be established throughout the bulk of the rubber.⁴

Advantages of wax blooms

This is one of the instances where blooming is considered as beneficial. Blooming waxes are purposely used along with other anti-degradants to stabilize polymers, oxygen, ozone etc. That level of protection, which can be derived by the use of wax, depends on many factors. The degree of migration of the wax, the molecular at and type of paraffin's in the wax, temperature of application, degree of cross linking in the vulcanisate, presence of softeners and plasticizer etc., are some of them. Using paraffin wax, microcrystalline wax or combination of them are common sight in the shoe manufacturing industry and the formation of surface wax blooms which give some physical protection because the flexible protective barrier prevents ozone attack at the polymer surface provided it is not disrupted.⁵



University of Moratuwa, Sri Lanka.
Electronic Theses & Dissertations
www.lib.mrt.ac.lk

Instances of blooms considered as disadvantage

Blooming, frosting, bleeding, hazing or what ever phenomenon occurred, all of them are visually offensive effects, and the appearance of a surface deposit or a colour change is quite sufficient to cause rejection of the product during manufacture, storage or service. The consequences of this are just as commercially harmful as mechanical damage or a more catastrophic physical failure.

Disadvantages of Sulphur blooming

Although long time ago it was considered that a coating of bloomed sulphur could be an advantage as it may provide some ageing resistance, this view is not held anymore. Due to blooming of sulphur, calendared material loses tackiness, which effects, further processing and assembly of

blanks. In tyre cord, conveyer belts, laminated articles etc.; this loss of tackiness can become a serious problem.¹

In some cases when the blanks with a coating of bloomed sulphur are vulcanized, uneven cure can be seen. In light coloured products dark spots appear where serious accumulation of sulphur has taken place, and in the rest of the surface there are brownish yellow patches. In addition to these visual defects the technical properties of the vulcanisate will also vary from place to place.



1.1.11. Toxicological consequences (Health Hazards)

It is true that most of the rubber chemicals are toxic and harmful to the human body. Sometimes they are carcinogenic or show some allergy.⁶

eg. : Antioxidants. (phenyl β naphthylamine - PBN)

Migration and ultimate physical loss of antioxidants into the contact media can have severe toxicological consequences in addition to the risk associated with premature failure of the polymer product. Safety of antioxidants is a major issue in polymer stabilization and stringent regulations are already in place, in most countries, on the use of antioxidants for application involving the human environment.

eg. : Food packaging and medical implants.

1.2 Aim of the project

The Organisation for which I work (Bata Shoe Company of Ceylon Ltd., Ratmalana) blooming is a serious problem in the rubber slippers. It occurs especially in the straps, the tension members of the slippers. With a view to rectify this problem, this project work is carried out.

Thus the main aim of this project is the identification of the ingredients that cause blooming on the rubber slipper straps and to take remedial action to overcome the problem.



Chapter 2

Blooming on rubber surface

2.1 Techniques used for analysis of bloom

2.1.1 Analysis of bloom

In any analytical procedure one must decide whether to examine the surface as it stands, or to remove any bloom present and then identify it. As has been shown so many apparent blooms are actually due to different phenomena that it is generally better to carry out an 'in-situ' examination before attempting removal. ^{4,7}

2.1.2. Removal of bloom for analysis

When it is necessary to remove the bloom from the surface of the rubber for subsequent examination, there is a problem as to whether it is better to use a dry or a wet method and, if wet, which solvent to use. A 'dry wipe' has certain advantages in that one is unlikely to extract chemicals close to, but under, the rubber surface with a new clean razor blade and to remove the bloom. The bloom then is available for examination by the standard analytical techniques, such as infrared spectroscopy, liquid and thin layer chromatography. ⁷

The great difficulty in wet swabbing is in being certain that there is effectively no penetration of the solvent into the rubber surface, with consequent leaching of non-blooming components. Preferred solvents would thus be those such as acetone or methanol, which, whilst being good solvents for most of chemicals known to bloom do not swell the polymers appreciably ⁷

Nevertheless a 'control' area, which does not show a bloom should always be similarly treated and only gross differences between the two considered significant. A reduction in temperature of the rubber and solvent will help to reduce diffusion and so afford a clean bloom. A reduction from $+20^{\circ}\text{C}$ to -70°C could reduce the solvent penetration by several orders of magnitude. ⁷

One particular application of this techniques is in the use of a mixture of acetylacetone and 2-propanol (10:90) to complex and thus render soluble the normally insoluble basic zinc stearate / palmitate bloom by soaking for up to 93 hours at -26°C . Identification and quantification of the zinc and fatty acids can then be made by atomic absorption spectrometry and gas chromatography respectively. ⁴

2.1.3. Pre- analytical check – list

Before discussing in detail the methods available for the analysis of blooms and the other effects described, it is worthwhile working through a series of questions, the answers to which could assist in finding one's way through this maze. ⁴

Question (Q1) - Has the bloom developed /increased in intensity during storage?

If not, a dusting powder may be responsible.

(Q2) - Does the bloom disappear on heating ? If not, basic zinc stearate, an insoluble dusting powder such as talc, or surface degradation may be responsible.

(Q3) - Is light or exposure in the open required for the bloom, to form. If yes, surface degradation or certain antidegradants may be responsible.

(Q4) - Can the bloom be removed by a solvent wipe? If not try other solvents (a complexing agent such as acetyl acetone or lactic acid will remove basic zinc stearate). If these also fail, embedded dusting agent or insoluble may be responsible.

(Q5) - Is the surface of the rubber pitted or roughened after a solvent wipe?

If yes, surface degradation may be responsible.

If the answers to Q1, Q2 and Q4 are positive and those to Q3 and Q5 negative these probably a true bloom and the presence of an excess of a compounding ingredient or residue or a protective agent should be suspected. ⁴

If the answers to Q4 and Q5 are negative, the haze may be due not to a bloom, but to an opaque material within the rubber. If the answers to Q1 and Q2 are also negative the cause may be an insoluble filler, such as zinc oxide. Check whether the level of zinc oxide exceeds 1 pphr. ⁴

If the answer to Q2 is positive, a vulcanization residue or absorbed water may be responsible. If opaque specks are observed on holding the rubber up to the light, suspect the presence of zinc dimethyl dithiocarbamate (or TMTD, TMTM). If water is responsible, the problem should not recur after leaching and drying. ⁴

Colour changes

(Q1). Does the discoloration / stain appear to be light induced?

Check by comparing with a sample kept in the dark or with a surface hidden from light. If 'yes' an antidegradant may be responsible. A grayish or brownish discoloration may be indicative of certain phenolic antioxidants. ⁴

(Q2). Does the discoloration/ stain appear to be heat – induced?

If 'yes' and there are no signs of ageing (e.g. stickiness, embitterment, etc.), an amine antioxidant may be responsible. ⁴

(Q3). Is the discoloration uniform or patchy?

If patchy, external contamination is likely, although an additive in the rubber may still be involved. ⁴



University of Moratuwa, Sri Lanka
Electronic Theses & Dissertations
www.lib.mrt.ac.lk

(Q4). Does the discoloration/ stain appear after laundering, contact with metal parts, or only when the rubber is in contact with fibers and textiles?

If 'yes' to the first part, copper or iron contamination may be responsible; see whether there is a brown stain. Check whether dithiocarbamates are present in the formulation. ⁴

(Q5). Is the discoloration / stain accompanied by poor aging?

If 'yes' this is further evidence that copper or iron may be responsible. ⁴

2.1.4. Analytical methods

Three basic techniques can be used to identify blooms before attempting their removal. These are spot tests, multiple internal reflectance infrared spectroscopy (MIR) and scanning electron microscopy. (The latter preferably with an X – Ray elemental analysis facility) ⁷

2.1.4.1. Spot tests

Two extremely sensitive and specific test methods are used to the detection of free sulphur.

2.1.4.1.1. Carbon disulphide test

This test is called as “drop test”, as it consist simply of placing one drop of Carbon disulphide on to the suspected bloom. Here a small drop of carbon disulphide is spotted on to bloom and spread out and then dries off. Then a clean dull circular area surrounded by a line of recrystallised sulphur can be seen through a lens or microscope. ⁸

2.1.4.1.2. Piperidene test

This test is called as 'kirchhof', piperidene test. Here white or brightly coloured rubber is spotted with piperidene. In the presence of free sulphur a yellow or deep orange - red coloration occurs presumably due to the formation of polysulphide piperidene compounds. ⁸

2.1.4.2. Multiple Internal Reflectance Infrared Spectroscopy

(MIR)

Infrared spectrum of any sample can be obtained in two ways as follows

1. Shining light through it.
2. Bouncing or reflecting light off its surface.



Electronic Theses & Dissertations
www.lib.mrt.ac.lk

In both cases spectrometer compares the energy spectrum of the infrared source before and after absorption by the sample and generates a spectrum characteristics of the sample showing the wavelengths at which it absorbs energy. ⁴

It will be apparent if one obtains a spectrum of the surface 2-10 μm of a sample with a bloom on a surface, much of the spectrum will be due to that bloom. Although this is true in principle, the sample requirements of a flat piece some 2" \times 2" in area, together with the virtual absence of carbon black, which would absorb all infrared radiation, reduces its usefulness appreciably. Nevertheless bloom can be identified using this technique. Excess dusting agents or filler pseudo blooms have similarly been identified, although care must be taken when examining a white filled vulcanisate by this technique as there will inevitably be the spectrum of the filler superimposed on that of the elastomer even in the absence of bloom.

If the presence of a bloom is suspected on a black filled or other product but no useful spectrum is obtainable, it is frequently worth while removing the product from the MIR plate and inspecting the surface of the plate to see whether any transfer at bloom has occurred.⁴

A spectroscopic examination of this coated plate could then provide a spectrum free from the rubber background and thus make it more easily recognizable. This is particularly true of silicone oils, zinc stearate and other 'sticky' materials, including degraded rubber, which may itself have been thought to be a bloom.⁴

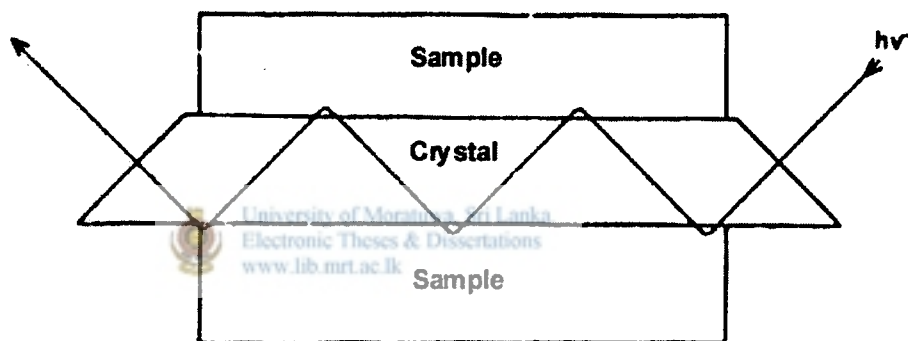

Figure 01 : Diagrammatic representation of MIR

The two events of interest here are the ejection of secondary electrons, which are processed to provide a "visual" TV image, and the generation of X-rays which, in the case of an energy dispersive X-ray analytical system, are fed to a multi-channel analyser which generates a spectrum of all elements with mass greater than sodium as a histogram on a cathode ray tube. The great depths of field, which are experienced with the Scanning Electron Microscopy (SEM), coupled with an element spectrum of the same region, thus provide many unique data.^{4,7}

2.1.4.3. Scanning Electron Microscopy (SEM)

The use of scanning electron microscopy to produce pictures of materials at very high magnification. The first true SEM was built in 1938, but this instrument was commercially available in the mid of 1960.

The scanning electron microscope with X-ray analyser, offers a unique combination of advantages. Most current applications of this machine are bio medical or biological but little published on the SEM to rubber analysis can be seen.

The principle of operation is simple and consist of bombarding the sample with a high-energy electron beam, after coating it with a conductive film less than 1 nm thick to prevent built-up of an electric charge, and monitoring the events which results there from. ⁴



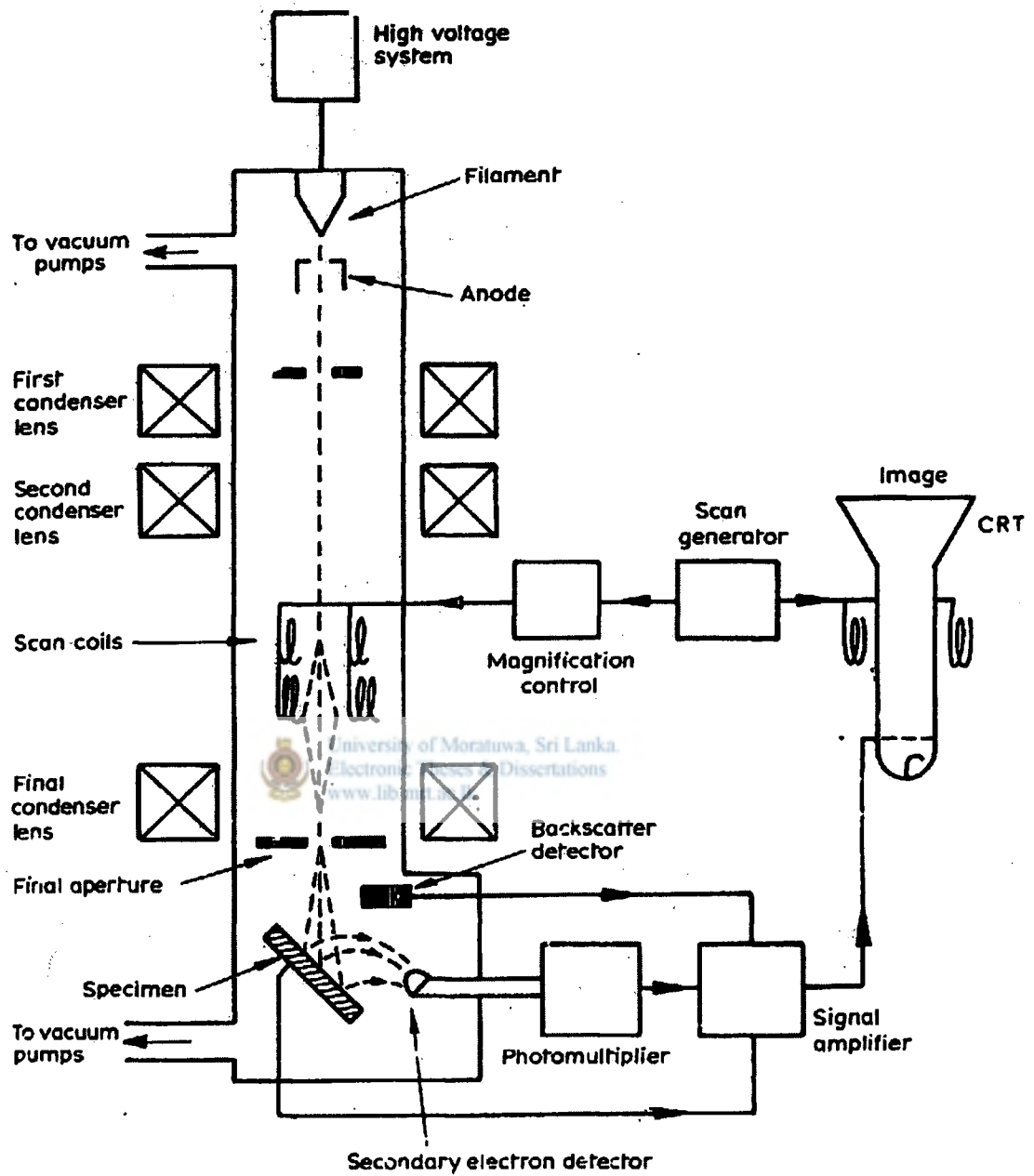

Figure 02 : Schematic Diagram of a Scanning Electron Microscope⁹

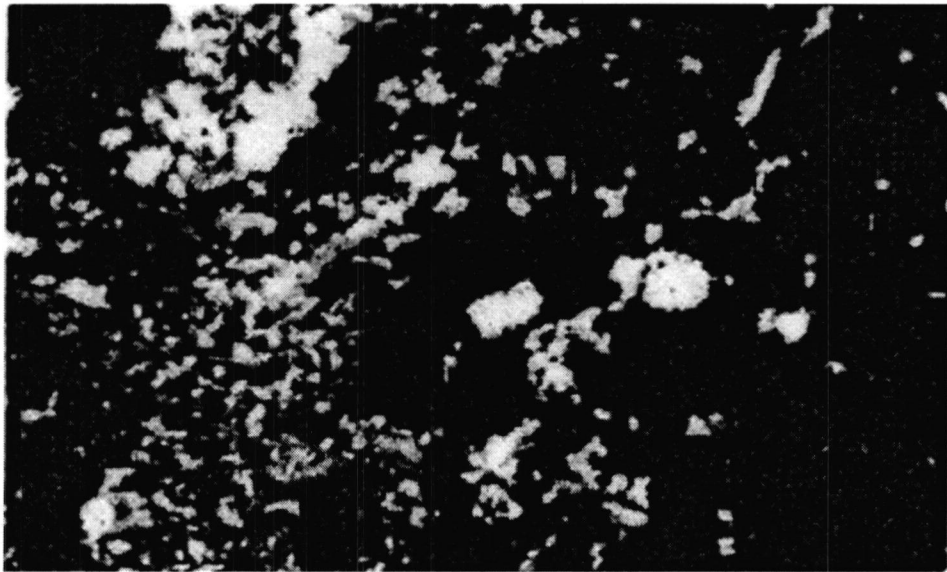

Figure 03: Bloom of sulphur crystals on partly cured rubber products × 200

(Scanning Electron Microscope Photograph) ⁴



University of Moratuwa, Sri Lanka
Electronic Theses & Dissertations
www.lib.mrt.ac.lk

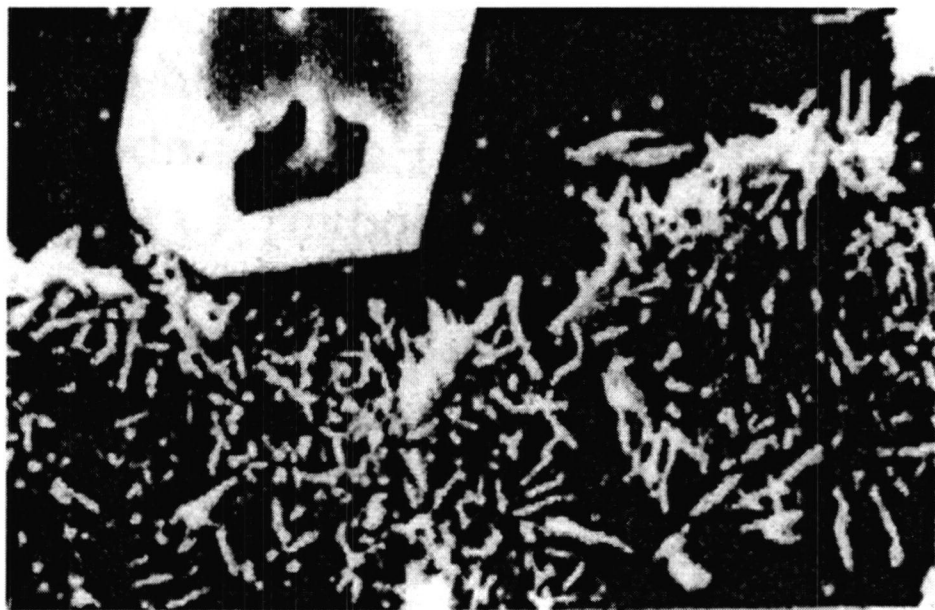

Figure 04 : Bloom of sulphur crystals with large accelerator crystal × 400

(Scanning Electron Microscope Photograph) ⁴



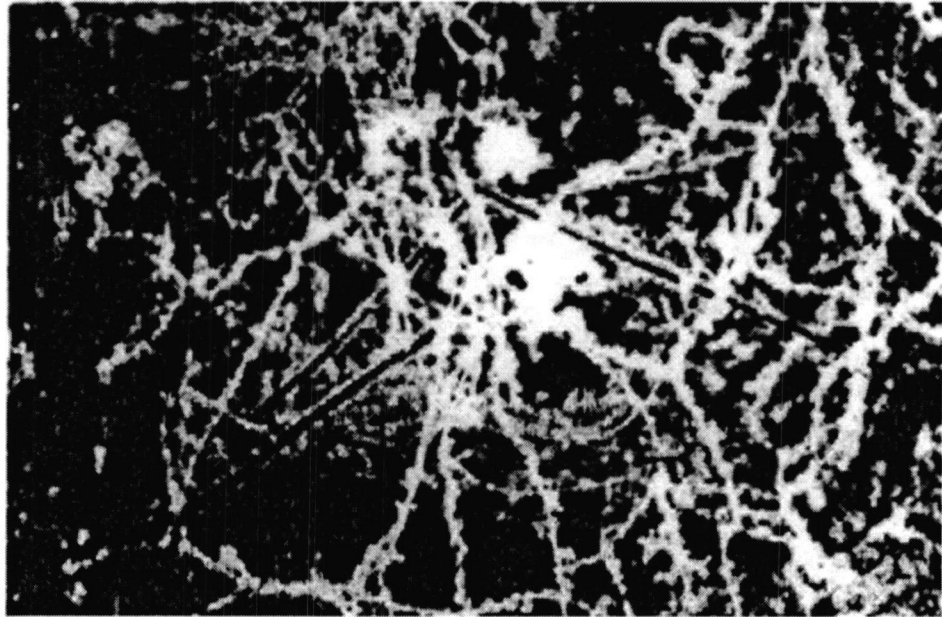

Figure 05 : 'Bloom' – actually fungus growth × 120

(Scanning Electron Microscope Photograph) ⁴

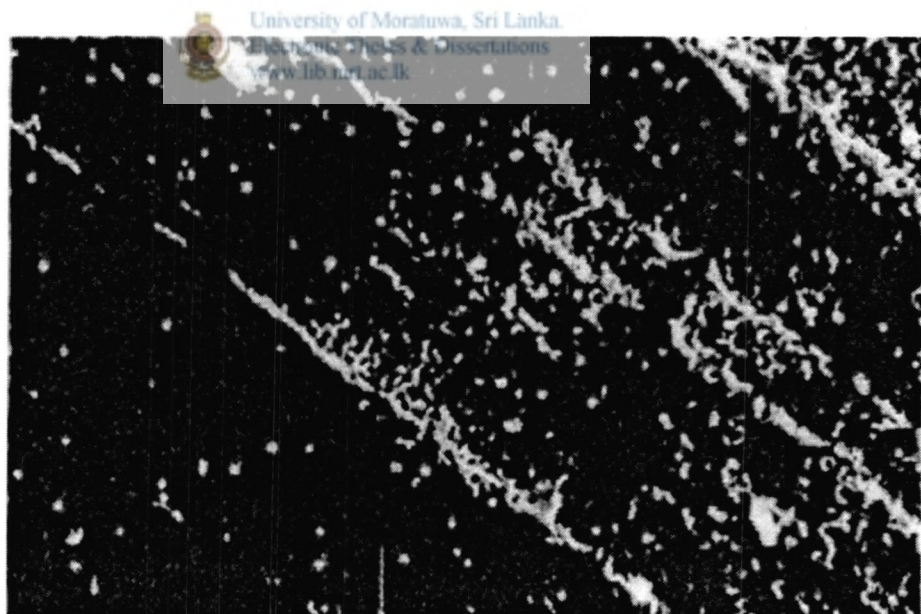

Figure 06 : 'Bloom'–actually loss of surface gloss due to

stress-relaxing oxidation × 120

(Scanning Electron Microscope Photograph) ⁴

2.1.4.4. FTIR (Fourier Transform Infrared Spectroscopy)

A fourier transform infrared spectrophotometer has superb features that in comparison with a dispersive type of infrared spectrophotometer it has a shorter analysis time and higher wave number accuracy.

This advantage of the FTIR can be even enhanced by using best-suited accessories selected from among various kinds of accessories according to the purpose of analysis.

The liquid film method and the potassium bromide (KBr) tablet method both of which are the most basic methods of Infrared Spectrophotometry and the most typical methods of measurements are diffusion reflectance method, high sensitive reflectance method, Attenuated Total Reflection (ATR) method, infrared microspectro-photometry and Gas Chromatography (GC) - FTIR method, and examples of measurement.¹⁰



University of Moratuwa, Sri Lanka.
Electronic Theses & Dissertations
www.lib.mrt.ac.lk

More specific analysis, the developments of acidic, aldehydic and ketonic carbonyl and the built up of hydroperoxide have been followed by IR spectroscopy. Until recently such measurements have invariably been made with conventional prism spectrometers, which have limited sensitivity. This lack of sensitivity has proved a handicap when the early stages of degradation are of interest. The recent commercial appearance of FTIR spectroscopy has alleviated this problem. In FTIR an interferometer is utilized instead of the prism and slits used in conventional IR spectrometry with the result that all wavelengths can be scanned simultaneously.

Since each FTIR scan takes only about 2 seconds, it is practical to make repeated scans which has the effect of increasing the signal- to-noise ratio and hence the sensitivity of the technique.¹¹

The introduction of FTIR spectrometers has revitalized the field of IR spectroscopy. Studies of complex polymeric materials that were extremely difficult using dispersive spectrometers are now readily accomplished.

Coleman and Painter in a review of the application of FTIR to the study of polymeric materials give examples of how this technique has been used to examine degraded and un-degraded systems.

Weathering effects of polymers, particularly those resulting from photo-oxidation, are generally concentrated in the surface layers and for this reason the study of polymer films has proved a fruitful approach in photo-oxidation and weathering microns transmission; IR has been widely used in degradation studies. However, attenuated total reflectance (ATR) infrared, it has been possible to study the immediate surface of thick as well as of thin sections of material.¹¹



2.1.4.5 Thin layer chromatography (TLC)

With thin Layer chromatography, it is possible to separate minute constituents present in blooms. It is relatively inexpensive, simple and fast and has good separation power. This technique is closely related with paper chromatography, having a stationary phase. This phase may be cellulose, silica or alumina. It is applied as a thin layer on a rigid support such as glass or plastic.^{1, 4}

In the procedure using TLC, place a small spot of a dichloromethane solution of the rubber extract is placed on to the coating on the plate, about 2 cm from the bottom. The plate is then kept in a glass tank with a lid, containing the desired solvents system in the bottom at a depth of about 1 cm. The solvent travels up the layer by capillary attraction. When the solvent front has reached the required height, the plate is removed from the

tank and air dried prior to visualization of the separates spots with a reactive chemical spray, or repeated development of the plate either in the same or different solvent. Components of similar structure chromatographed under the same conditions will have similar mobilities. The mobility is measured in terms of R_F which is given by the following equation.⁴

$$R_F = \frac{\text{Distance travelled by the compound}}{\text{Distance travelled by the solvent front}}$$

The thin layer chromatography is usually regarded as being semi quantitative: the logarithm of the spot area is proportional to the quantity of material in the spot. But in practice, however, visual comparison of spot size with those of series of spots containing standard quantities of the authentic material will suffice to give an estimate of quantity which is usually adequate for the examination of mixes and vulcanisates. More accurate quantitative results can in theory be obtained by the use of scanning densitometer.⁴



Figure – 07 : Plate : Thin Layer Chromatography¹²

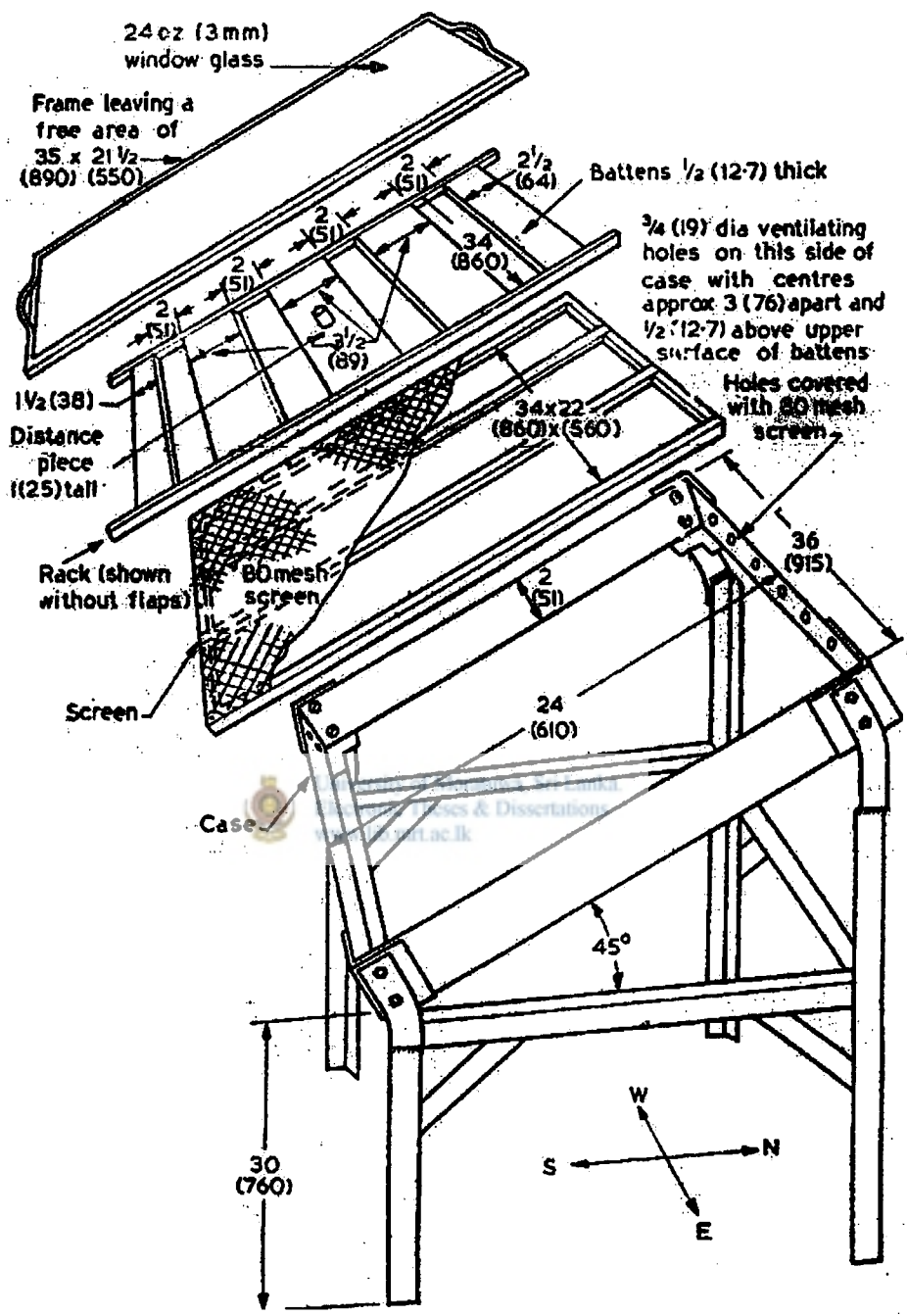

Dimensions in inches with millimetre equivalents in parentheses.

Figure - 08 : Apparatus for Daylight Exposure ¹³

2.2. Experimental

2.2.1. Investigating of blooming

Blooming appeared on the surface of straps of rubber slippers (Produced by the Bata Shoe Company of Ceylon Ltd.) was removed and analysed by FTIR (Fourier transform infrared spectrometer) from the analysis the bloom was found to contain contaminant predominately with phenolic groups.

2.2.2. Analysis of bloom by means of Fourier Transforms Infrared spectrometer (FTIR)

Preparation of KBr tablet

Bloomed sample was mixed with 200mg of properly ground KBr powder in an agate motor, and the mixture was put into the die, used to make KBr tablet. Then the pressure (8 ton / sq.inch) was applied to the mixture and kept it for about 15 minutes under vacuum. After that the transparent KBr tablet was carefully removed from the die ¹⁰.

The KBr tablet, thus prepared was analyzed for blooming, by means of FTIR. The Spectra obtained, for the samples are given under the results¹⁰.

2.2.2.1 Results

**Fourier Transform Infrared Spectroscopy (FTIR)
evidence**

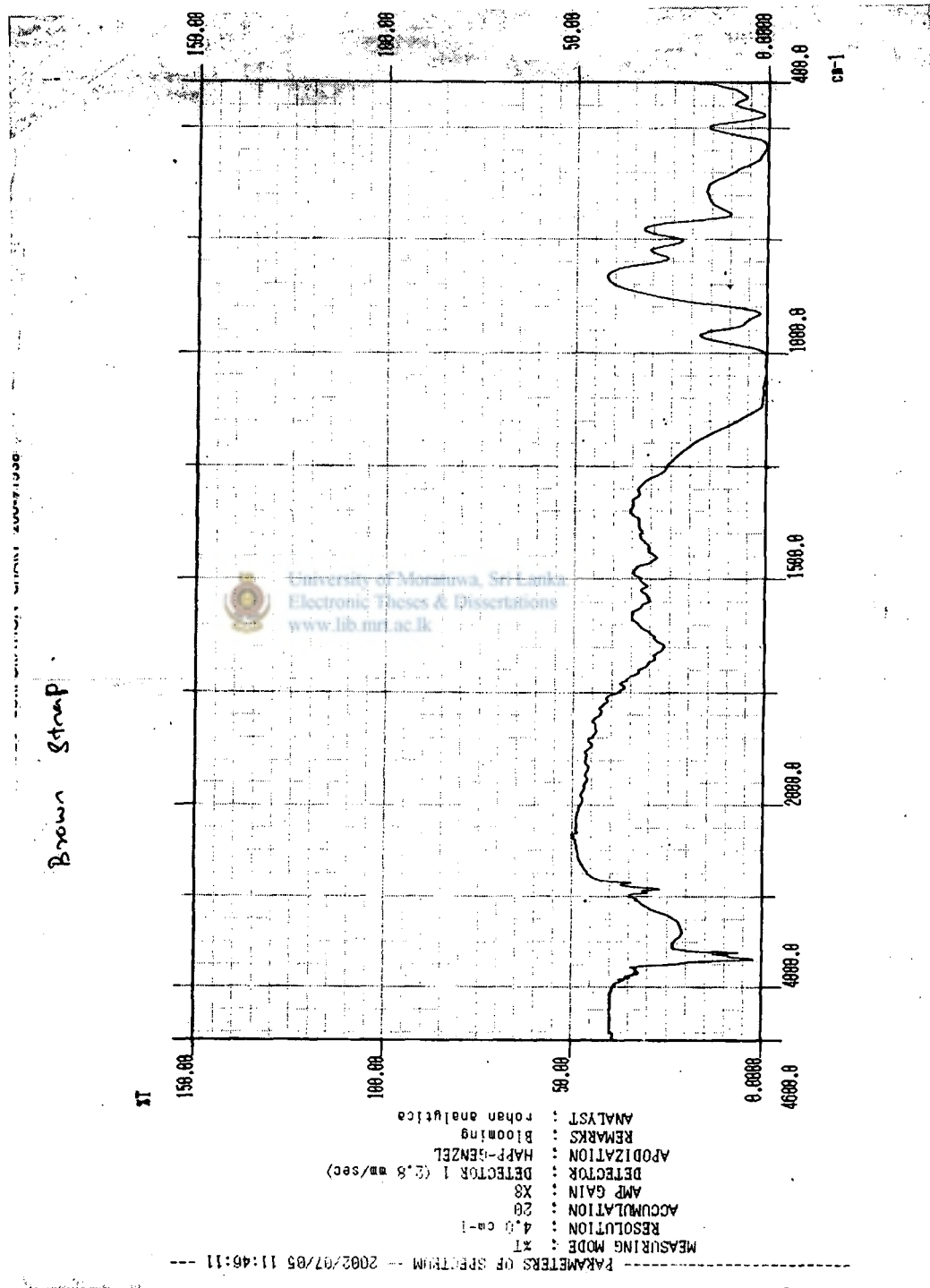

Figure - 09 : FTIR Spectrum of brown strap sample

Figure 10 : FTIR Spectrum of blue strap sample

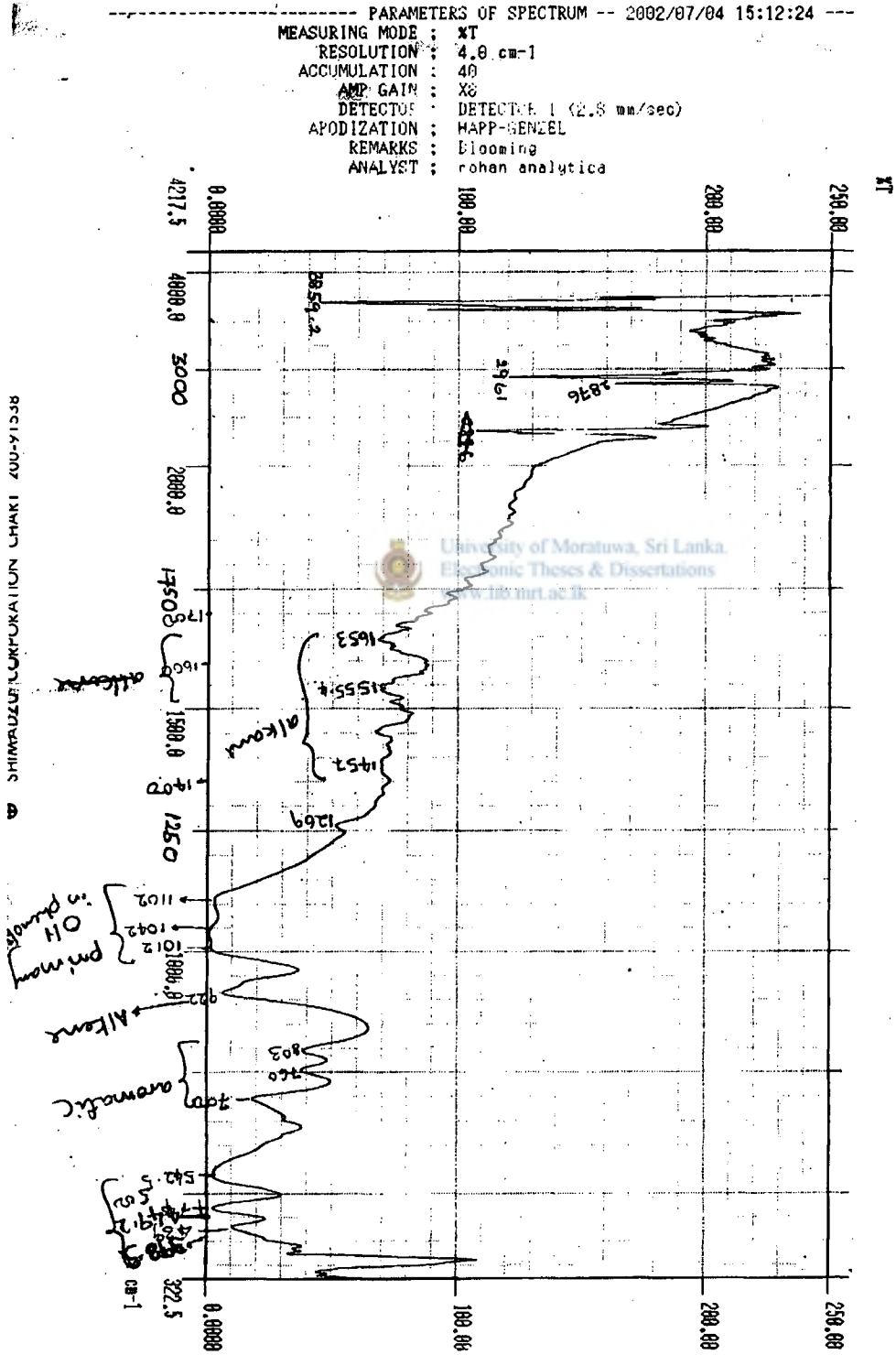
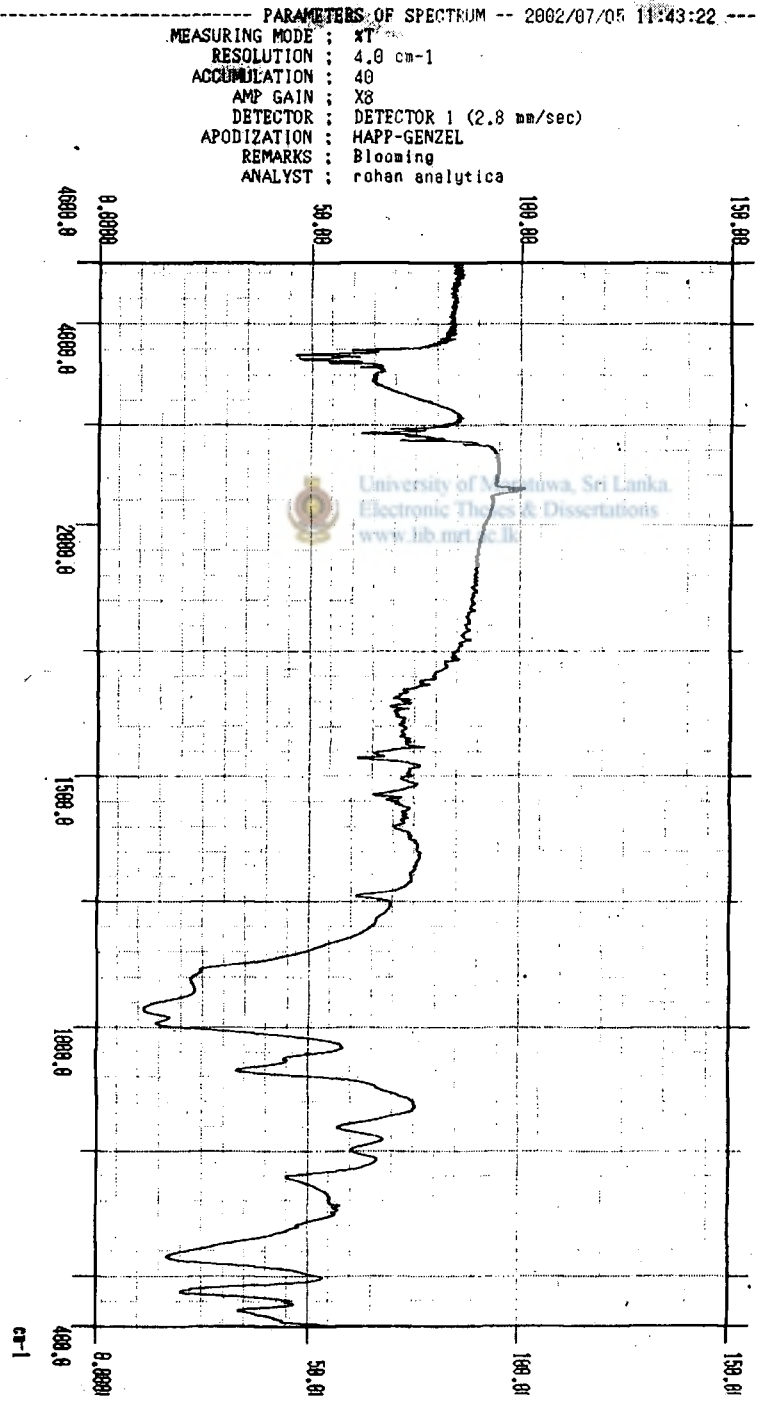



Figure 11: FTIR Spectrum of red strap sample

SHIMADZU

SHIMADZU CORPORATION CHART 200-91538



RED STRAP

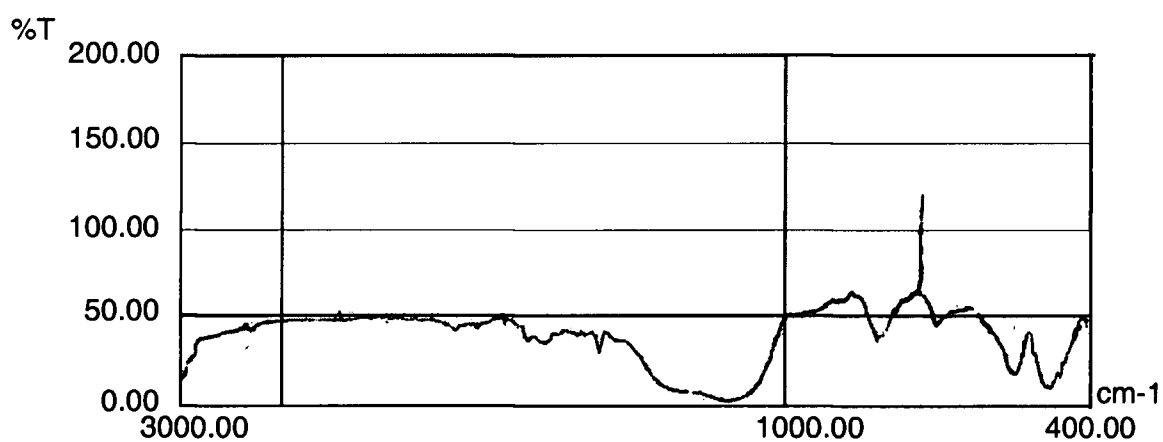

Figure 12 : FTIR spectrum of phenolic antioxidant presently used



University of Moratuwa, Sri Lanka.
Electronic Theses & Dissertations
www.lib.mrt.ac.lk

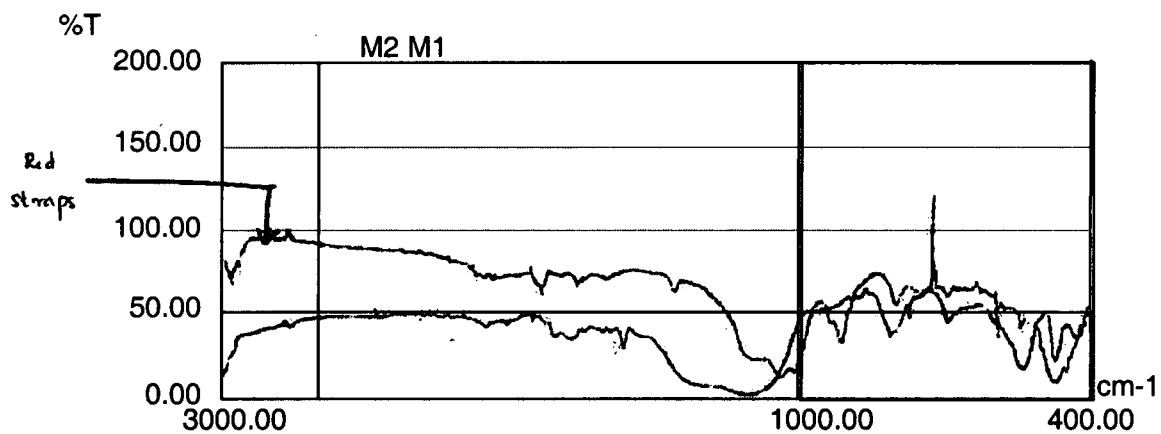

Figure 13 : Comparison of bloomed red sample with control

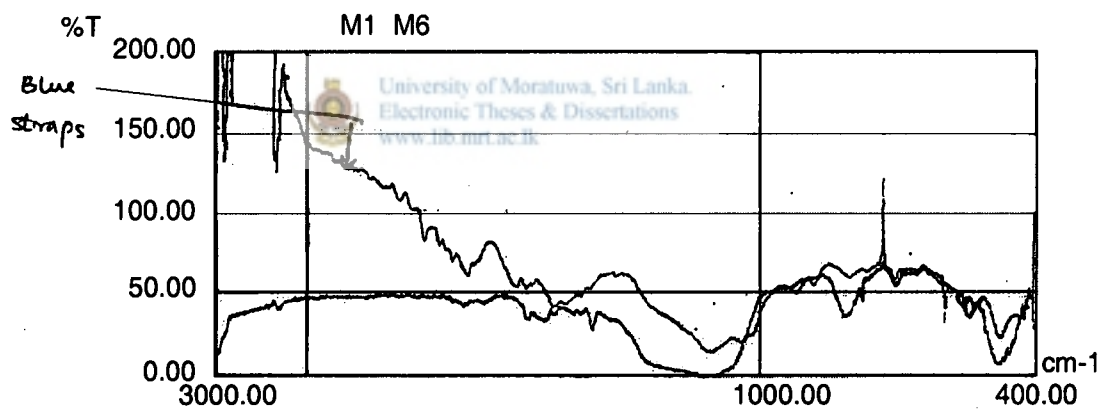

Figure 14 : Comparison of bloomed blue sample with control

2.3 Discussion of results of investigation of blooming

Analysis of FTIR evidence

According to the peak values of each spectrum it is clear that phenolic antioxidant type chemical has caused the bloom. The spectra obtained, clearly reveal that they are similar to the spectra of antioxidant we have used in formulae. ¹⁴

According to the peak values of spectra, a clear peak can be seen (830), and it is described as the aromatic ring with 2 adjacent H atoms.

A strong peak is available between 1050 and 1100 and it shows the bending and vibration of primary alcohols.

Peaks relevant to 1485 – 1470 describe about alkenes.

The probable structure of the antioxidant could be

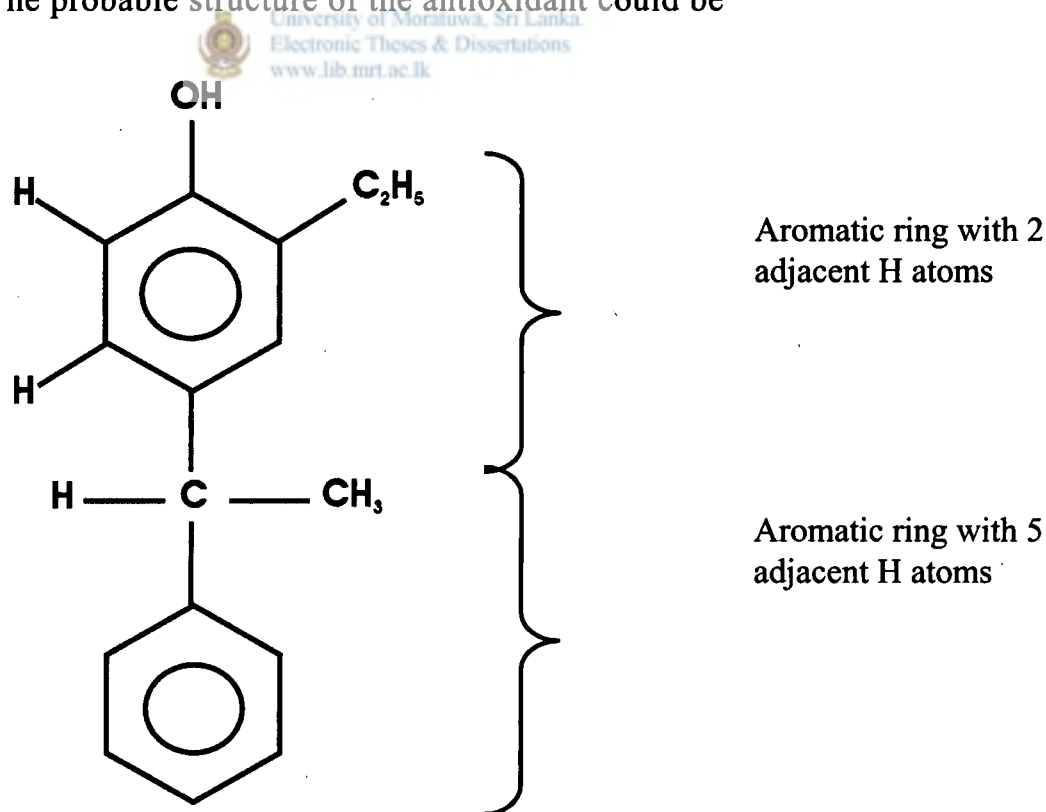

Figure 15 : Probable antioxidant structure

According to above result the chemical structure already mentioned is proved. The strong peak between “1050 – 1100” of the spectrum of red strap sample has a difference company with other two sample spectrums. But the reason for that may the insufficient matching of the signal to noise ratio of FTIR machine.



University of Moratuwa, Sri Lanka.
Electronic Theses & Dissertations
www.lib.mrt.ac.lk

Chapter - 3

Designing rubber mixes

3 -1 Rubber strap – mix formulation

The following mix formulation was used at Bata shoe company of Ceylon Limited to produce the rubber strap of slippers:

Table 2 : Mix formulation

Component	Amount pphr
Crepe Rubber	91
High Styrene	9
Pigment Master Batch	3
China Clay	75
Zinc Oxide	3.5
Stearic Acid	2
MBTS	0.72
DPG	0.48
Phenolic antioxidant	1.2
Microcrystalline wax	0.5
Process Oil	2.4
Sulphur	2.3

3.1.1 Choice of rubber :

Natural Rubber (NR) is chosen because of the following characteristics of the rubber

NR is a natural polymer which consists of almost 99.99% linear cis 1,4 polyisoprene. It is a stereo regular homopolymer thus it can be crystallized on stretching. therefore its natural strength is higher, compared with other synthetic polymers.¹⁵ NR has relatively broad molecular weight distribution. This corresponds to about 3000 to 5000 isoprene units per polymer chain. As a result of its broad molecular weight distribution, NR has an excellent processing behavior. NR should be masticated with a suitable peptiser before mixing with other chemical ingredients.¹⁵

3.1.2 Choice of reinforcing polymer:

High styrene is selected to give strength and toughness to the straps. High styrene is a SBR type synthetic thermoplastic which consists of higher percentage of styrene. This can easily be blended with NR. NR-high styrene blend improves the physical properties like tensile strengths, hardness and dimensional stability.



3.1.3 Other Ingredients

a). Colour

Organic and inorganic pigments are used for colouring of rubber compounds. Inorganic pigments usually give rather dull colours in rubber compounds, hence for brightly coloured compounds, synthetic organic pigments are used.¹⁶

Organic pigments are available in a very large range of colours and shades. They are comparatively expensive, but used in rubber goods which should be non bleeding (should not fade during vulcanising and should be light fast.)¹⁶

b). China clay



University of Moratuwa, Sri Lanka.
Electronic Theses & Dissertations
www.lib.mrt.ac.lk

This is a semi reinforcing filler, which consists of hydrated aluminium silicate. It is a greyish or off-white powder (2 μ m) which is used to improve the physical properties like tensile strength, hardness etc. This is very cheap filler and therefore the cost of the compound is reduced automatically.¹⁶

c). Activators

(i) Zinc Oxide (ZnO)

This is a universal activator used in almost all rubber compounds. The usual dosage for this purpose is 3 – 5 % of the weight of the rubber. ZnO improves the action of accelerators and this action of zinc oxide is improved by the presence of stearic acid. In a sense stearic acid accelerates the action of sulphur in the vulcanisation process.¹⁶

(II) Stearic Acid

This is also an activator for accelerator, which functions by forming zinc soap which in turn activates the accelerators. This is an organic fatty acid and the optimum dosage for rubber compound is 2 pphr. ¹⁶

d). Accelerators

The function of an accelerator is to increase the rate of vulcanisation. Normal dosage is 1 pphr.

(I) Mercaptobenzothiazole sulphenamide (MBTS)

This is a nonstaining primary accelerator and it shows good resistance to scorch. it is a medium fast accelerator having good ageing properties. Low modulus products can be made by using MBTS.

(II) Di phenyl Guanidine (DPG)

This is also a medium fast accelerator which shows scorch problems. And it is a staining secondary accelerator which can be used as a combination with other accelerators like thiazoles.

(III) Zinc diethyl dithiocarbamate (ZDC)

This is an ultra fast accelerator for dry rubber and latex industry. But this is also an antioxidant specially for the latex industry.

e). Antioxidant

Antioxidants are the chemicals which use to prevent the oxidative degradation of rubber vulcanisates. Two type of antioxidants are common in the rubber industry and they are amine antioxidant and phenolic antioxidant. Amine types are staining and phenolic types are nonstaining.

f). Wax

Two type of waxes are used in the rubber industry. They are paraffin wax and microcrystalline wax. Wax is a processing aid for the production of rubber goods. Microcrystalline wax has a comparatively higher melting point and low molecular weight distribution. Microcrystalline waxes have less tendency to bloom. Combination of both waxes can be used for rubber compounds.¹⁶

g). Process oils

These are processing aids for rubber compounds. All of these are petroleum based mineral oils available in various grades. Process oils consist of three categories. They are aromatic, naphthenic and paraffinic oils. They improve processing by softening and swelling the rubber compound. Aromatic oils give best processability but stain the vulcanisate. Paraffinic oils are non staining oils. Naphthenic oils fall between aromatic and paraffinic types in their effects on performance of rubber.¹⁶

h). Sulphur

Sulphur is the major crosslinking agent for natural rubber. Sulphur vulcanising is very cheap and easy. Sulphur cross linking system can be conventional, semi EV or EV.

Normal vulcanisation sulphur tends to bloom to the surface during storage of compounded rubber. This makes subsequent adhesion or welding steps more difficult. Blooming can be avoided by using so-called insoluble sulphur that cannot bloom because it is also insoluble in the rubber.¹⁵



3.2 Experimental

a). Experimental work

In the experimental work, five rubber mixes containing various reduced quantities of phenolic antioxidant were selected to study the blooming effect. Each mix was then tested for its processability and vulcanisate properties. Blooming in the vulcanisates of each mix was also investigated by visual inspection.

Since the vulcanisates without blooming showed weak age resistance the mix formulations which showed no blooming was again altered by the inclusion of zinc diethyl dithiocarbamate, a chemical which acts as accelerator as well as antioxidant.

The new mix containing ZDC was then prepared and tested for it's characteristics. This formulation was also modified.



Mixed formulations with reduced quantities of phenolic antioxidant used to assess blooming of rubber slipper straps.

Table 3 : Formulations with variable quantities of antioxidants

Conventional Formulations with Reduced quantities of antioxidant (pphr)						
Chemical Description	A	B	C	D	E	F
Crepe Rubber	91	91	91	91	91	91
High Styrene	9	9	9	9	9	9
Colours	3	3	3	3	3	3
China Clay	75	75	75	75	75	75
Zinc Oxide	3.5	3.5	3.5	3.5	3.5	3.5
Stearic Acid	2	2	2	2	2	2
MBTS	0.72	0.72	0.72	0.72	0.72	0.6
DPG	0.48	0.48	0.48	0.48	0.48	0.4
ZDC	-	-	-	-	0.2	0.15
Phenolic Antioxidant	1.2	1.0	0.8	0.6	0.8	0.8
Microcrystalline Wax	0.5	0.5	0.5	0.5	0.5	0.5
Process Oil	2.4	2.4	2.4	2.4	2.4	2.4
Sulphur	2.3	2.3	2.3	2.3	2.3	2.3

(b). Processability tests

Cure characteristics

The cure characteristics of each compound was determined using the Oscillation Disc Rheometer (ODR) at 160⁰C.

Preparation of Sample

Samples in the form of straps and sheets for testing were prepared under the following conditions.

Temperature of platens ----- > 160⁰ C ± 3

Hydraulic pressure ----- > 150 Kg / cm²

Curing time ----- > 5 min



University of Moratuwa
Electronic Theses & Dissertations
www.lib.mrt.ac.lk

(c). Physical testing of vulcanisates :

The test methods are exclusively designed to test the Bata footwear products. The methods are similar to the British Standard (BS) and American Society for Test Methods (ASTM).

Determination of the breaking strength of thong straps

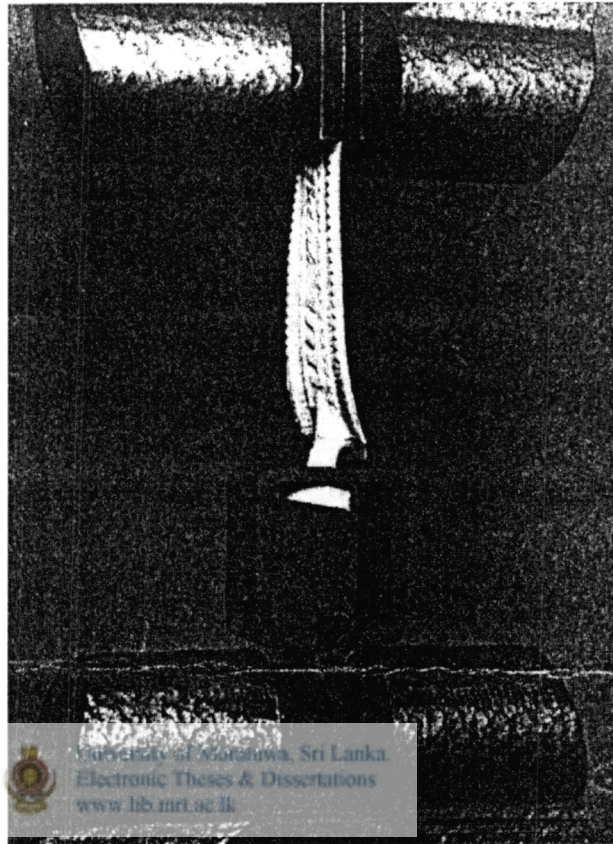

Figure 16: Tensometer with thong strap holding device¹³

The jig consists of two vertically symmetrical halves that fit together to hold the stem within 7 mm diameter operating in the upper portion was designed to fit the tensile tester grips. The stem / button at the toe and sides were tested in the same manner.

The results are presented under 3.3 (Figures, Graphs etc.,)

Determination of tensile properties of vulcanised tensile sheet.

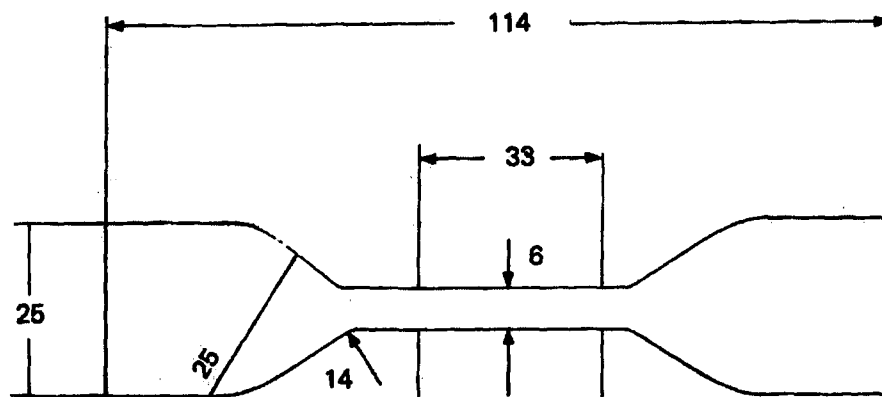

Figure 17: Dimension of Dumb-bell Knife for Tensile Strength Test¹³

Procedure

Measured the thickness of the test piece at the middle in three different places and took the average. Measured the width of the test pieces of the narrow central part by a divider or by a scale from the dumb-bell knife. Started the motor. Inserted the dumb-bell test piece into the grip of the machine taking care to adjust symmetrically to distribute the stress over the cross section to ensure that the reference lines remain parallel during stress.

Switched on the machine, checked the elongation by the scale. Recorded the final load and elongation at break.

Results

Rejected the results of test pieces that did not break between the reference marks. Took the median of at least three readings.

$$\text{Tensile Strength (MPa)} = \frac{\text{Breaking Load (N)} \times 100 \%}{\text{Width (mm)} \times \text{Thickness (mm)}}$$

$$\text{Modulus at 300 \% (MPa)} = \frac{\text{Local @ 300 \% stress}}{\text{Width (mm)} \times \text{Thickness (mm)}}$$

$$\text{Elongation \%} = \frac{\text{Final Length} - (\text{Distance between ref. line}) (2\text{cm.}) \times 100}{\text{Initial distance between reference lines (2cm.)}}$$



University of Moratuwa, Sri Lanka
Electronic Theses & Dissertations
www.lib.mrt.ac.lk



Determination of Hardness

Preparation of test pieces

Cut test pieces of 5×5 cm. and of thickness 6 mm, minimum. The test piece shall have both surfaces flat, smooth and parallel.

Procedure

Wallace hardness tester was used to test hardness. Checking apparatus: Adjusted to leave no gap between two sleeves, tightened lock screw and tightened foot-finger. Dusted the upper and lower surfaces of the test piece lightly with talc and placed it on the glass platform. Switched on the vibrator. Turned the large wheel until the foot came in contact with the test piece and pointer is in up ward position. After 5 seconds turned rim of gauge until pointer reads 100. Continued turning of large wheel until the pointer stopped. Waited for 30 seconds and read the hardness from the gauge. Repeated the test twice. Reported hardness directly as the median of three measurements.

Ageing Test (Oven Method)

Procedure

Cut out the dumb-bell test pieces from the vulcanised sheets module under specified condition. Punched a hole to allow the holder to hold them inside the cell of the ageing chamber. Put the reference marks at the centre of the test piece.

Maintained the temperature of the oven $70^{\circ} \pm 1^{\circ}\text{C}$. Placed the test pieces in the cell where there are no other test pieces of different compound.

They should be free from strain and freely exposed to air on all sides. Continued ageing for 7 days. Removed the test pieces and condition for 16 hours in a strain free condition carried out test to determine the tensile strength, modulus, elongation and hardness of at least three samples.



University of Moratuwa, Sri Lanka
Electronic Theses & Dissertations
www.lib.mrt.ac.lk

Reported all the properties before aging and after aging together and it can also be expressed at percentage of change as follows.

A – physical properties before ageing

B – physical properties after ageing

$$\text{Ageing} = \frac{(A-B)}{A} \times 100$$

(d). Assessment of blooming

Test for outdoor exposure

The strap sample of each mix was exposed to out door under the following conditions.

Time duration (Average Day time) ----> 14 days

Temperature -----> 29⁰ C – 34⁰ C

Humidity -----> 80 ± 5

During the test, samples were covered partially with black polythene film to protect the effect of UV, Light, heat and wind.



3.3 Results

a) Rheograph

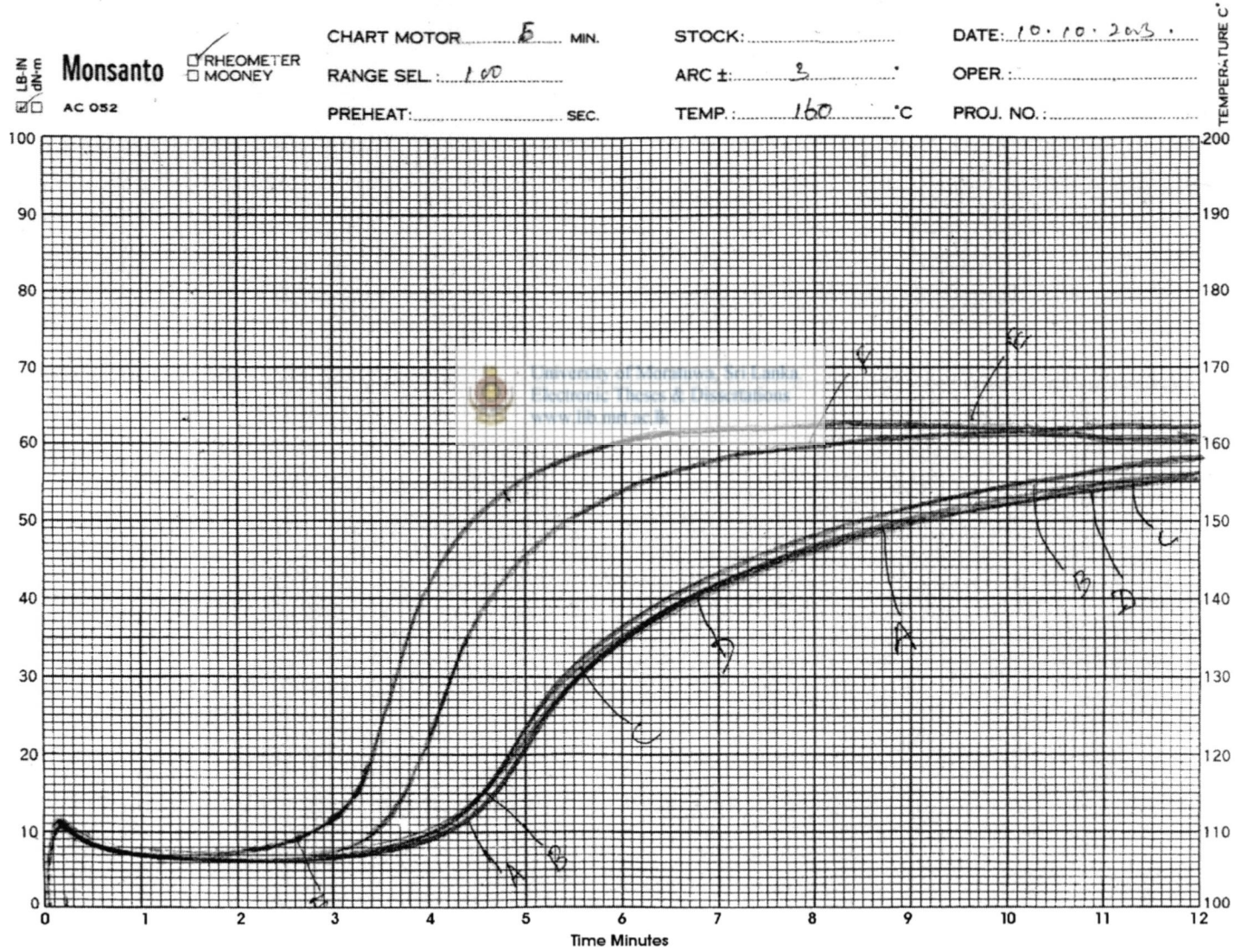

Figure 18 : Rheograph of sample compounds superimposed

Table 4 : Cure characteristics (Monsanto rheometer)

Compound	<i>T min</i> (1B In)	T max (1B In)	ts₂ sec	t 90 sec
A	6	56	93	228
B	6	58	94.5	229.5
C	6	55.5	95	230
D	6	55	95	231.5
E	7	62	65	127.5
F	6.5	61	81.25	157.5



(b). Physical test results

Table 5 : Breaking load of stem button - Toe

Breaking strengths of stem button (Toe.) N						
Test Sample	A	B	C	D	E	F
1	325	370	412	360	337	350
2	370	365	398	363	270	400
3	345	370	363	363	350	366
Average Value	346	368	391	362	319	372

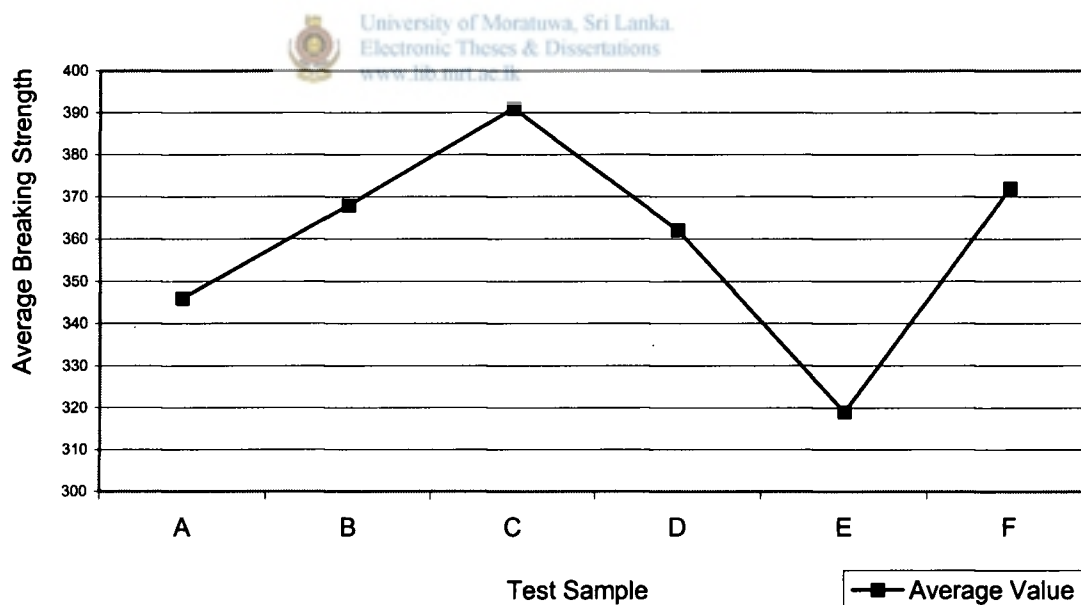

Figure 19 : Average breaking load of stem button - Toe



Table 6 : Breaking load of stem button –Inside

Breaking strengths of stem button (Inside) N						
Test Sample	A	B	C	D	E	F
1	305	329	302	321	348	325
2	321	292	342	270	262	280
3	302	314	368	270	300	286
Average Value	309	311	337	287	303	297

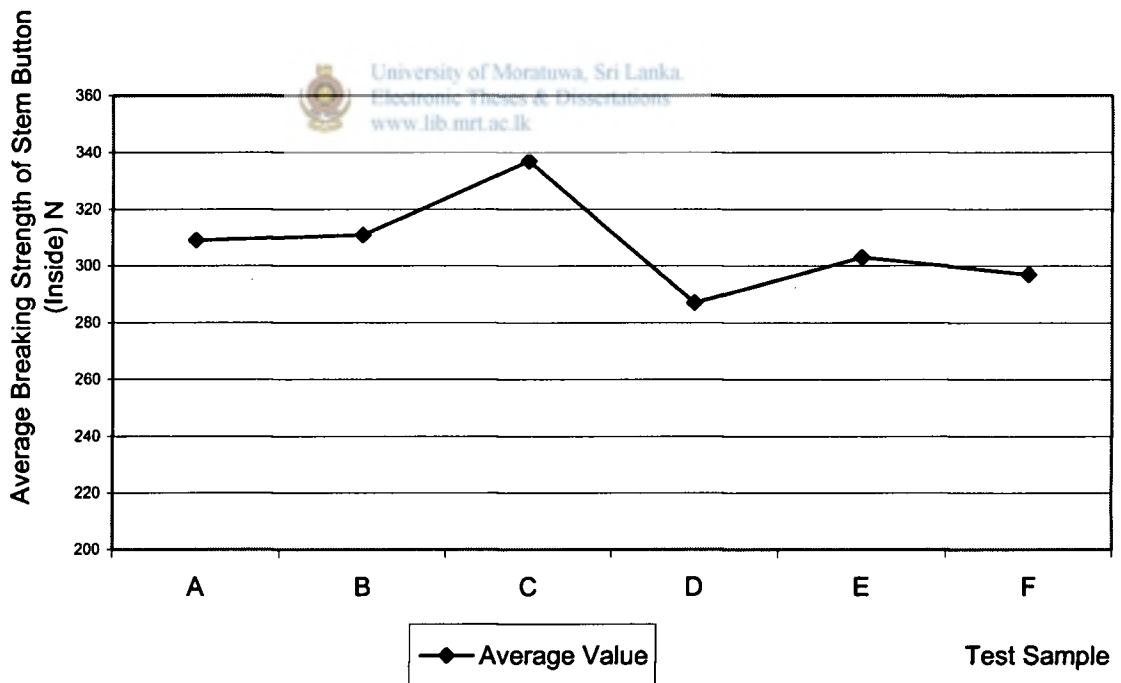

Figure 20 : Average breaking load of stem button - Inside



Table 7 : Breaking load of stem button- Outside

Breaking strengths of stem button (Out Side) N						
Test Sample	A	B	C	D	E	F
1	337	339	296	270	264	334
2	334	357	350	270	300	300
3	331	355	363	270	285	325
Average Value	334	350	336	270	283	319

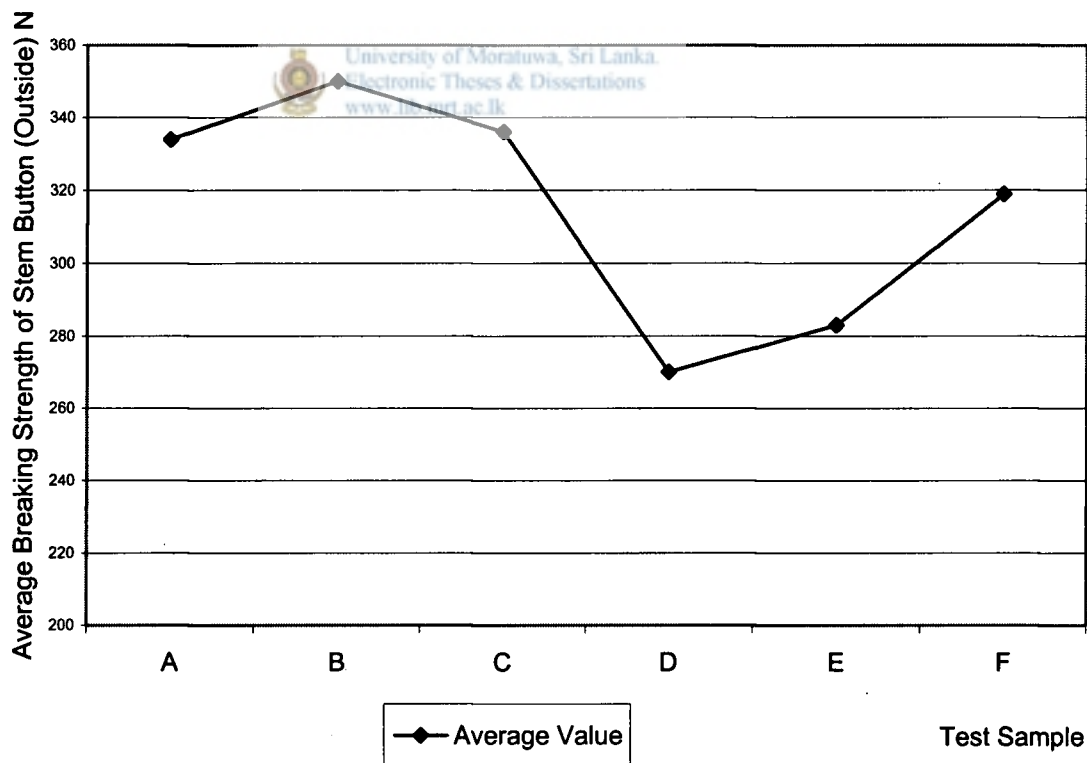

Figure 21: Average breaking load of stem button - Outside

Test result of tensile properties

Table 8 : Tensile strength of test compounds

Test Sample	Tensile strength (MPa)					
	A	B	C	D	E	F
1	13.3	14.3	14.8	13.6	12.4	13.7
2	13.0	12.7	14.1	14.6	12.3	13.7
3	11.4	12.8	14.3	14.8	11.6	11.8
4	14.9	15.0	11.0	14.1	14.4	12.1
Average Value	13.15	13.7	13.55	14.27	12.6	12.8



University of Moratuwa, Sri Lanka
Electronic Theses & Dissertations
www.lib.mrt.ac.lk

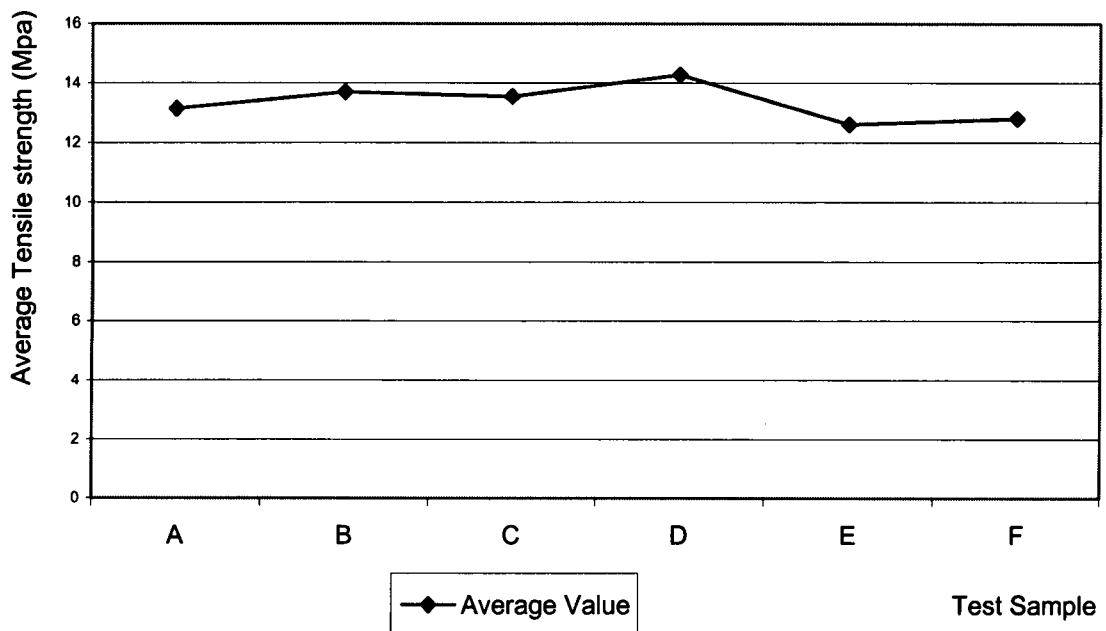

Figure 22 : Average tensile strength of test compounds



Table 9 : Modulus of test compounds

Test Sample	Modulus 300% (MPa)					
	A	B	C	D	E	F
1	8.8	8.4	8.2	8.2	8.2	8.7
2	8.4	8.6	9.3	8.1	8.5	8.3
3	8.1	8.7	7.7	8.1	9.1	8.2
4	8.9	9.3	8.7	8.1	8.5	8.3
Average Value	8.55	8.79	8.4	8.1	8.57	8.37

University of Moratuwa, Sri Lanka.
Electronic Theses & Dissertations
www.lib.mrt.ac.lk

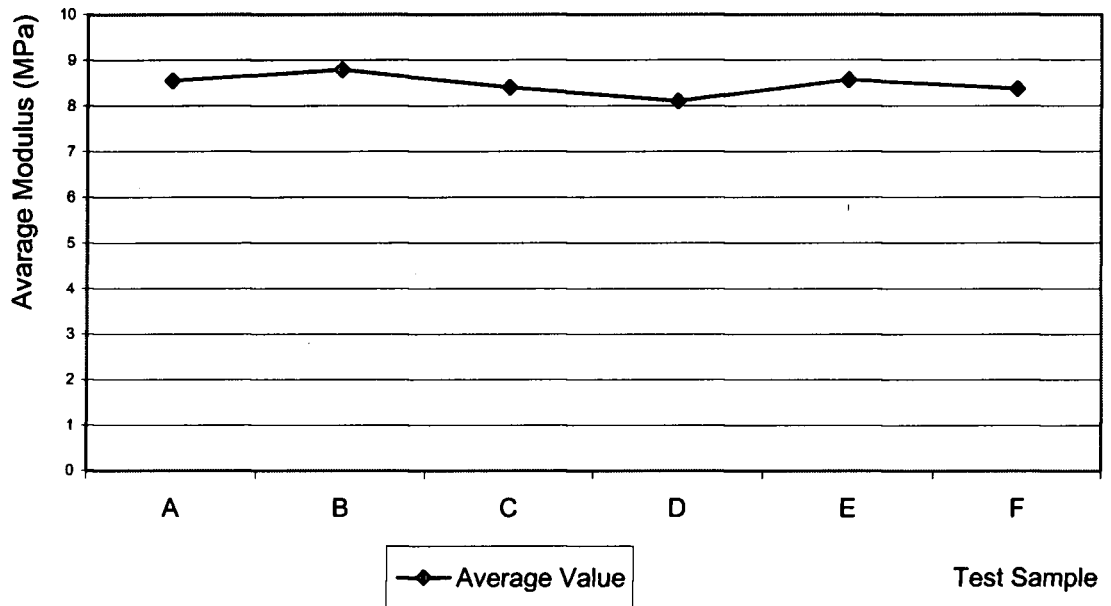

Figure 23: Average modulus of test compounds

Table 10 : Elongation at break of test compounds

Test Sample	Elongation %					
	A	B	C	D	E	F
1	400	435	435	425	375	412
2	415	450	400	425	360	425
3	415	450	425	450	350	400
4	550	535	375	425	390	400
Average Value	445	467.5	408	431.25	368.75	409.25

 University of Moratuwa, Sri Lanka.
 Electronic Theses & Dissertations
www.lib.mrt.ac.lk

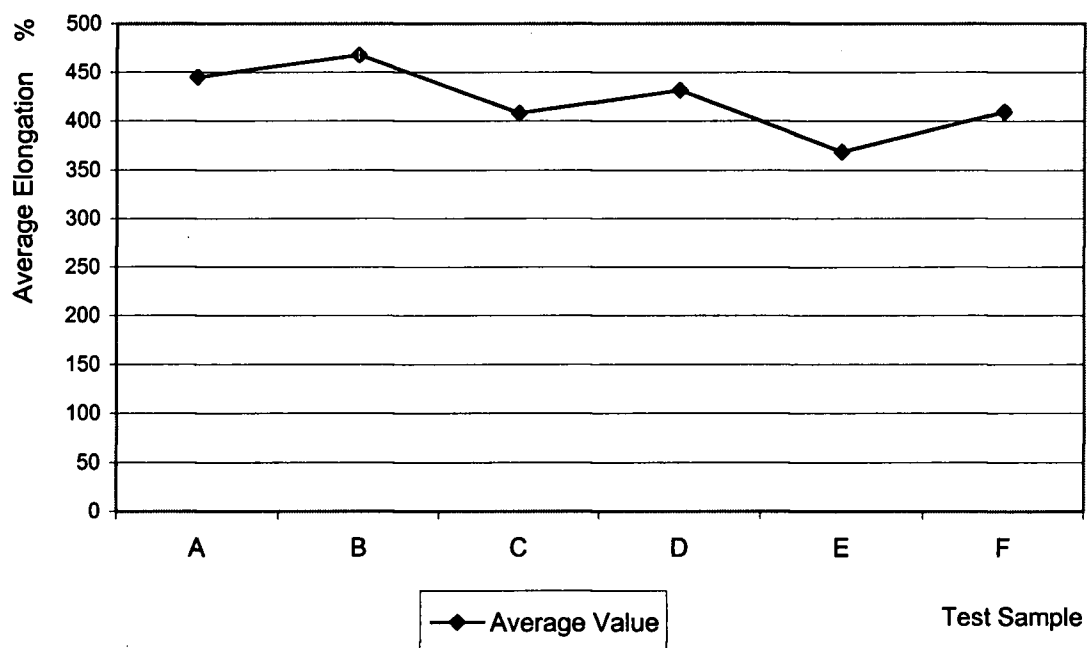

Figure 24 : Average elongation of test compounds

Table 11 : Hardness of test compounds

Test Sample	Hardness (IRHD)					
	A	B	C	D	E	F
1	63	64	60	64	62	60
2	62	62	61	61	63	61
3	64	63	62	61	63	62
Average Value	63	63	61	62	62.6	61

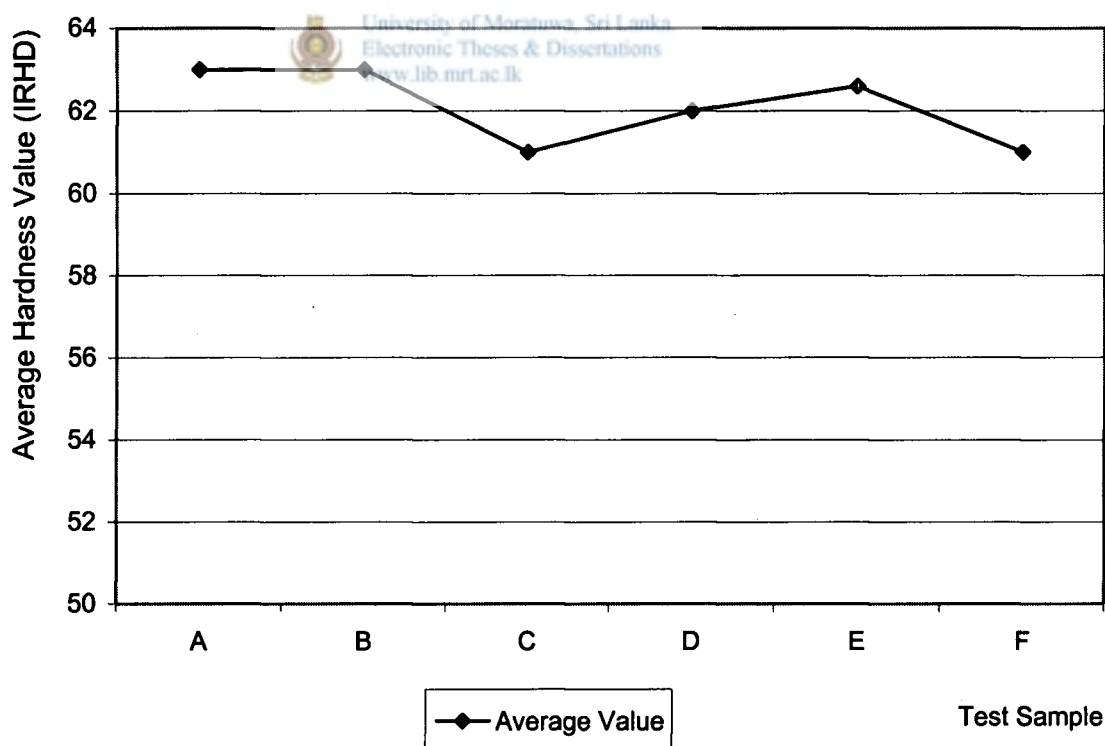

Figure 25 : Average hardness of test compounds



Ageing test results

Table 12 : Ageing 7 days at 70°C test results

	Ageing %					
	A	B	C	D	E	F
	49.5	48.1	54.2	65.4	45.7	42
	56	60.3	63	66.2	40.4	36.8
	45	50.4	57.2	56.8	35.3	47.3
Average	50.1	52.9	58.0	62.8	40.4	41.9

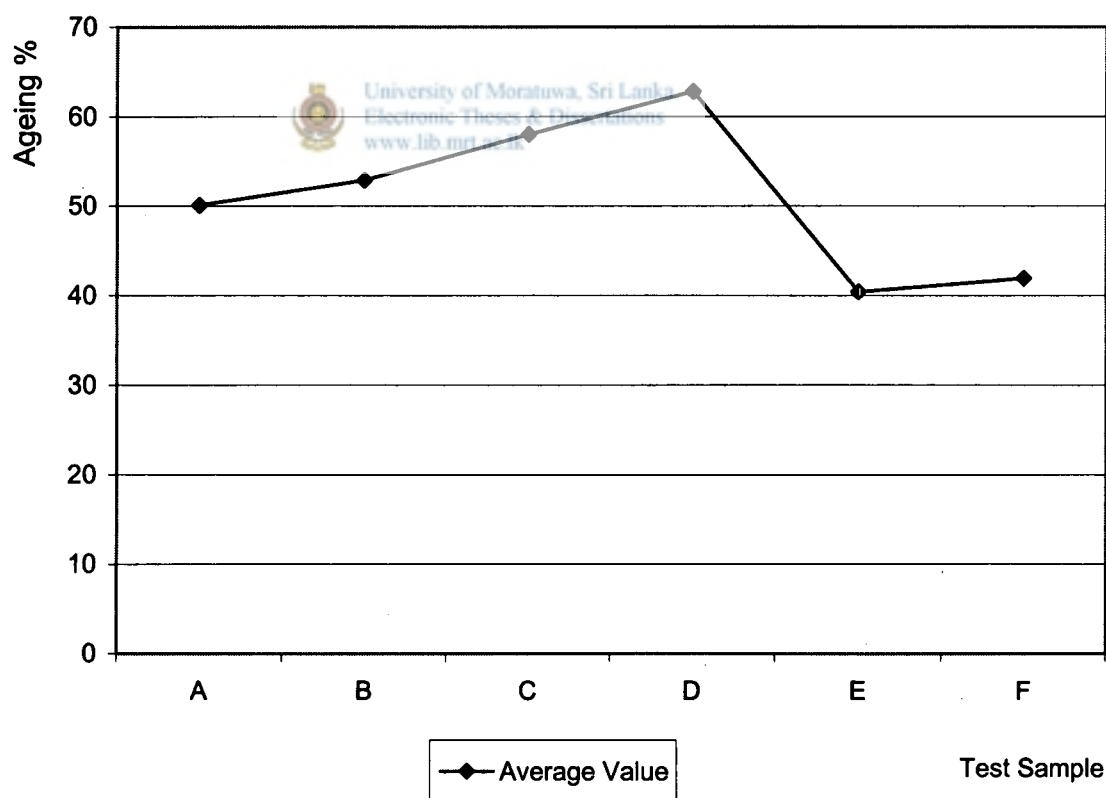

Figure 26 : Average ageing of test compounds

c) Visual Observation after 14 days exposure

- Sample A** - Severe bloom could be seen.
No bloom was observed in the covered area.
- Sample B** - Moderate bloom could be observed.
No bloom was observed in the covered area.
- Sample C** - Slight bloom could be observed.
No bloom was observed in the covered area.
- Sample D** - No bloom was observed in both
Covered and open area.
- Sample E** - No bloom.
- Sample F** - No bloom.



3.4 Discussion of the results

a). Processability test results

According to the values of minimum, maximum TS_2 and T_{90} , ABCD sample compounds are acting alike. But sample E compound is always deferent, comparing with them and sample F is in between sample E and ABCD.

Sample E has high min and max values and low TS_2 and T_{90} values. Therefore it's cure rate is very high. But sample F has a lower cure rate than sample E.

b). Physical properties test results

Physical test results of all compounds except elongation showed similarity in results meeting with company specifications.

Therefore it can be said, the antioxidant levels had no significant impact on the physical properties of compounds.

The elongation test results of sample E shows a reversion of it's value and it is not satisfied with the standard. Sample F has overcome this problem and it's elongation at break was acceptable with the standard.

c). Assessment of blooming

Analysis of observation of samples after 14 days exposure

Intensity of blooming reduced gradually from A to D with reduction of the phenolic antioxidant level in the exposed area. Covered areas of all samples were unaffected and no bloom was visible.

No bloom was observed in the exposed area of sample D. The lowest level of antioxidant used in this experiment was in sample D. But this formula cannot be recommended for production without considering the ageing behavior and it's results.

Sample E and F also showed no blooming with the introduction of ZDC as a secondary antioxidant, showed it's synergistic effect in the antioxidant system.

This behavior was the key observation that was used to conclude the experiment successfully.



University of Moratuwa, Sri Lanka
Electronic Theses & Dissertations
www.lib.mrt.ac.lk



3.4.1 Photos of Blooms

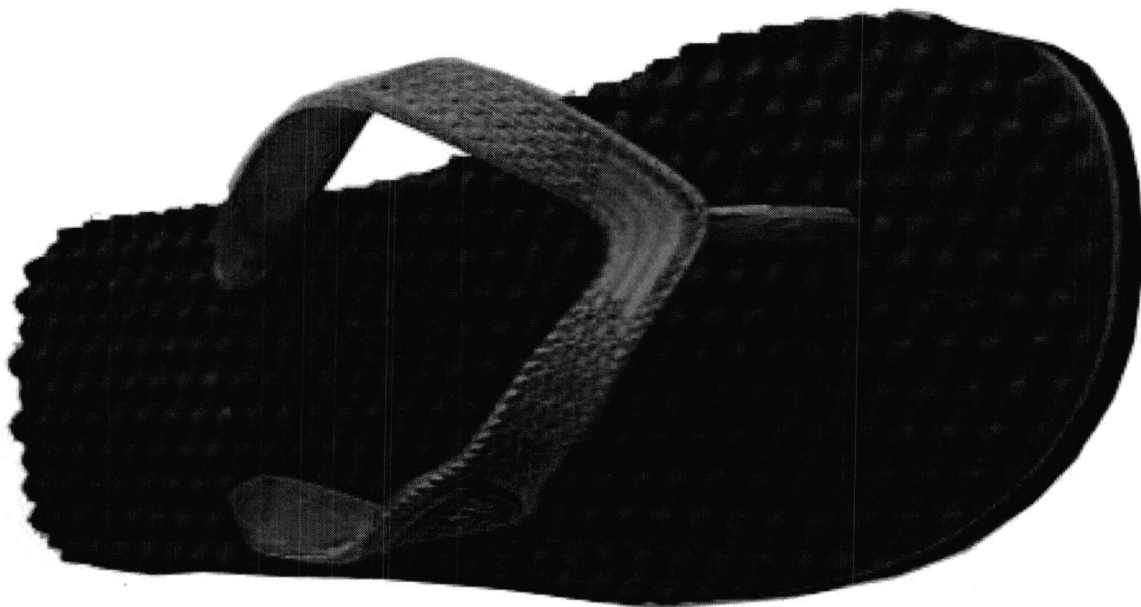

Figure 27 : Bloomed strap sample- 01



University of Moratuwa, Sri Lanka.
Electronic Theses & Dissertations
www.lib.mrt.ac.lk



Figure 28 : Bloomed strap sample- 02