



Proceedings of the 9th APTE Conference
6th - 8th August 2014, Mount Lavinia Hotel, Sri Lanka

**INCORPORATING FUNCTIONAL PERFORMANCE IN MIXTURE DESIGN OF
POROUS PAVEMENT**

Lei Zhang
Graduate Research Scholar
Dept. of Civil & Environmental Engineering
National University of Singapore
Singapore
Email: a0068326@nus.edu.sg

Ghim Ping Ong
Lecturer
Dept. of Civil & Environmental Engineering
National University of Singapore
Singapore
Email: ceeongr@nus.edu.sg

Tien Fang Fwa
Professor
Dept. of Civil & Environmental Engineering
National University of Singapore
Singapore
Email: ceefwatf@nus.edu.sg

ABSTRACT

Skid resistance and tire/road noise are critical functional elements of a modern pavement system and can affect roadway safety and environmental comfort. Although porous surface layer serves mainly as a functional course in most applications, the considerations on skid resistance and acoustic absorption in porous mixture design is inadequate in the existing specifications. Most current mixture design procedures assume that functional performances are adequate if volumetric and composition requirements are satisfied. However, the gap between design indices and in-situ performance should be bridged through thorough understanding of the mechanisms and relationships between them. This paper proposes an analytical framework to integrate skid resistance and tire/road noise performances into porous mixture design, based on numerical prediction models previously developed and validated by the authors. The framework takes account of the long-term effect, seasonal variation and temperature influence on skid number and sound pressure level. A functional performance index (FPI) is computed as the final output of the framework, denoting the quality of a porous mixture design with respect to its functional performance. A case study is then discussed to demonstrate the feasibility and capability of the proposed framework. With adequate knowledge on mixture properties and appropriate estimation on empirical parameters, this framework can help improve the quality of porous mixture design and enhance performance of the finished pavement.

Keywords: porous pavement, skid resistance, tire/road noise, mixture design, numerical simulation

1. INTRODUCTION

Conventional pavement design traditionally are focused on attaining adequate structural capacity and durability of bonded pavement layers, and to some extent, places less attention on ensuring that functional performance of pavement surfaces are attained. Pavements in modern transportation system serve various functions to ensure appropriate traveling quality (Mallick and El-Korchi 2013). Among all aspects of pavement functional performance, priority is often given to ensuring roadway safety, (which requires considerations to be made during pavement design to reduce traffic accident occurrences) and comfort (which is another crucial functional requirement and are often evaluated by road users' perception). Two essential aspects on improving roadway safety and comfort to road- and non-road-users are: (1) enhancing roadway safety by increasing wet-weather skid resistance and (2) improving environmental comfort by reducing tire/road noise. It is often difficult to deal with these two aspects simultaneously because of their contradictory dependencies on pavement surface texture.

For example, a pavement with sufficient (and durable) skid resistance performance often requires an increased surface texture, which may adversely affect tire/road noise performance.

Among the various innovative engineering measures, porous pavement is often found to be an effective and cost-efficient solution to improve wet pavement skid resistance as well as to control tire/road noise. Porous pavement consists of pavement structure whose surface layer contains a large amount of connected air voids, allowing rainwater to drain within the surface course. Porous asphalt and porous concrete are the major forms of porous pavement. The compacted porous surface is characterized by its high porosity, which can range up to 20% by volume (Anderson et al. 1998). The higher porosity results from the open gradation of its aggregate skeleton formed by mostly single-sized large particles. The absence of fine aggregates from the mix design results in air voids between large aggregates unfilled when stone-on-stone contact is achieved after compaction. High-viscosity modified asphalt or high-strength cement is often used to as a binder, ensuring sufficient structural integrity and durability. Such a porous layer is commonly laid on an impermeable base course to form an inner-drainage system with a finite thickness. It is noted that a successful porous system does not sacrifice pavement structural capacity.

Initially developed in the Unites States in the mid-twentieth century, porous pavement applications are primarily aimed to enhance traveling safety on high-speed road facilities. This objective is achieved by improving the wet-pavement skid resistance and preventing the occurrence of hydroplaning. It has been extensively reported that the skid resistance levels on porous pavements are generally higher than those on dense-graded asphalt or concrete pavements, and less speed-sensitive (Isenring et al. 1990; Kandhal and Mallick 1998; Liu et al. 2010). This advantage is a result of the combined effect of inter-connected air voids and coarser surface macrotexture, which allow free water to be quickly discharged from tire-pavement contact patch. With the rapid advancement of porous pavement technology, benefits of the use of porous pavements to improve environmental comfort and especially its capability to reduce tire/road noise are recognized (Gibbs et al. 2005; Abbott et al. 2010; Liu et al. 2010). This benefit was first investigated in Europe and has now become the main purpose of porous pavement application in European countries. It is believed that porous surface achieves noise reduction primarily through two mechanisms. First, the tire/road noise generation is reduced through lowering the effect of air pumping around the front and rear edges of contact patch. Second, reflection and scattering of sound wave in the pores of the porous layers result in sound energy absorption and dissipation (Neithalath et al. 2005).

Although porous course serves mainly as a functional layer in most porous pavement applications, consideration of the impact porous mixture design have on functional performances (i.e. skid resistance and noise) is seldom considered in existing specifications. To date, over 20 different design approaches have been developed across the United States (Putman and Kline 2012). All these methods focus on the selection of aggregate gradation and asphalt content to form a skeleton structure with a desired porosity. Taking the ASTM D7064M-08 standard (ASTM 2008a) as an example, the optimal grading is first chosen based on the voids in course aggregates. The content of modified asphalt is next determined by test results of air voids, draindown, abrasion loss and aging. A minimum air void content of 18% is specified. Laboratory permeability or porosity testing is optional, but no concerns are put on the skid resistance or acoustic absorption of the finished porous pavement. Porous asphalt design in UK is currently based on a recipe approach as specified in BS EN 13108-7 standard (BSI 2006). This standard defines aggregate gradation and binder grade for different application purposes, as well as the selection of additives and modifiers. The target binder content of 4.5% is considered as a balance between durability and permeability (The Highways Agency 1999). This method requires outflow tests being conducted after placement. The acceptable average relative hydraulic conductivity is in the range of 0.12 s^{-1} to 0.40 s^{-1} . Other clauses for appropriate drainage are issued as well, such as a nominal thickness of 50 mm and a minimum cross slope of 2.5%. However, all existing requirements are targeted at improving drainage capacity and there are neither direct guidelines on frictional and acoustic properties, nor are there explicit relationships between drainage capacity and functional performances.

It can be observed from the existing specifications that current porous mixture design procedures does not explicitly consider skid resistance and acoustic performances. It is basically assumed in existing practice that functional properties should be acceptable if volumetric and composition requirements are satisfied. This is not unexpected in current-day practice as complexities in understanding skid resistance and tire/road noise behaviors on porous pavements makes it difficult for engineers to implement some sort of formalized procedure in porous pavement mix design. The gap between in-laboratory design indices (for example aggregate gradation, porosity and permeability) and in-field functional performances (for example skid number and sound pressure level) should be bridged through thorough understandings in the mechanisms and theoretical relationships between friction and noise. This paper therefore attempts to approach this complex problem from a numerical perspective. An analytical framework is proposed to integrate skid resistance and tire/road noise performances into the procedures of porous mixture design, based on two previously developed numerical models. The framework considers long-term effects and seasonal variations in skid resistance and tire/road noise. A scalar named as the functional performance index (FPI) is computed as an output of the framework, indicating the functional quality of a porous mixture design. A hypothetical case study is demonstrated in this paper as well, illustrating the feasibility and capability of the proposed analysis framework.

2. ANALYSIS FRAMEWORK

It is very difficult to establish a trade-off between skid resistance and tire/road noise in terms of cost-benefit because of the lack of tools to evaluate them monetarily (Ahammed and Tighe 2010). It is also difficult to develop correlations between pavement functional properties and easily measured indices such as texture depth. It is even more complex to develop such correlations for porous pavements as the traditional definition of texture depth may be inappropriate for a porous surface and current texture measurement methods are often prone to errors when performed on porous pavements. As such, the selection of a proper porous mixture design is often a complex task, especially when both functional and structural performances are to be considered. There is hence a need for a practical guideline to define the desired minimum surface friction and maximum noise level for a newly constructed or rehabilitated pavement, as well as an analytical approach to predict the skid resistance and tire/road noise on the finished surface in the mixture design stage.

Figure 1 shows the proposed framework to consider wet-pavement skid resistance and tire/road noise in porous mixture design. Existing procedures specify methods to select material properties, aggregate gradation, asphalt content and additive usage to form a durable pore structure with a desired air void content. Using the specimens designed by existing procedures, some crucial characteristics of compacted porous mixture can be measured from various in-lab experiment. This include porosity, permeability, nominal aggregate size and characteristic pore size. These mixture properties determine the drainage capacity and acoustic absorption of porous pavement.

The workflow develops in two parallel tracks, one on skid resistance and the other on tire/road noise. A simplified pore network geometry model is established to reproduce the drainage capacity of a given thickness of designed mixture. The standard lock-wheel skidding test is then simulated on the simplified porous layer using a finite element model and the skid number at standard condition is predicted. The predicted skid number (SN_p) is compared with the required skid number (SN_r) derived from the design criteria on skid resistance performance. If SN_p is larger than SN_r , a skid resistance performance index (SPI) can be designated and the mixture design passes friction requirement. If not, one needs to adjust the aggregate gradation and/or asphalt content and redo the mixture design. On the other track, another simplified pore network model is developed to reproduce the acoustic absorption capacity of the same porous pavement. The sound pressure level in a standard CPX noise measurement is then predicted using a previously developed tire/road noise simulation model. The predicted sound pressure level (SPL_p) is compared with the allowable value (SPL_r) derived from design criteria on tire/road noise. If SPL_p is lower than SPL_r , the mixture design passes acoustic

requirement and an acoustic performance index (API) is appointed to it. When both criteria are satisfied, the particular mixture design is considered adequate to provide appropriate functional performance. In order to evaluate different qualified mixture designs, functional performance index (FPI) is finally calculated from linear superposition of SPI and API. The weighting factors α and β are project-specific and heavily depend on experts' subjective judgments. The critical components in this analysis framework are described in the following subsections.

2.1 Drainage Capacity Model and Skid Resistance Model

Computational fluid dynamics (CFD) method was used to develop numerical models reproducing the drainage capacity of a porous pavement surface and simulating the lock-wheel skidding test conducted on it in the authors' previous works (Zhang et al. 2012, 2013a). These models have been successfully used in the analysis of influential factors on skid resistance performance of porous pavement (Zhang et al. 2013b, c). The models are briefly described below, readers may refer to the above mentioned works for more details.

2.1.1 Simplified Pore Network Model in Drainage Capacity Simulation

Due to the complexity of porous mixture geometry, it is impractical to duplicate the actual structure of pore network in a numerical model. Although the permeability of a porous pavement is closely related to its porosity, using porosity alone to predict drainage capacity has been proved to be inadequate and misleading (Chuai 1998; Kuang et al. 2011). Therefore, other drainage-related parameters have to be considered, such as outflow time, clogging percentage and pore dimension. The pore geometry is simplified as a three-dimensional grid network structure with straight channels in all the longitudinal, transverse and vertical directions (*see* Figure 2). That is equivalent to spatially repeating a cubic pore element in the three directions. Two variables are needed to specify this network, namely the edge length of drainage channel cross section (denoted by a), and the distance between centres of two successive parallel channels (denoted by b). An iterative process (Zhang et al. 2012) considering the presence of closed pores and clogging effect was developed based on the constant-head or falling-head outflow tests to determine the two pore dimension variables. The resulted pore structure maintains the drainage capacity of the specific porous surface layer.

2.1.2 Lock-Wheel Skid Resistance Simulation Model

A three-dimensional finite element model to evaluate skid resistance on porous pavement surface has been developed, incorporating the drainage capability of porous surface layer into tire-pavement-fluid interaction based on the theories of structural mechanics and fluid dynamics. Figure 2 shows the major components of this numerical simulation model, namely pneumatic tire sub-model, fluid sub-model and porous pavement sub-model. The model simulates the standard lock-wheel skid test (ASTM 2006) by considering a smooth tire skidding on a flooded porous pavement at specific conditions. The sub-models are interconnected through fluid-structure interaction and tire-pavement contact. The relative motion frame of reference is adopted, where the pavement, water and air move towards the stationary tire at vehicle traveling speed.

The pneumatic tire sub-model is developed according to the standard smooth tire (ASTM 2008b). Tire walls are modeled by four-node finite strain shell elements with various homogeneous isotropic elastic material properties. These simplifications can significantly improve the computational efficiency and appropriately maintain the accuracy of tire behavior. Tire-pavement contact is assumed to follow the Coulomb's concept of friction. The pavement sub-model reproduces the drainage capacity of in-field porous pavement as well as provides a rigid surface for tire-pavement contact. Fluid behaviors are captured by Navier-Stokes equations in the fluid sub-model. The standard $k-\epsilon$ model is adopted to describe the fluid turbulence. Both water and air are considered by multiphase flow approach to more closely reproduce the actual tire-fluid-pavement interaction. Boundary conditions of fluid sub-model are shown in Figure 2.

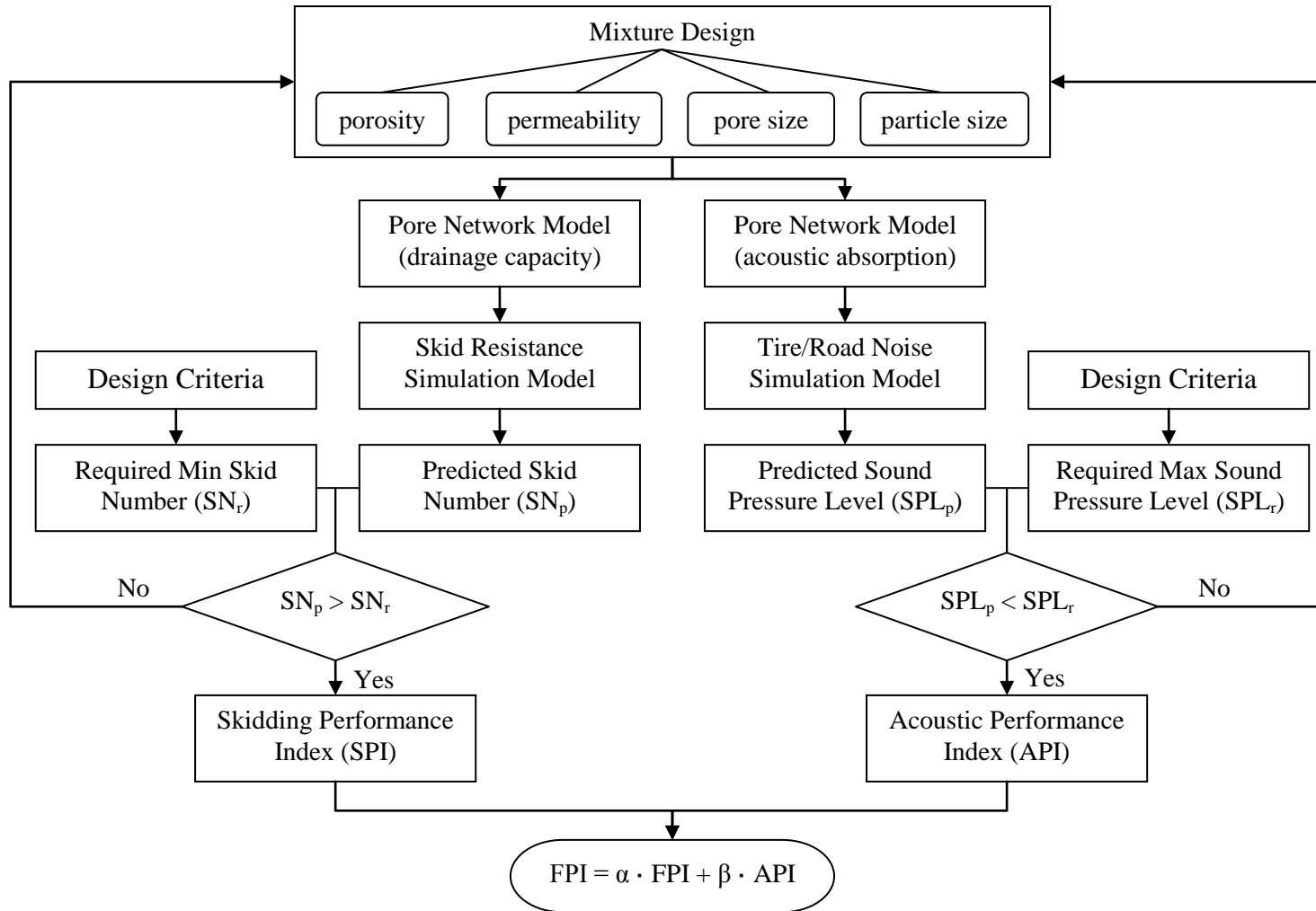

Figure 1: Analysis Framework to Integrate Frictional and Acoustic Performances into Porous Mixture Design

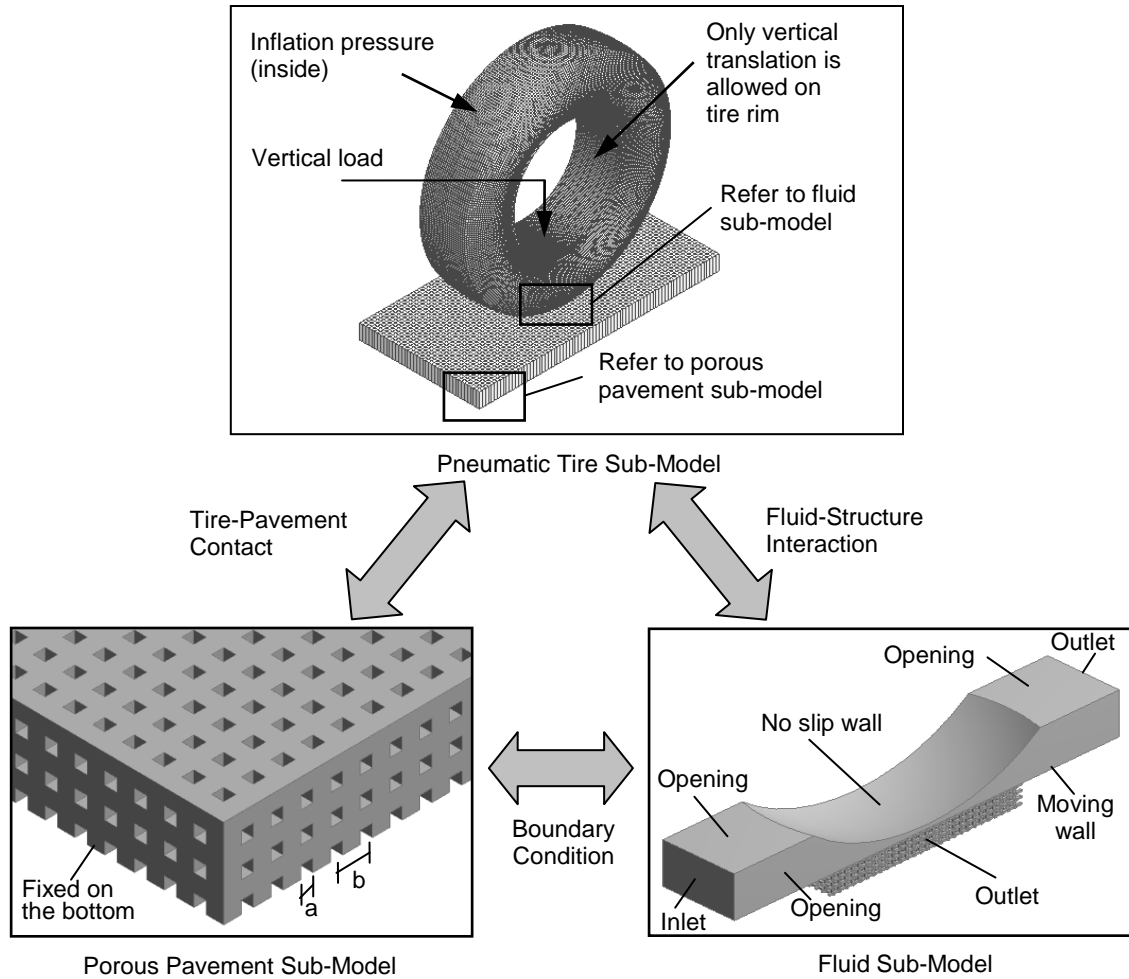

Figure 2: Skid Resistance Simulation Model for Porous Pavement

Fluid uplift force and drag force acting on tire tread are the two direct outputs from the skid resistance simulation model. Skid number at speed v (SN_v) is derived from these two values:

$$SN_v = \frac{\mu \cdot (F_z - F_{uplift}) + F_{drag}}{F_z} \times 100 \quad (1)$$

where F_{uplift} is the fluid uplift force, F_{drag} is the fluid drag force, F_z is the vertical wheel load and μ is the friction coefficient at wet tire-pavement interface. The model has been calibrated and validated against experimental data. The results show errors within ± 2 SN units, demonstrating the capability of this model to evaluate skid resistance performance of porous surfaces.

2.2 Acoustic Absorption Model and Tire/Road Noise Model

Finite element method (FEM) and boundary element method (BEM) were combined to develop a numerical model simulating the CPX noise measurement. A microstructural model was used to predict the acoustic absorption of porous mixture based on its pore structure parameters while an absorption penal approach was adopted to numerically represent the acoustic properties of porous pavement.

2.2.1 Microstructural Model in Acoustic Absorption Simulation

The complex pore structure within a porous pavement is assembled by simplified representative pores with a well-defined geometry in the microstructural model. The viscous effect and thermal motion are

separately considered for each single pore and corrected by a shape factor to take into account the pore structure complexity, such as tortuosity and pore size variation. The acoustic effect at macroscopic scale is generalized from the corrected single-pore results. This study adopts the model developed by Neithalath et al. (2005), which relates the acoustic absorption of porous mixture to its characteristic pore size, porosity and porous layer thickness.

Recognizing that air is cyclically compressed and expanded when acoustic waves propagate through porous mixture, Neithalath's model simplifies the pore network as a series of cylinders with varying diameter (see Figure 3). Each unit of pore structure consists of a pore (with diameter D_p and length L_p) and an aperture (with diameter D_a and length L_a). The characteristic pore size is defined by the median of all pore sizes larger than 1 mm, obtained from image analysis. The other dimension parameters are related to the pore size and porosity, and can be determined through iterative process or optimization algorithm. The effective porosity is maintained in the simplification of pore structure. The pore network is next modeled by an electro-acoustic analogy consisting of a series of resistors and inductors to simulate the acoustic behavior of porous pavement. Impedance in pores is modeled by an inductor, the value of which is a function of pore diameter. Aperture is modeled by a resistor and an inductor, representing the real and imaginary components of acoustic impedance, respectively. For a porous layer with a specific thickness composed by n cells, the acoustic impedance is determined by applying electro-acoustic analogy to all the cells. In the calculations, air density should be multiplied by a shape factor to take into account that the air in lateral pores appears to be "heavier" than the air in main pores due to different mechanisms in acoustic energy dissipation.

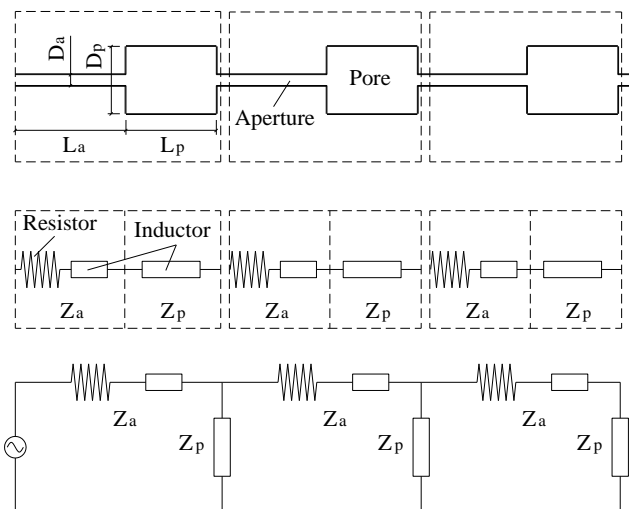

Figure 3: Electro-Acoustic Representation of Pore Structure

2.1.2 Close Proximity Tire/Road Noise Simulation Model

A numerical model capable to predict CPX tire/road noise on porous pavement has been developed by the authors. Three major steps are performed in a sequential manner. Tire deformations and stresses are firstly computed in dynamic rolling analysis. Natural frequencies and mode shapes of tire walls are next computed through modal analysis, and tire vibration characteristics are captured through mode superposition under pavement texture excitations. The tire wall vibrations are next input into the BEM acoustic model to estimate the sound field around the rolling tire.

The explicit dynamic scheme is adopted in the rolling tire analysis with the standing rotation frame of reference. The wheel is rolling under a specific load without horizontal translation, while the pavement moves towards the standing wheel at traveling speed. The pavement is assumed rigid and sufficiently long to make possible at least three revolutions during tire rotation. Frictional contact condition is defined at the tire-pavement interface. The analysis is divided into three load steps. In the first step,

uniformly distributed pressure is applied on the inner surface of tire walls to simulate tire inflation pressure. Then the vertical wheel load is gradually applied, pushing the tire against pavement surface. After establishment of static equilibrium, tire rotation is introduced through a horizontal translation velocity of pavement and a corresponding angular velocity of tire. Through the rolling tire analysis, deformations and stresses in tire walls are computed as intermediate solutions.

The natural frequencies and mode shapes are essential tire vibration properties. They are decided by the geometry and composition of tire itself. In tire modal analysis, the frequency response functions of nodes on tire walls are determined. Numerical approaches for modal analysis have been extensively explored (Brinkmeier and Nackenhorst 2008; Sabiniarz and Kropp 2010). Modal analysis is conducted on the deformed tire geometry obtained from the rolling tire analysis and the pre-stress condition is loaded onto the deformed mesh. Frictional contact is replaced by a bounded condition to eliminate nonlinearity in numerical formulation. Mode shapes at frequencies higher than 3000 Hz are neglected as low-order modes were found to be responsible for tire/road noise generation (Kropp et al. 2012). When a tire is rolling on a road, tire dynamic characteristics will create fluctuating forces that excite tire wall vibrations. In the various modeling approaches, mode superposition method (Bathe 1996) is widely used due to its easy implementation and high efficiency and is adopted in this paper to predict tire vibration resulting from pavement texture excitation.

Boundary element method is next used to simulate sound propagation on porous pavement with tire vibration as the generation source, and the proposed acoustic absorption model is integrated into the acoustic simulation. The deformed tire geometry generated from rolling tire analysis is imported into the BEM model with an acoustic mesh. Vibration velocities on tire surfaces obtained from the tire vibration analysis are then mapped onto the acoustic mesh. Porous pavement surface is modeled as an absorbent panel with specified frequency-dependant acoustic impedance. With such a configuration, the acoustic field around the rolling tire is computed. The sound pressure level at CPX microphone position is computed based on the simulation results:

$$L_p = 10 \cdot \log \left(\frac{p}{p_0} \right) \quad (2)$$

where L_p is the sound pressure level, p is the acoustic pressure at a specific position, and $p_0 = 20 \mu Pa$ is the standard reference sound pressure.

2.3 Design Criteria on Skid Number and Sound Pressure Level

It is important to understand that there are no identical design criteria universally applicable to all the projects. The terminal skid number and noise level (values at the end of pavement service life or before rehabilitation) should be determined based on project location, road classification, design speed, traffic mix, material properties and meteorological conditions. Design criteria on pavement functional performances (initial values at the beginning of pavement service) are then derived from the terminal requirements, taking account various long-term effects.

2.3.1 Minimum Skid Number Requirement

Although the lock-wheel skid number is considered as an important indicator of wet-weather traveling safety on high-speed roadways, none of the transportation agency in the United States have set an explicit legal minimum skid resistance requirement (Ahammed and Tighe 2010). This is not unexpected considering the difficulties in setting an absolute value of minimum skid number for the huge and complex road network, especially the litigation risk that may arise from skidding accidents. Tentative guidelines and recommendations, however, have been developed for desired minimum skid number by some agencies and researchers. Jayawickrama et al. (1996) surveyed 48 states on the practices of controlling skid resistance and suggested that the minimum skid number measured by



Proceedings of the 9th APTE Conference 6th - 8th August 2014, Mount Lavinia Hotel, Sri Lanka

ASTM E274 skid trailer should be 30 for low volume roads and 35 to 38 for high volume roads. Transportation Association of Canada applies a grading system to identify the low-friction section and initiate possible countermeasures. Improvement or maintenance is recommended if SN is less than 31 and there is an accident problem; maintain surveillance and take corrective action if SN is between 31 and 40; and no action is required if SN is larger than 40 (TAC, 1997). UK provides a more comprehensive requirement for the desired minimum friction levels based on the roadway category, geometric condition, pavement gradient and approaches. The investigatory level of the SCRIM friction coefficient ranges from 0.35 at 50 km/h for a motorway to 0.60 at 20 km/h for a sharp bend (Gargett 1990). Agencies in other counties have also developed various requirements on skid resistance performance according to their specific situations.

The desired minimum friction value could be used as the terminal skid resistance requirement. If the measurement follows ASTM E274 standard, the result obtained is terminal SN. It is understood that skid number declines with pavement age, mainly because of the polishing and abrasive effects of accumulative traffic loading. This long-term depreciation may be more severe on a porous pavement because of the clogging of pore network will significantly reduce its drainage capacity. Kowalski et al. (2009) observed the frictional performance of a porous friction course (PFC) section in a four year period. The skid number variation was found to be around 9 SN units during this period. Rezaei et al. (2011) developed an empirical model to predict skid resistance variation with traffic load on asphalt pavement. It was observed that skid number dropped faster at its early life and became stable after a certain amount of traffic loading. The overall skid number lost for PFC surface was about 20 SN units. Besides of pavement age, seasonal effects also influence the long-term variation of skid number. Temperature and precipitation are main reasons to the seasonal fluctuation. The common knowledge is that skid number decrease with increased temperature and its value is higher when measured after a rain. With a solid evaluation on the long-term effects caused by pavement aging and season influence, the desired minimum skid number for a new porous surface can be derived from the terminal SN value.

2.3.2 Maximum Noise Level Requirement

The concerns on tire/road noise are relatively new to pavement practitioners. There is no specification or guideline on acceptable maximum noise level available to date in pavement perspective, but some guidance on traffic noise levels at highway neighborhoods has been provided by the environmental agencies (Ahammed and Tighe 2010). In Federal Highway Administration technical advisory (Gee, 2005), tire/road noise has been recommended to be taken into consideration when selecting pavement surface types for highways and bridges. Despite the lack of official guidelines, several research studies attempted to explore the desirable pavement acoustic performance. Kuemmel et al. (2000) indicated that an appropriate surface should exhibit a maximum exterior noise pressure level of 83 dB(A) in pass-by measurement at 97 km/h. Rasmussen et al. (2008) suggested a target sound intensity level for PCC pavement surfaces between 100 and 105 dB(A) in on-board sound intensity measurement at 97 km/h. It should be noted that the acoustic performance of different pavement types may significantly differ from each other and the recommendations may not be applicable for every location. Therefore, the noise requirement of a porous pavement needs to be developed individually according to the public perception and noise abatement criteria. Moreover, the distance to nearby neighborhood should also be considered to connect public perception with close proximity noise level.

The acceptable maximum noise level can be used as the terminal acoustic requirement. If measured using CPX method, the result is denoted as terminal SPL. To determine the acceptable noise level for a newly constructed or rehabilitated pavement, the deterioration of its acoustic performance with time should be considered. This mainly results from the clogging of pore network, which reduces the sound absorption capacity of porous surface layer and increases the air pumping effect. Danish Road Institute measured tire/road noise on porous pavements for 7 years (Raaberg et al. 2001). The variation of noise level in this period was 5 to 6 dB(A). The temperature effect on tire/road noise should be considered in the derivation of design maximum noise level as well. Bueno et al. (2011) reported that increasing pavement temperature lead to a reduction in the CPX noise level assessed at a rate of 0.06 dB(A)/°C at

vehicle speed of 50 km/h. Mechanisms associated with both vibration and friction could be affected by temperature variations. Traffic composition is another factor taken into account, recognizing the fact that heavy vehicles commonly make more noise than light ones. With proper evaluations on the long-term effects, temperature influence and traffic composition, the acceptable maximum CPX noise level for a new porous surface can be derived from the terminal SPL.

2.4 Determination of SPI, API and FPI

The determination of skid resistance performance index (SPI), acoustic performance index (API) and functional performance index (FPI) is more subjective in nature. It depends more on the practitioners' experiences and experts' knowledge. All the three indexes are defined on a scale from 0 to 10. A score of 0 indicates an extremely poor performance, such as a skid resistance level concealing high accident potential or a tire/road noise level annoying large amount of residents along the roadway. A score of 10 indicates a perfect performance, such as a skid resistance level precluding skid-related accidents or a noise level maintaining most residents in the neighborhood comfortable. It is important to note that the evaluations of SPI and API are location-specific, considering pavement geometry, vehicle speed, climatic condition, surrounding environment and other factors. An integer number in the range of 0-10 is assigned to a mixture design according to the simulated results of skid number or sound pressure level. However, the relationships between SN_p and SPI or between SPL_p and API may not be linear.

FPI denotes a combined functional performance index covering both safety and noise consideration. It is a linear superposition of SPI and API with weighting factors α and β , respectively (*see* Figure 1). Factors α and β represent the relative importance of frictional and acoustic performances in assessment of overall functional performance, and their summation should be a unit. The values of α and β are determined based on the experts' judgment at this stage of study according to the purposes of porous surface application, and they are project-specific. The FPI value is calculated for each feasible mixture design (i.e. mixtures satisfy both requirements in skid resistance and tire/road noise). After comparison, the mixture with a high FPI value at a reasonable cost should be selected as the final design.

3. HYPOTHETIC CASE STUDY

The application of the proposed analysis framework is next demonstrated through a hypothetical case study. A tangent highway section is going to be rehabilitated using a porous asphalt overlay with the attempt to enhance skid resistance and reduce tire/road noise. The existing dense-graded surface is assumed to be impermeable and acoustically hard. The porous overlay will have a uniform thickness of 50 mm to preserve the geometric features of the old pavement. Three different mixture designs with an identical porosity of 20% are considered in the overlay design. There is no trial section available, so performance prediction have to be based on lab-measured parameters and numerical simulations.

Volumetric parameters and permeability values of the three mixtures are shown in Table 1. These parameters are used to determine the pore network model in skid resistance prediction using a method proposed by Zhang et al. (2012) and derive the acoustic absorption spectrum in noise evaluation using the microstructural model developed by Neithalath et al. (2005). Surface texture levels of compacted mixtures are derived from texture profile measured using laser profilometer. The results of acoustic absorption coefficient and texture profile level for each mixture are shown in Figure 4. Based on the parameters mentioned above, lock-wheel skidding test (ASTM 2006) and CPX noise measurement (ISO 2013) are simulated using the developed numerical models. All the experiment conditions are set according to the standard specifications. The results of SN_p and SPL_p can be obtained from numerical simulations. The design criteria of frictional and acoustic performances are determined based on the specific requirements of this project. The desired minimum skid number is 55 and the acceptable maximum noise level is 90 dB(A). The scales of SPI and API adopted in this case study are shown in Table 2. The weighting factors α and β take the value of 0.6 and 0.4 respectively, as it is assumed in

this case study that safety enhancement is considered to be more slightly important than noise reduction.

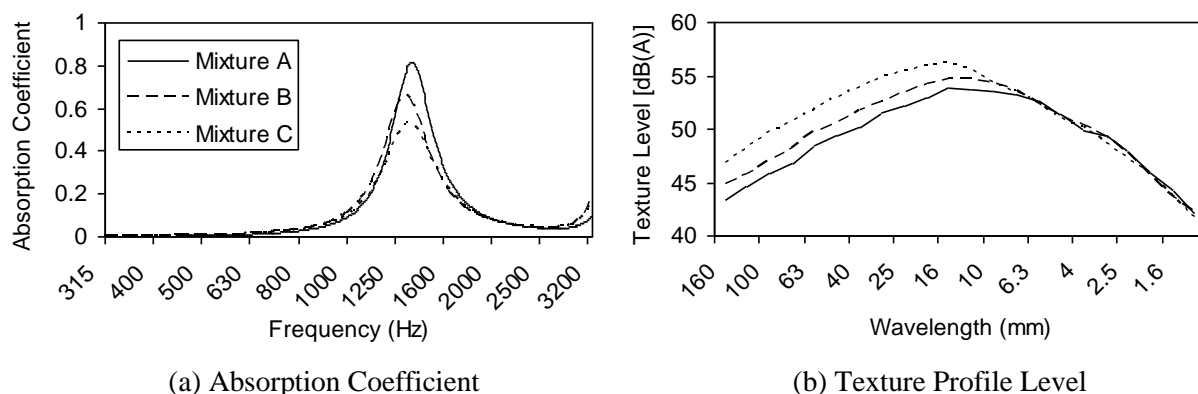

Figure 4: Acoustic Absorption Coefficient and Texture Profile Level of the Alternative Porous Mixture Designs

Table 1: Properties of the Alternative Porous Mixture Designs

	Aggregate Size (mm)	Pore Size (mm)	Porosity (%)	Permeability (mm ²)	Wet Friction Coefficient
Mixture A	12.5	3.6	20.1	4.5	0.65
Mixture B	16.0	4.6	20.0	4.8	0.64
Mixture C	19.0	5.5	20.3	5.3	0.61

Table 2: Scales of SPI and API Adopted in the Case Study

Scales	0	1	2	3	4	5	6	7	8	9	10
SN _p	< 55	55 - 57	57 - 59	59 - 61	61 - 63	63 - 65	65 - 67	67 - 69	69 - 71	71 - 73	> 73
SPL _p	> 90	89 - 90	88 - 89	87 - 88	86 - 87	85 - 86	84 - 85	83 - 84	82 - 83	81 - 82	< 81

Table 3: Analysis Results of the Alternative Porous Mixture Designs

	SN _p	SPL _p	SPI	API	FPI
Mixture A	63.3	86.7	5	4	4.6
Mixture B	62.5	88.3	4	2	3.2
Mixture C	59.8	91.3	3	0	1.8

The analysis results are shown in Table 3. It is seen that Mixtures A and B satisfied both requirements in skid number and noise level, while Mixture C fails in acoustic performance by providing a CPX sound pressure level higher than the design criterion. Between Mixtures A and B, the one with a larger PFI value and a reasonable material cost should be selected as the final mixture design. Therefore, if no much difference exists in material cost of the proposed mixture designs, Mixture A should be the best choice for this project.

4. SUMMARY

This paper has developed an analytical framework to incorporate considerations of functional performance into porous pavement mixture design. The framework is based on the prediction of skid resistance and tire/road noise level from lab-measured mixture properties using numerical simulation models. The predicted skid number and sound pressure level are next compared with the preset design criteria and those mixtures satisfied both the requirements are considered as candidates to final design. The functional performance index (FPI) is then calculated as a combination of skidding performance index (SPI) and acoustic performance index (API), which are derived from the predicted skid number and noise level under certain project-specific scales. The mixture with a higher FPI at a proper price should be considered as the appropriate design. A hypothetical case study is illustrated to show the feasibility and efficiency of this framework in practical applications of porous mixture design. Nevertheless, the determinations of SPI, API and FPI is still reliant on experts' experiences. Future research effort can be made to provide a scientific and objective interpretation of the developed indices.

REFERENCE

- Abbott, P.G., Morgan, P.A. and McKell, B., 2010. *A Review of Current Research on Road Surface Noise Reduction Techniques*. Transport Research Laboratory, Wokingham, UK.
- Ahammed, M.A. and Tighe, S.L., 2010. *Pavement Surface Friction and Noise: Integration into the Pavement Management System*. Canadian Journal of Civil Engineering, 37, 1331-1340.
- Anderson, D.A., Huebner, R.S., Reed, J.R., Warner, J.C. and Henry, J.J., 1998. *Improved Surface Drainage of Pavements*. Pennsylvania Transportation Institute, Pennsylvania State University.
- ASTM, 2006. *Standard Test Method for Skid Resistance of Paved Surfaces Using a Full-Scale Tire*. ASTM Standard E274-06, ASTM International, West Conshohochan, Pennsylvania.
- ASTM, 2008a. *Standard Practice for Open-Graded Friction Course (OGFC) Mix Design*. ASTM Standard D7064M-08, ASTM International, West Conshohochan, Pennsylvania.
- ASTM, 2008b. *Standard Specification for Standard Smooth Tire for Pavement Skid-Resistance Tests*. ASTM Standard E524-08, ASTM International, West Conshohochan, Pennsylvania.
- Bathe, K.J., 1996. *Finite Element Procedures*, Prentice-Hall, Englewood Cliffs, New Jersey.
- Brinkmeier, M. and Nackenhorst, U., 2008. *An Approach for Large-Scale Gyroscopic Eigenvalue Problems with Application to High-Frequency Response of Rolling Tires*. Computational Mechanics, 41(4), 503-515.
- BSI, 2006. *Bituminous Mixtures. Material specifications. Porous Asphalt*. BS EN 13108-7, British Standards Institute, London, United Kingdom.
- Bueno, M., Luong, J., Viñuela, U., Terán, F., and Paje, S.E., 2011. *Pavement Temperature Influence on Close Proximity Tire/Road Noise*, Applied Acoustics, 72(11), 829-835.
- Chuai, C.T., 1998. *Measurement of Drainage Properties of Porous Asphalt Mixtures*. Ph.D. thesis, National University of Singapore, Singapore.
- Gargett, T., 1990. *The Introduction of a Skidding-Resistance Policy in Great Britain*. Surface Characteristics of Roadways: International Research and Technologies. Edited by Meyer, W.E. and Reichert, J., American Society for Testing and Materials, Philadelphia, Pennsylvania, 30-38.
- Gee, K.W., 2005. *Surface Texture for Asphalt and Concrete Pavements*. FHWA Technical Advisory TA 5040.36, Federal Highway Administration, Washington, D.C.
- Gibbs, D., Iwasaki, R., Bernhard, R., Bledsoe, J., Carlson, D., Corbisier, C., Fults, K., Hearne, T., McMullen, J.K., Newcomb, D., Roberts, J., Rochat, J., Scofield, L. and Swanlund, M., 2005. *Quiet Pavement Systems in Europe*. Federal Highway Administration, Washington, D.C.
- Isenring, T., Koester, H. and Scazziga, I., 1990. *Experiences with Porous Asphalt in Switzerland*. Transportation Research Record, 1265, 41-53.
- ISO, 2013. *Acoustics - Method for Measuring the Influence of Road Surfaces on Traffic Noise - Part 2: Close-Proximity Method*. International Organization for Standardization, Geneva, Switzerland.



Proceedings of the 9th APTE Conference
6th - 8th August 2014, Mount Lavinia Hotel, Sri Lanka

- Jayawichrama, P.W., Prasanna, R., Senadheera, S.P., 1996. *Survey of State Practices to Control Skid Resistance on Hot-Mix Asphalt Concrete Pavements*. Transportation Research Record, 1536, 52-58.
- Kandhal, P.S. and Mallick, R.B., 1998. *Open Graded Asphalt Friction Course: State of the Practice*. National Center for Asphalt Technology, Auburn, Alabama.
- Kowalski, K., McDaniel, R.S., Shah, A. and Olek, J., 2009. *Long Term Monitoring of the Noise and Frictional Properties of Three Pavements: Dense-Graded Asphalt, Stone Matrix Asphalt, and Porous Friction Course*. Transportation Research Record, 2127, 12-19.
- Kropp, W., Sabiniarz, P., Brick, H., and Beckenbauer, T., 2012. *On the Sound Radiation of a Rolling Tyre*. Journal of Sound and Vibration, 331(8), 1789-1805.
- Kuang, X., Sansalone, J., Ying, G. and Ranieri, V., 2011. *Pore-Structure Model of Hydraulic Conductivity for Permeable Pavement*. Journal of Hydrology, 399, 148-157.
- Kuemmel, D.A., Sonntag, R.C., Jaeckel, J.R., Crovetto, J.A., Becker, Y.Z. and Satanovsky, A., 2000. *Using a Road Surface Analyzer to Explain Noise Characteristics of Portland Cement Concrete Pavement Surface Texture*. Transportation Research Record, 1716, 144-153.
- Liu, K.W., Alvarez, A.E., Martin, A.E., Dossey, T., Smit, A. and Estakhri, C.K., 2010. *Synthesis of Current Research on Permeable Friction Courses: Performance, Design, Construction, and Maintenance*. Texas Department of Transportation and Federal Highway Administration, Austin, Texas.
- Mallick, R.B. and El-Korchi, T., 2013. *Pavement Engineering: Principles and Practice*, Taylor & Francis, Boca Raton, Florida.
- Neithalath, N., Marolf, A., Weiss, J. and Olek, J., 2005. *Modeling the Influence of Pore Structure on the Acoustic Absorption of Enhanced Porosity Concrete*. Journal of Advanced Concrete Technology, 3(1), 29-40.
- Putman, B.J. and Kline, L.C., 2012. *Comparison of Mix Design Methods for Porous Asphalt Mixtures*. Journal of Materials in Civil Engineering, 24(11), 1359-1367.
- Raaberg, J., Schmidt, B. and Bendtsen, H., 2011. *Technical Performance and Long-Term Noise Reduction of Porous Asphalt Pavements*. Danish Road Institute, Denmark.
- Rasmussen, R.O., Whirledge, R., Turner, D., Light, R., Ferragut, T. and Wiegand, P., 2008. *Identifying Quieter Concrete Pavements Using On-Board Sound Intensity*. Transportation Research Board 87nd Annual Meeting Compendium of Papers. Transportation Research Board of the National Academies, Washington, D.C.
- Rezaei, A., Masad, E. and Chowdhury, A., 2011. *Development of a Model for Asphalt Pavement Skid Resistance Based on Aggregate Characteristics and Gradation*. Journal of Transportation Engineering, 137(12), 863-873.
- Sabiniarz, P., and Kropp, W., 2010. *A Waveguide Finite Element Aided Analysis of the Wave Field on a Stationary Tyre, Not in Contact with the Ground*. Journal of Sound and Vibration, 329(15), 3041-3064.
- TAC, 1997. *Pavement Design and Management Guide*. Transportation Association of Canada, Ottawa, Ontario.
- The Highways Agency, 1999. *Design Manual for Roads and Bridges: Pavement Design and Maintenance: Surfacing and Surfacing Material*, The Stationery Office, Norwich, UK.
- Zhang, L., Ong, G.P. and Fwa, T.F., 2012. *Three Dimensional Modeling of Porous Pavement Permeability Using a Simplified Pore Network Structure*. Proceedings of the 7th International Conference on Maintenance and Rehabilitation of Pavements and Technological Control, Auckland, New Zealand.
- Zhang, L., Ong, G.P. and Fwa, T.F., 2013a. *Developing an Analysis Framework to Quantify and Compare Skid Resistance Performances on Porous and Non-Porous Pavements*. Transportation Research Board 92nd Annual Meeting Compendium of Papers. Transportation Research Board of the National Academies, Washington, D.C.
- Zhang, L., Ong, G.P. and Fwa, T.F., 2013b. *Evaluating the Influence of Aggregate Size on Permeability of Porous Pavements Using Finite Volume Simulation*. International Journal of Pavement Research and Technology, 6(5), 520-526.



Proceedings of the 9th APTE Conference
6th - 8th August 2014, Mount Lavinia Hotel, Sri Lanka

Zhang, L., Ong, G.P. and Fwa, T.F., 2013c. *A Numerical Study on the Influence of Aggregate Size on Skid Resistance Performance of Porous Pavements*. Proceedings of the Eastern Asia Society for Transportation Studies, 9.