

**VIRTUAL SUPPORTS TO ANALYSE STATIC  
FLOATING STRUCTURES AND DYNAMIC SYSTEMS  
BY STATIC ANALYSIS SOFTWARE**

Harsha Suranga Kumarasinghe

149257C

Degree of Master of Science

Department of Chemical and Process Engineering

University of Moratuwa

Sri Lanka

July 2017

**VIRTUAL SUPPORTS TO ANALYSE STATIC  
FLOATING STRUCTURES AND DYNAMIC SYSTEMS  
BY STATIC ANALYSIS SOFTWARE**

Harsha Suranga Kumarasinghe

149257C

Thesis/Dissertation submitted in partial fulfillment of the requirements for the  
degree Master of Science

Department of Chemical and Process Engineering

University of Moratuwa

Sri Lanka

July 2017

DECLARATION

I declare that this is my own work and this thesis/dissertation does not incorporate without acknowledgement any material previously submitted for a Degree or Diploma in any other University or institute of higher learning and to the best of my knowledge and belief it does not contain any material previously published or written by another person except where the acknowledgement is made in the text.

Also, I hereby grant to University of Moratuwa the non-exclusive right to reproduce and distribute my thesis/dissertation, in whole or in part in print, electronic or other medium. I retain the right to use this content in whole or part in future works (such as articles or books).

Signature:..... Date:.....

The above candidate has carried out research for the Masters/MPhil/PhD thesis/  
Dissertation under my supervision.

.....

Supervisor Date

Mr. Kapila Peiris

.....

Supervisor Date

Dr. M. Narayana

## **Abstract**

When an object with high rigidity is subjected to free forces, moments and constrained forces, moments, stresses and strain will be formed in it. A support may be identified as a constrained which supplies forces/moment without any displacement.

In some cases although the constrains could balance the free forces/moments by and keep the system under equilibrium, the constraints cannot be keep a unique displacement (field). Therefore in such a case in an elemental analysis the solution for displacements will have many solutions conditions and in a computer where numerical methods (iterative) are used such solution will not be possible.

In this study a method is introduced to overcome this problem by the concept of ‘virtual constraints’ without changing the original stress-strain condition of the system.

System without adequate constraints will be known as floating system and dynamic systems (with high rigidity) with the application of reversed inertia forces could also be considered as floating system. Therefore such system also could be analyzed for stress-strain by proper introduction of artificial supports with the same software meant to analyses static system.

Keywords – Virtual supports, Floating system

## **ACKNOWLEDGEMENT**

At the very beginning of this research, I would like to express my gratitude to my immediate supervisor Mr. Kapila Peiris for giving his excellent support. His clear guidance paved me the way of finding correct direction to fulfill the project objectives. Moreover his pattern of logical thinking affected me to improve my thinking ability and it gave me a great support to complete the research activity. Further his theoretical knowledge motivated me to learn many theoretical aspects and it helped me to complete very successful chapter of theory in this research.

In addition to this I express my sincere thanks to Dr. Narayana, who gave me an excellent support to complete this research. Further I extended my sincere thanks to Dr. Narayana for his great service done as course coordinator in the course period.

Further I would like to extend my gratitude to management of the Loadstar private limited for giving their fully support to use Abaqus 6.14 software to my research work without any limitations.

Abstract	ii
ACKNOWLEDGEMENT	iii
List of abbreviations	ix
1. INTRODUCTION	1
1.1 Find stress field of a static body	1
1.2 solving stress-strain problems	3
1.2.1 Determining displacement field of no-constrain beam structure	4
1.2.2 Find displacement field of no-constrain CST plate element	8
1.2.3. Analysis of a simple un-constraints body by computer base FEA package	11
1.2 Objective	16
2. LITERATURE REVIEW	17
2.1 Studies done on virtual supports	17
2.2 Finite Element Method	22
2.3 Brief History	22
2.4 Computers for FEA	23
2.5 Finite Element and computers	23
2.6 Abaqus as general purpose software	25
2.7 Main steps of Abaqus analysis	25
2.7.1 Discretize the model	25
2.7.2 Element section properties	26
2.7.3 Material data	26
2.7.4 Loads module in Abaqus	26
2.7.4.7 Define pipe pressure load	27
2.8 Define boundary condition in Abaqus	28
2.8.1 XSYMM Symmetry about a plane $X = \text{constant}$ ( $U1 = UR2 = UR3 = 0$ )	28

2.8.2 YSYMM Symmetry about a plane $Y = \text{constant}$ ( $U_2 = UR_1 = UR_3 = 0$ )	28
2.8.3 ZSYMM Symmetry about a plane $Z = \text{constant}$ ( $U_3 = UR_1 = UR_2 = 0$ )	28
2.8.4 XASYMM Anti-symmetry about a plane with $X = \text{constant}$ ( $U_2 = U_3 = UR_1 = 0$ )	28
2.8.5 YASYMM Anti-symmetry about a plane with $Y = \text{constant}$ ( $U_1 = U_3 = UR_2 = 0$ )	29
2.8.6 ZASYMM Anti-symmetry about a plane with $Z = \text{constant}$ ( $U_1 = U_2 = UR_3 = 0$ )	29
2.8.7 PINNED Pinned ( $U_1 = U_2 = U_3 = 0$ )	29
2.8.8 ENCASTRE Fully built-in ( $U_1 = U_2 = U_3 = UR_1 = UR_2 = UR_3 = 0$ )	29
2.8.9 Defining velocity/angular velocity boundary condition	29
2.8.10 Defining acceleration/angular acceleration boundary condition	29
2.9 Depth in to Finite element analysis	29
2.9.1. Discretization and element selection	31
2.9.2 . Selection a displacement function	34
2.9.3. Define the strain/displacement and stress/strain relationship	34
2.9.4. Derive element stiffness matrix and equations	34
2.9.5 Assembly the element equations to obtain the global or total equations	37
2.9.6 solve for the unknown degree of freedom or generalized displacement	40
2.9.7 solve for the element stress and strain	41
2.9.8 Interpret the results	41
2.10 Derivation of the stiffness matrix for a bar element in a local coordinates	41
2.11 Derivation of the constant-strain triangular element stiffness matrix and equation	44
2.12 Cofactor method (Adjoining method) to determine the inverse of a matrix	49
2.13 Equation of elasticity	49

2.13.1 differential equation for equilibrium	49
2.13.2 Strain/Displacement and compatibility equations	51
2.13.3 Stress/strain relationship	53
3. INTRODUCTION OF VIRTUAL CONSTRAINTS	55
3.1 Floating structure	55
3.2 identification of floating, non-floating constraints by kinematics method	55
3.3 identification of floating, non-floating constraints by static method	56
3.3.1 Use virtual support to analyses roof structure of Kulasinghe auditorium in nerd center	61
3.4 Analyzing of a dynamic system with virtual supports	69
3.4.1 Analyzing of a rotating disc with virtual supports	70
3.4.1.1 Calculation of centrifugal force and tangential force	71
3.4.2 Stress-strain analysis of a wind blade	80
3.4.2.1 Determine $f_i$ from dynamics	81
3.4.2.2 Apply reversed inertia forces at the nodes	84
3.4.2.3 Apply virtual constraints	85
3.4.2.4 Analysis the system	86
3.4.2.5 Reaction Moment around Y axis of Virtual support	87
4. CONCLUSION	88
References	90
Appendix	94



## List of Figures

Figure 1: Stress tensor on an infinitesimal element	1
Figure 2: AB and BC beam structure	4
Figure 3: Nodal forces on the model	4
Figure 4: Nodal displacement on the model	5
Figure 5: Local forces and displacement of elements	5
Figure 6: Displacement vectors of CST elements	8
Figure 7: Schematic diagram of un-constrained beam	11
Figure 8: Error message in Abaqus output	11
Figure 9: Error message in ANSYS output	12
Figure 10: Error message of Nastran solver	12
Figure 11: Error message of FEmap solver	13
Figure 12: error message in Strand7 solver	13
Figure 13: Error message in SolidWorks simulation	14
Figure 14: Rigid foundation with no supports	17
Figure 15: Flow chart followed to get unique thermal stress without DBC s	19
Figure 16: Hydrostatic pressure on the object	20
Figure 17: FE simulation result	20
Figure 18: procedure to remove rigid body motion from deformation result solved without DBCs	21
Figure 19: Line element used in FEA	31
Figure 20: Plate element used in FEA	33
Figure 21: 3D elements used in FEA	33
Figure 22: Axisymmetric elements used in FEA	33
Figure 23: linear spring element	35
Figure 24: virtual displacement applied on the particle	37
Figure 25: Two spring assembly	37
Figure 26: Local displacement of beam	42
Figure 27: Nodal forces applied in local direction	42
Figure 28: displacement in a CST element	44
Figure 29: stress tensors on plane element	49

Figure 30: stress elements in three dimensional case	50
Figure 31: differential element before and after deformation	51
Figure 32: Deformation of 3D element for tensile stress in x direction	53
Figure 33: Virtual supports on a body	57
Figure 34: Roof of Kulasinghe auditorium	61
Figure 35:FEA model of structure	62
Figure 36: Mesh on the model	63
Figure 37: boundary condition on the model	64
Figure 38: Virtual supports on the roof	65
Figure 39: Loading on the structure	66
Figure 40: Von misses stress developed on the structure	67
Figure 41: Reaction force in X direction of virtual constraint	68
Figure 42: Reaction force in Z direction of virtual constraint	68
Figure 43: Reaction Moment around Y axis of virtual constraint	69
Figure 44: Reversed inertia forces on an object	69
Figure 45: Force on a rotating disc	70
Figure 46: Center of gravities of first segment	72
Figure 47: Reverse inertia forces on the disc	74
Figure 48: Boundary condition on the rotating disc	75
Figure 49: virtual supports to the disc	76
Figure 50: Von misses stress of rotating disc	77
Figure 51: Reaction force in X direction of virtual constraint	78
Figure 52:Reaction force in Z direction of virtual constraint	78
Figure 53:Moment around in Z axis of virtual constraint	79
Figure 54:kinematics of wind blade	80
Figure 55: Constraint on wind blade	81
Figure 56: Wind force on the FEA model	82
Figure 57: drag forces on the wind blade	83
Figure 58: reversed inertia forces on the model	84
Figure 59: Virtual support on the model	85
Figure 60: Stress analysis of wind blade at static mode	86
Figure 61: Reaction moment around Y axis of virtual constraint	87

Figure 62: Kinematics on wind blade 94

### **List of Table**

Table 1: Parameters of the rotating disc 71

Table 2: Calculation of inertia forces 73

### **List of abbreviations**

FEA	Finite Element Analysis
FEM	Finite Element Method
CFD	Computational Fluid Dynamics
AMS	Automatic Multi-level Sub structuring eigen solver
CAE	Complete Abaqus Environment
MPE	Minimum potential Energy theorem
CST	Constant Strain Triangular
NERD	National Engineering Research and Development Center
DBC	Displacement Boundary Condition

# 1. INTRODUCTION

## 1.1 Find stress field of a static body

When a body is subjected with internal and external forces, stress-strain analysis can be done by applying Newton's second and third laws, stress strain or shear relationship of the material and geometric compatibility. When the compatibility is considered, internal material compatibility and external boundary conditions are applied. External forces on a body could be forces/moments acting through constrains or forces/movements acting freely on the body.

When it is considered an infinitesimal part, there are 6 stress components at any point. Out of them, three stresses are normal stresses and other three stresses are shear stresses. Normal stresses are named as  $\sigma_x, \sigma_y$  and  $\sigma_z$ . Shear stresses are named as  $\tau_{xy}, \tau_{yz}$  and  $\tau_{xz}$ .

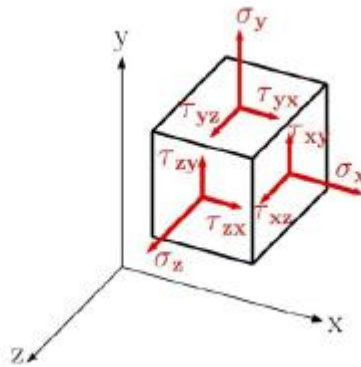

Figure 1: Stress tensor on an infinitesimal element

If the body forces are  $X_b, Y_b$  and  $Z_b$  in X, Y and Z directions respectively, by applying Newton's second law [1],[2] following equations are obtained.

$$\left. \begin{aligned} \frac{\partial \sigma_x}{\partial x} + \frac{\partial \tau_{yx}}{\partial y} + \frac{\partial \tau_{zx}}{\partial z} + X_b &= 0 \\ \frac{\partial \sigma_y}{\partial y} + \frac{\partial \tau_{xy}}{\partial x} + \frac{\partial \tau_{zy}}{\partial z} + Y_b &= 0 \\ \frac{\partial \tau_{xz}}{\partial x} + \frac{\partial \tau_{yz}}{\partial y} + \frac{\partial \sigma_z}{\partial z} + Z_b &= 0 \end{aligned} \right\} (1)$$

When the displacements of the point are U, V and W, in X,Y and Z direction respectively, strains are written as,

$$\varepsilon_x = \frac{\partial u}{\partial x}$$

$$\varepsilon_y = \frac{\partial v}{\partial y}$$

$$\varepsilon_z = \frac{\partial w}{\partial z}$$

Then shear strains are written as,

$$\gamma_{xy} = \frac{\partial u}{\partial y} + \frac{\partial v}{\partial x}$$

$$\gamma_{xz} = \frac{\partial u}{\partial z} + \frac{\partial w}{\partial x}$$

$$\gamma_{yz} = \frac{\partial v}{\partial z} + \frac{\partial w}{\partial y}$$

Then for isotropic linear elastic materials, relationship can be written for the element using Hooke's law for the three dimensional cases as follows [1], [3].

$$\begin{Bmatrix} \sigma_x \\ \sigma_y \\ \sigma_z \\ \tau_{xy} \\ \tau_{xz} \\ \tau_{yz} \end{Bmatrix} = E/(1+\nu)(1-2\nu) \begin{bmatrix} (1-\nu) & \nu & \nu & 0 & 0 & 0 \\ \nu & (1-\nu) & \nu & 0 & 0 & 0 \\ \nu & \nu & (1-\nu) & 0 & 0 & 0 \\ 0 & 0 & 0 & (1-2\nu)/2 & 0 & 0 \\ 0 & 0 & 0 & 0 & (1-2\nu)/2 & 0 \\ 0 & 0 & 0 & 0 & 0 & (1-2\nu) \end{bmatrix} \begin{Bmatrix} \varepsilon_x \\ \varepsilon_y \\ \varepsilon_z \\ \gamma_{xy} \\ \gamma_{xz} \\ \gamma_{yz} \end{Bmatrix}$$

Now due to above relationships, if the strain field is known, stress field could be found. For anisotropic and/or, linear/nonlinear materials more complex relations are available for stresses and strain. With the above relations viz equations derived using Newton's 2<sup>nd</sup> and 3<sup>rd</sup> law, kinematics relations between displacements and strains, stress-strain relations related with material properties and compatibility equations (including boundary conditions) theoretically it is possible to determine stress-strain of a system subjected to external loadings and constraints. But it is almost impossible to derive exact (close form) solutions for most of the cases.

## 1.2 solving stress-strain problems

Stress and strain can be formed in a body or structure after body or structure is subjected to forces, moments and constrains. If the displacement field of each point of the structure is known, by using equations (1), stress and strains can be calculated. However these equations can be used to solve system with simple geometries. When the geometry becomes complex, these equations can't be applied directly. In such cases, technique called Finite Element Analysis (FEA) or Finite Element Method (FEM) is used to find forces/moments, stress/strain and displacement and rotation of the system.

In FEA, basically form a matrix equation, as shown below.

$$\{F\} = [K]\{d\}$$

Here matrix  $\{F\}$  is known as the forces and moment matrix and it represents all the forces and moments of the system.  $\{d\}$  is known as the displacement and rotational matrix and it represents the nodal displacement and nodal rotation of the system.  $[K]$ ; global stiffness matrix includes the nodal co-ordinates, geometry parameters and material properties of the structure or body. In FEA solution method, simultaneous equations are solved by Gaussian elimination method or iterative method. When large systems are solved by computers, it is used iterative method.

But there are some situations, where constrains or supports are not rigidly fixed with reference to globe eventhough structure is in equilibrium with external forces/moments. In these cases displacement field of the structure is ambiguous or for the same force and moment system, there are infinite displacement fields. When the stress/strain equations are written to such kind of system, it can be shown that global stiffness matrix is singular and displacements field can't be solved. When the displacement field of this kind of system is found by manual calculation, it is always given as a variable of one unknown displacement or unknown displacements. But when this kind of system is analyzed by a computer package, the computer package can't find the displacement field due to unavailability of supports or lack of supports [4].

In order to clarify this situation, consider the scenario below.

### 1.2.1 Determining displacement field of no-constrain beam structure

Following structure consists of three beams named AB, BC and AC. They are connected at point A, B and C by pin joints. This system has no constraints. But at point A, B and C, three equilibrium  $F_A, F_B$  and  $F_C$  forces are applied respectively. As figure 2 shows, under these three forces system is equilibrium. Stiffness, Length and the cross section area of the beams are  $E, L$  and  $A$  respectively. Global coordinates system is defined as figure 2. Angle of AB, BC and AC beams with X axis are  $\alpha, \beta$  and  $\gamma$  respectively.

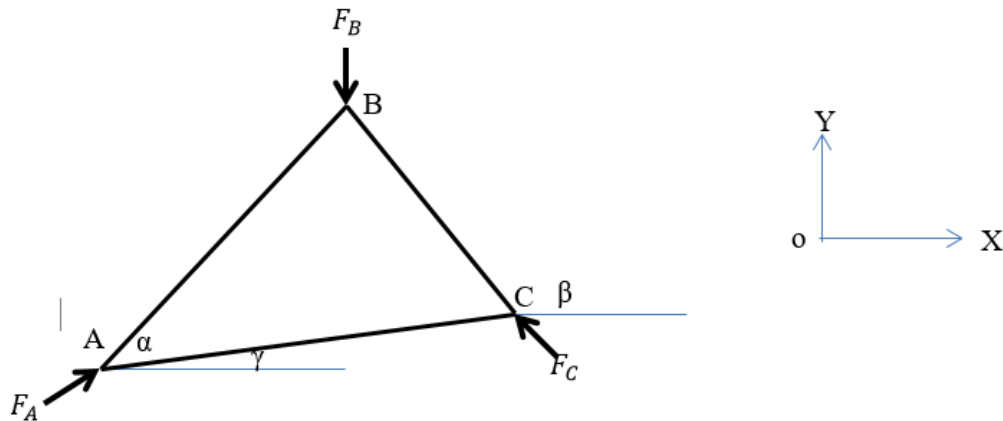

Figure 2: AB and BC beam structure

System is now discretized to element 1, 2 and 3. Nodes 1, 2 and 3 are marked on point A, B and C. Reaction forces at point A, B and C are  $F_{1x}, F_{1y}, F_{2x}, F_{2y}, F_{3x}$  and  $F_{3y}$  respectively.

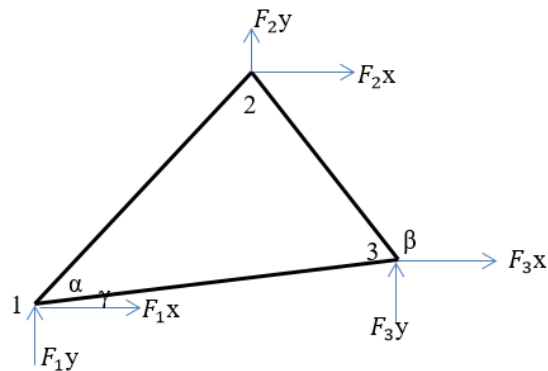

Figure 3: Nodal forces on the model

Displacement of nodes 1,2 and 3 are  $D_{1x}$ ,  $D_{1y}$ ,  $D_{2x}$ ,  $D_{2y}$ ,  $D_{3x}$  and  $D_{3y}$  respectively.

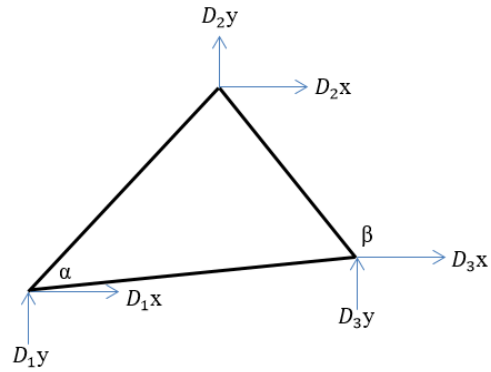

Figure 4: Nodal displacement on the model

Now structure is separated as beam AB,BC and beam AC. Local reaction forces and local displacements are marked as follows.

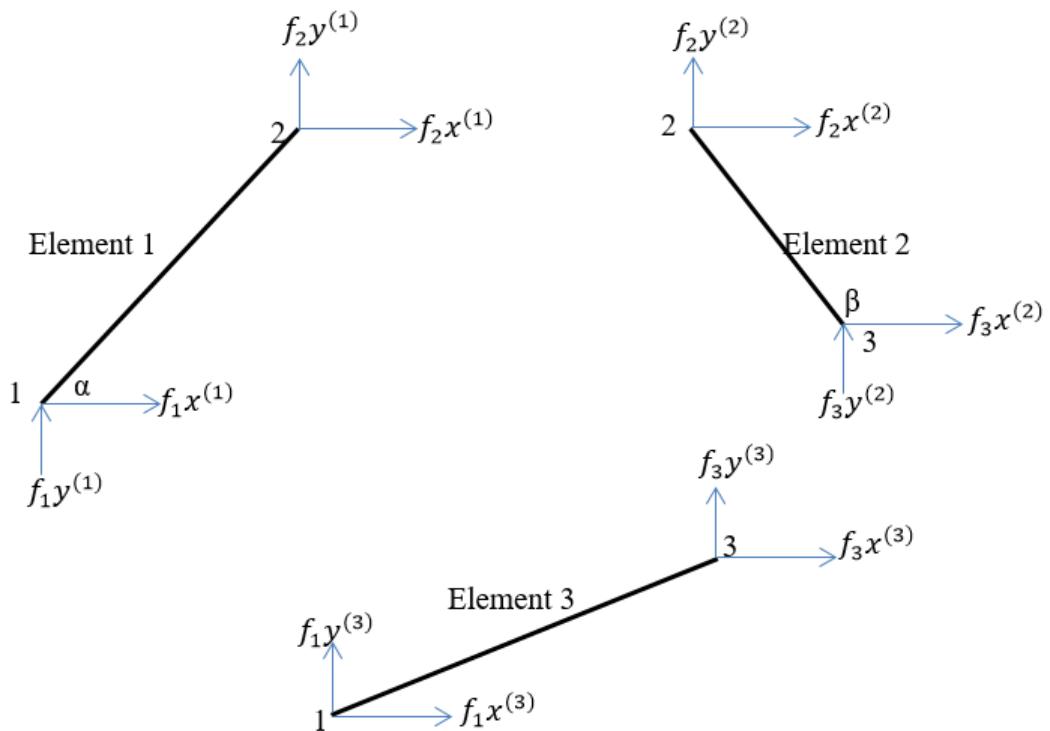

Figure 5: Local forces and displacement of elements

$f_{1x}^{(1)}$ ,  $f_{1y}^{(1)}$ ,  $f_{2x}^{(1)}$ ,  $f_{2y}^{(1)}$  are local nodal forces in element 1.



$f_2x^{(2)}, f_2y^{(2)}, f_3x^{(2)}, f_3y^{(2)}$  are local nodal forces in element 2.

$f_1x^{(3)}, f_1y^{(3)}, f_3x^{(3)}, f_3y^{(3)}$  are local nodal forces in element 3.

$d_1x^{(1)}, d_1y^{(1)}, d_2x^{(1)}, d_2y^{(1)}$  are local nodal displacement of element 1.  $d_2x^{(2)}, d_2y^{(2)}, d_3x^{(2)}, d_3y^{(2)}$  are local nodal displacement of element 2.  $d_1x^{(3)}, d_1y^{(3)}, d_3x^{(3)}, d_3y^{(3)}$  are local nodal displacement of element 3. Then,

$$\left. \begin{aligned} f_1x^{(1)} + f_1x^{(3)} &= F_1x \\ f_1y^{(1)} + f_1y^{(3)} &= F_1y \\ f_2x^{(1)} + f_2x^{(2)} &= F_2x \\ f_2y^{(1)} + f_2y^{(2)} &= F_2y \\ f_3x^{(2)} + f_3x^{(3)} &= F_3x \\ f_3y^{(2)} + f_3y^{(3)} &= F_3y \end{aligned} \right\} (2)$$

Further, for the nodal displacement following relationship is written.

$$\left. \begin{aligned} d_1x^{(1)} = d_1x^{(3)} &= D_1x \\ d_1y^{(1)} = d_1y^{(3)} &= D_1y \\ d_2x^{(1)} = d_2x^{(2)} &= D_2x \\ d_2y^{(1)} = d_2y^{(2)} &= D_2y \\ d_3x^{(1)} = d_3x^{(2)} &= D_3x \end{aligned} \right\} (3)$$

Let  $\cos(\alpha) = c_1, \sin(\alpha) = s_1, \cos(180 - (\beta)) = -\cos(\beta) = -c_2$  ,  $\sin(180 - (\beta)) = \sin(\beta) = s_2$  and  $\cos(\gamma) = c_3, \sin(\gamma) = s_3$ ,

According to the equation 23 in section 2.10, for element 1 following relationship can be written.

$$\begin{Bmatrix} f_1x^{(1)} \\ f_1y^{(1)} \\ f_2x^{(1)} \\ f_2y^{(1)} \end{Bmatrix} = AE/L \begin{pmatrix} c_1^2 & c_1s_1 & -c_1^2 & -c_1s_1 \\ c_1s_1 & s_1^2 & -c_1s_1 & -s_1^2 \\ -c_1^2 & -c_1s_1 & c_1^2 & c_1s_1 \\ -c_1s_1 & -s_1^2 & c_1s_1 & s_1^2 \end{pmatrix} \begin{Bmatrix} d_1x^{(1)} \\ d_1y^{(1)} \\ d_2x^{(1)} \\ d_2y^{(1)} \end{Bmatrix} \quad (4)$$

Similarly to element 2

$$\begin{Bmatrix} f_2x^{(2)} \\ f_2y^{(2)} \\ f_3x^{(2)} \\ f_3y^{(2)} \end{Bmatrix} = AE/L \begin{pmatrix} c_2^2 & -c_2s_2 & -c_2^2 & c_2s_2 \\ -c_2s_2 & s_2^2 & c_2s_2 & -s_2^2 \\ -c_2^2 & c_2s_2 & c_2^2 & -c_2s_2 \\ c_2s_2 & -s_2^2 & -c_2s_2 & s_2^2 \end{pmatrix} \begin{Bmatrix} d_2x^{(2)} \\ d_2y^{(2)} \\ d_3x^{(2)} \\ d_3y^{(2)} \end{Bmatrix} \quad (5)$$

Similarly to element 3

$$\begin{Bmatrix} f_1x^{(3)} \\ f_1y^{(3)} \\ f_3x^{(3)} \\ f_3y^{(3)} \end{Bmatrix} = AE/L \begin{pmatrix} c_3^2 & c_3s_3 & -c_3^2 & -c_3s_3 \\ c_3s_3 & s_3^2 & -c_3s_3 & -s_3^2 \\ -c_3^2 & -c_3s_3 & c_3^2 & c_3s_3 \\ -c_3s_3 & -s_3^2 & c_3s_3 & s_3^2 \end{pmatrix} \begin{Bmatrix} d_1x^{(3)} \\ d_1y^{(3)} \\ d_3x^{(3)} \\ d_3y^{(3)} \end{Bmatrix} \quad (6)$$

By connecting equation 1 to 5 following matrix relationship can be obtained.

$$\begin{Bmatrix} F_1x \\ F_1y \\ F_2x \\ F_2y \\ F_3x \\ F_3y \end{Bmatrix} = AE/L \begin{pmatrix} (c_1^2 + c_3^2) & (c_1s_1 + c_3s_3) & -c_1^2 & -c_1s_1 & -c_3^2 & -c_3s_3 \\ & (s_1^2 + s_3^2) & -c_1s_1 & -s_1^2 & -c_3s_3 & -s_3^2 \\ & & (c_1^2 + c_2^2) & c_1s_1 - c_2s_2 & -c_2^2 & c_2s_2 \\ & & & s_1^2 + s_2^2 & c_2s_2 & -s_2^2 \\ & & & & (c_1^2 + c_2^2) & (c_3s_3 - c_2s_2) \\ & & & & & (s_2^2 + s_3^2) \end{pmatrix} \begin{Bmatrix} D_1x \\ D_1y \\ D_2x \\ D_2y \\ D_3x \\ D_3y \end{Bmatrix}$$

Symmetry

This matrix like  $F = Kx$ ; where K is the stiffness matrix. Above stiffness matrix K is symmetric. Thus  $|K| = 0$ . Therefore matrix K is singular and inverse of K does not exist. From above equation, displacement function  $x$  can't be found when the elements are unconstrained. [4],[5],[6].

Therefore this kind of system is going to be analyzed by a computer based FEA package, program issues error messages saying stiffness matrix is singular.

If a constraints are defined on the system above matrix equation is decomposed, K matrix is no longer singular. For eg. If node 1 is constrained,  $D_1x=D_1y = 0$  above matrix equation changed as follows,

$$\begin{Bmatrix} F_2x \\ F_2y \\ F_3x \\ F_3y \end{Bmatrix} = AE/L \begin{pmatrix} -c_1^2 & -c_1s_1 & -c_3^2 & -c_3s_3 \\ -c_1s_1 & -s_1^2 & -c_3s_3 & -s_3^2 \\ (c_1^2 + c_2^2) & c_1s_1 - c_2s_2 & -c_2^2 & c_2s_2 \\ c_1s_1 - c_2s_2 & s_1^2 + s_2^2 & c_2s_2 & -s_2^2 \\ -c_2^2 & c_2s_2 & (c_1^2 + c_2^2) & (c_3s_3 - c_2s_2) \\ c_2s_2 & -s_2^2 & -s_2^2 & (s_2^2 + s_3^2) \end{pmatrix} \begin{Bmatrix} D_2x \\ D_2y \\ D_3x \\ D_3y \end{Bmatrix}$$

In above matrix  $|K| \neq 0$ , hence inverse of K exists. Therefore system can be analyzed by computer based FEA package after node 1 is constrained.

### 1.2.2 Find displacement field of no-constrain CST plate element

Consider the CST elements shown below. Its co-ordinates are  $i(x_i, y_i)$ ,  $j(x_j, y_j)$ , and  $m(x_m, y_m)$ .

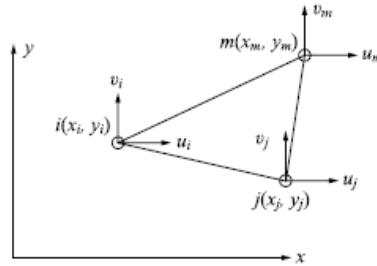

Figure 6: Displacement vectors of CST elements

Now element is moved in distance “a” and distance “b” in X and Y direction respectively when no constrains. Then new co-ordinates are  $i(x_i + a, y_i + b)$ ,  $j(x_j + a, y_j + b)$ , and  $m(x_m + a, y_m + b)$ . But forces of the system remain as F. new displacement field is  $d_1$ . According to the section 2.11, stiffness matrix is given as  $K = tA [B^T][D][B]$ . Then displacement of the corner points can be found by element equation(7).

$$F = Kd \quad \text{-----} \quad (7)$$

$$K = tA [B^T] [D] [B] \quad \text{-----} \quad (8)$$

$$B = [B_i \ B_j \ B_m] \quad \text{-----} \quad (9)$$

$$B_i = \begin{pmatrix} \beta_i & 0 \\ 0 & \gamma_i \\ \gamma_i & \beta_i \end{pmatrix} \quad B_j = \begin{pmatrix} \beta_j & 0 \\ 0 & \gamma_j \\ \gamma_j & \beta_j \end{pmatrix} \quad B_m = \begin{pmatrix} \beta_m & 0 \\ 0 & \gamma_m \\ \gamma_m & \beta_m \end{pmatrix} \quad \text{-----} \quad (10)$$

$$\left. \begin{array}{l} \beta_i = y_j - y_m, \quad \beta_j = y_m - y_i, \quad \beta_m = y_i - y_j, \\ \gamma_i = x_m - x_j, \quad \gamma_j = x_i - x_m, \quad \gamma_m = x_j - x_i, \end{array} \right\} \quad \text{-----} \quad (11)$$

After element is moved to new position matrix B is converted to  $B^*$ . By equation (10)  $B^*$  can be calculated as follows.

$$\beta_i = y_j + b - (y_m + b) = y_j - y_m, \quad \beta_j = y_m + b - (y_i + b) = y_m - y_i, \quad \beta_m = y_i + b - (y_j + b) = y_i - y_j, \\ \gamma_i = x_m - x_j, \quad \gamma_j = x_i - x_m, \quad \gamma_m = x_j - x_i$$

According to equation (9),(10)  $B^* = B$ . Hence by equation (8) stiffness matrix remains same. Then by equation (7) corner point displacements or matrix  $d$  are remained same.

By section 2.11

$$\left. \begin{array}{l} \varepsilon = [B](d) \\ \sigma = D[B](d) \end{array} \right\} \quad \text{-----} \quad (12)$$

Since matrix B and  $d$  are remained unchanged, strain field  $\varepsilon$  and stress field  $\sigma$  remained unchanged after element moved without constrained. Thus,

$$\alpha_i = (x_j + a)(y_m + b) - (y_j + b)(x_m + a), \quad \alpha_j = (y_j + b)(x_m + a) - (x_i + a)(y_m + b) \\ , \quad \alpha_m = (x_i + a)(y_j + b) - (y_i + b)(x_j + a),$$

$\alpha_i, \alpha_j$  and  $\alpha_m$  are changed when the element moves a and b distanced in x and y directions respectively. General displacement fields are;

$$\begin{aligned} \{u(x,y)\} &= 1/2A \{(\alpha_i + \beta_i x + \gamma_i y)u_i + (\alpha_j + \beta_j x + \gamma_j y)u_j + (\alpha_m + \beta_m x + \gamma_m y)u_m\} \\ \{v(x,y)\} &= 1/2A \{(\alpha_i + \beta_i x + \gamma_i y)v_i + (\alpha_j + \beta_j x + \gamma_j y)v_j + (\alpha_m + \beta_m x + \gamma_m y)v_m\} \end{aligned} \quad (13)$$

According to equation (13), general displacement field change when the element is moved to new position without constrains. But corner point's displacements, strains, and stress filed remain unchanged. In other word, when the element becomes unconstrained, displacement function has infinite values and stress and strain field remained unchanged.

For plane stress element [4]  $D = \left(\frac{E}{1-\nu^2}\right) \begin{bmatrix} 1 & \nu & 0 \\ \nu & 1 & 0 \\ 0 & 0 & \nu' \end{bmatrix}$  ;  $\nu'=(1-\nu)/2$

By equation 8;

$$k = tA \begin{bmatrix} \beta_i & 0 & \beta_j & 0 & \beta_m & 0 \\ 0 & \gamma_i & 0 & \gamma_i & 0 & \gamma_i \\ \gamma_i & \beta_i & \gamma_j & \beta_j & \gamma_m & \beta_m \end{bmatrix}^T \left(\frac{E}{1-\nu^2}\right) \begin{bmatrix} 1 & \nu & 0 \\ \nu & 1 & 0 \\ 0 & 0 & \nu' \end{bmatrix} \begin{bmatrix} \beta_i & 0 & \beta_j & 0 & \beta_m & 0 \\ 0 & \gamma_i & 0 & \gamma_i & 0 & \gamma_i \\ \gamma_i & \beta_i & \gamma_j & \beta_j & \gamma_m & \beta_m \end{bmatrix}$$

$$k = tA \left(\frac{E}{1-\nu^2}\right) \begin{bmatrix} \beta_i^2 + \nu' \gamma_i^2 & \beta_i \gamma_i \nu + \nu' \gamma_i \beta_i & \beta_i \beta_j + \nu' \gamma_i \gamma_j & \beta_i \gamma_j \nu + \nu' \gamma_i \beta_j & \beta_i \beta_m + \nu' \gamma_i \gamma_m & \beta_i \gamma_m \nu + \nu' \gamma_i \beta_m \\ \gamma_i^2 + \nu' \beta_i^2 & \beta_j \gamma_i \nu + \nu' \gamma_j \beta_i & \gamma_i \gamma_j + \nu' \beta_i \beta_j & \beta_m \gamma_i \nu + \nu' \beta_i \gamma_m & \gamma_i \gamma_m + \nu' \beta_i \beta_m & \gamma_i \gamma_m + \nu' \beta_i \beta_m \\ \beta_j^2 + \nu' \gamma_j^2 & \beta_j \gamma_j \nu + \nu' \beta_j \gamma_j & \beta_i \beta_m + \nu' \gamma_j \gamma_m & \beta_j \gamma_m \nu + \nu' \gamma_j \beta_m & \beta_j \gamma_m \nu + \nu' \gamma_j \beta_m & \beta_j \gamma_m \nu + \nu' \gamma_j \beta_m \\ \gamma_j^2 + \nu' \beta_j^2 & \beta_m \gamma_j \nu + \nu' \beta_j \gamma_m & \gamma_j \gamma_m + \nu' \beta_j \beta_m & \beta_m \gamma_j \nu + \nu' \beta_j \gamma_m & \gamma_j \gamma_m + \nu' \beta_j \beta_m & \beta_m \gamma_j \nu + \nu' \beta_j \gamma_m \\ \beta_m^2 + \nu' \gamma_m^2 & \beta_m \gamma_m \nu + \nu' \gamma_m \beta_m & \beta_m \gamma_m \nu + \nu' \gamma_m \beta_m & \beta_m \gamma_m \nu + \nu' \gamma_m \beta_m & \beta_m \gamma_m \nu + \nu' \gamma_m \beta_m & \beta_m \gamma_m \nu + \nu' \gamma_m \beta_m \\ \gamma_m^2 + \nu' \beta_m^2 & \gamma_m^2 + \nu' \beta_m^2 & \gamma_m^2 + \nu' \beta_m^2 & \gamma_m^2 + \nu' \beta_m^2 & \gamma_m^2 + \nu' \beta_m^2 & \gamma_m^2 + \nu' \beta_m^2 \end{bmatrix}$$

Symmetric

Above stiffness matrix K is symmetric and  $|K| = 0$ . Therefore matrix K is singular and inverse of K does not exist. By equation 7, displacement function  $\{d\}$  can't be found when the element is unconstrained. [6].

Therefore this kind of system can't be analyzed by a computer based FEA package since displacement function is ambiguous and stiffness matrix is singular .

### 1.2.3. Analysis of a simple un-constraints body by computer base FEA package

After theoretical explanation about un-constraints body in section 1.2.1 and 1.2.2, now it is considered to analyze a un-constraints body by FEA packages. As following figure shows, beam of which total length is 1000mm. Half of its length has 20mm diameter circular cross section and rest has 25mm diameter circular cross section. This beam is subjected to 1000N forces at two ends as follows. Since beam is equilibrium under only subjected forces, beam can be considered as an un-constraint body.

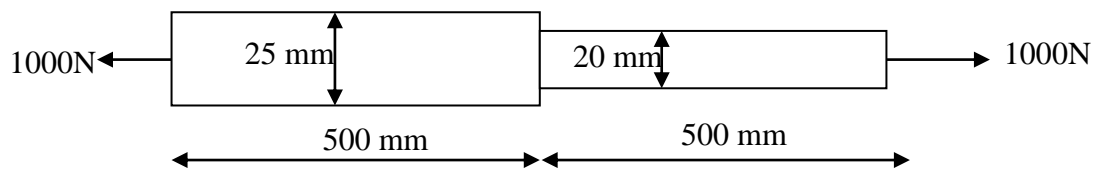

Figure 7: Schematic diagram of un-constrained beam

When above un-constraint beam is analyzed by Abaqus, ANSYS, Nastran, Femap, Strand7 and Solidworks Simulia, it gave following error messages as following figures.

```
ELAPSED USER TIME (SEC)      = 0.0000
ELAPSED SYSTEM TIME (SEC)    = 0.10000
ELAPSED TOTAL CPU TIME (SEC) = 0.10000
ELAPSED WALLCLOCK TIME (SEC) = 0

***WARNING: SOLVER PROBLEM: NUMERICAL SINGULARITY WHEN PROCESSING NODE
PART-1-1.27 D.O.F. 1 RATIO = 1.83057E+15.

CONVERGENCE CHECKS FOR EQUILIBRIUM ITERATION 1

AVERAGE FORCE          33.8      TIME AVG. FORCE          33.8
LARGEST RESIDUAL FORCE -1.407E-12 AT NODE      50 DOF 1
INSTANCE: PART-1-1
LARGEST INCREMENT OF DISP. 2.290E-04 AT NODE      3 DOF 1
INSTANCE: PART-1-1
LARGEST CORRECTION TO DISP. 2.290E-04 AT NODE      3 DOF 1
```

Figure 8: Error message in Abaqus output

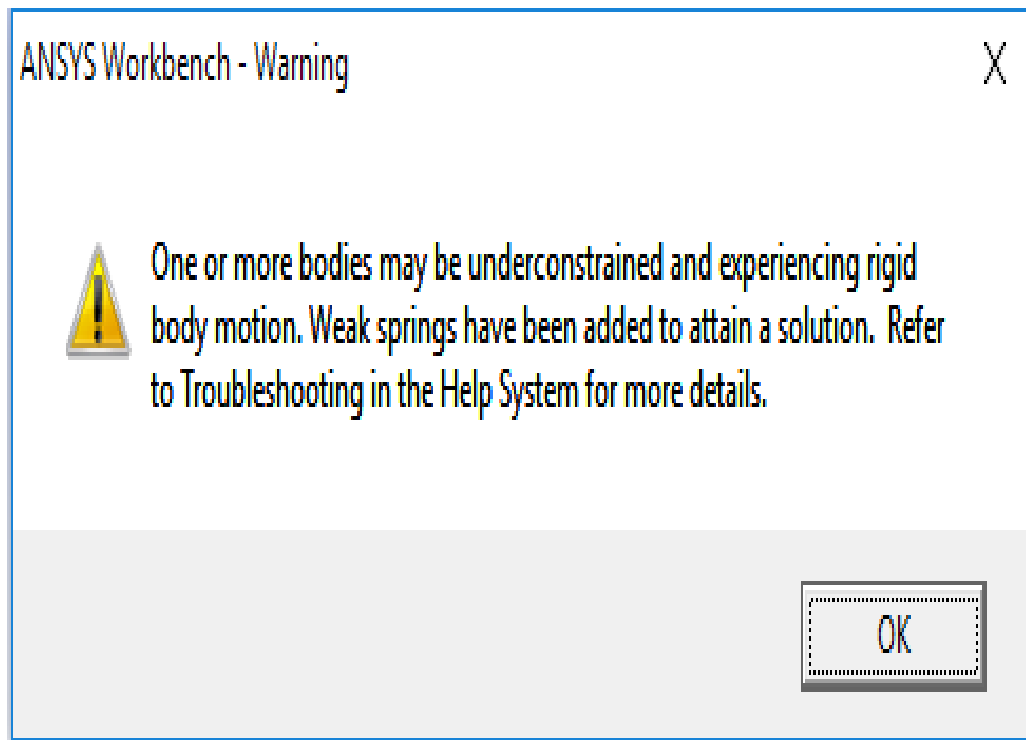

Figure 9: Error message in ANSYS output

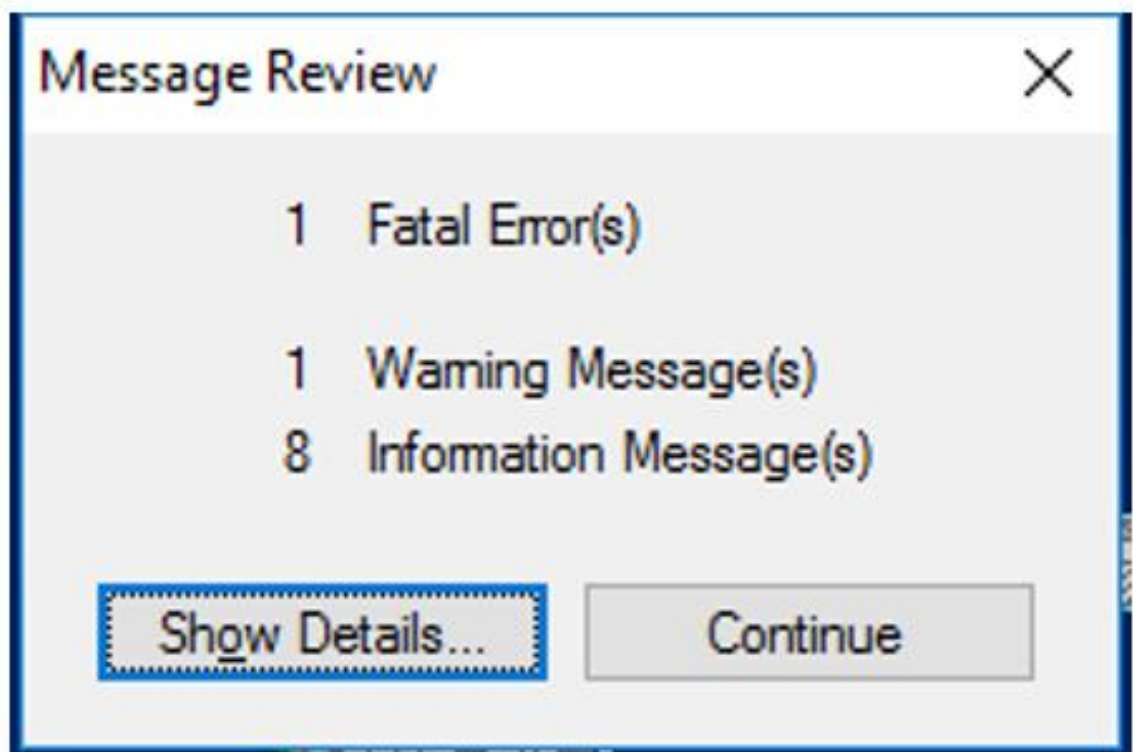

Figure 10: Error message of Nastran solver

```

** USER WARNING MESSAGE 4698 (DCMPD)
STATISTICS FOR DECOMPOSITION OF MATRIX KLL
THE FOLLOWING DEGREES OF FREEDOM HAVE FACTOR DIAGONAL RATIOS GREATER THAN
1.00000E+07 OR HAVE NEGATIVE TERMS ON THE FACTOR DIAGONAL.
USER INFORMATION:
THIS MESSAGE MAY BE IGNORED IF NO GRID POINT IDS OR HIGH RATIO MESSAGES APPEAR IN THE TABLE ON THE NEXT PAGE.
User information:
During decomposition, the degrees of freedom listed have pivot
ratios that are that are greater than maxratio or are negative.
Verify that the degrees of freedom are not part of a mechanism
and that elements do not have excessive stiffness. In superelement
analysis this condition causes run termination. PARAM,BAILOUT may
be used to continue the run. See the NX NASTRAN Numerical Methods
User's Guide.
GRID POINT ID      DEGREE OF FREEDOM  MATRIX/FACTOR DIAGONAL RATIO    MATRIX DIAGONAL
5058                T2                 -2.01954E+14                    2.02779E+05
5058                T3                 8.95301E+13                     1.79154E+05
5249                T3                 8.81152E+11                     1.78668E+05
^^^ USER FATAL MESSAGE 9137 (SEKRRS)

```

Figure 11: Error message of FEmap solver

```

*ERROR[ 4]:Global stiffness matrix is singular.

*Solution terminated on 07/07/2015 at 12:33:03
*Solution time: 0 Seconds

*SUMMARY OF MESSAGES
*Number of Notes      : 0
*Number of Warnings   : 1
*Number of Errors     : 1

```

Figure 12:error message in Strand7 solver



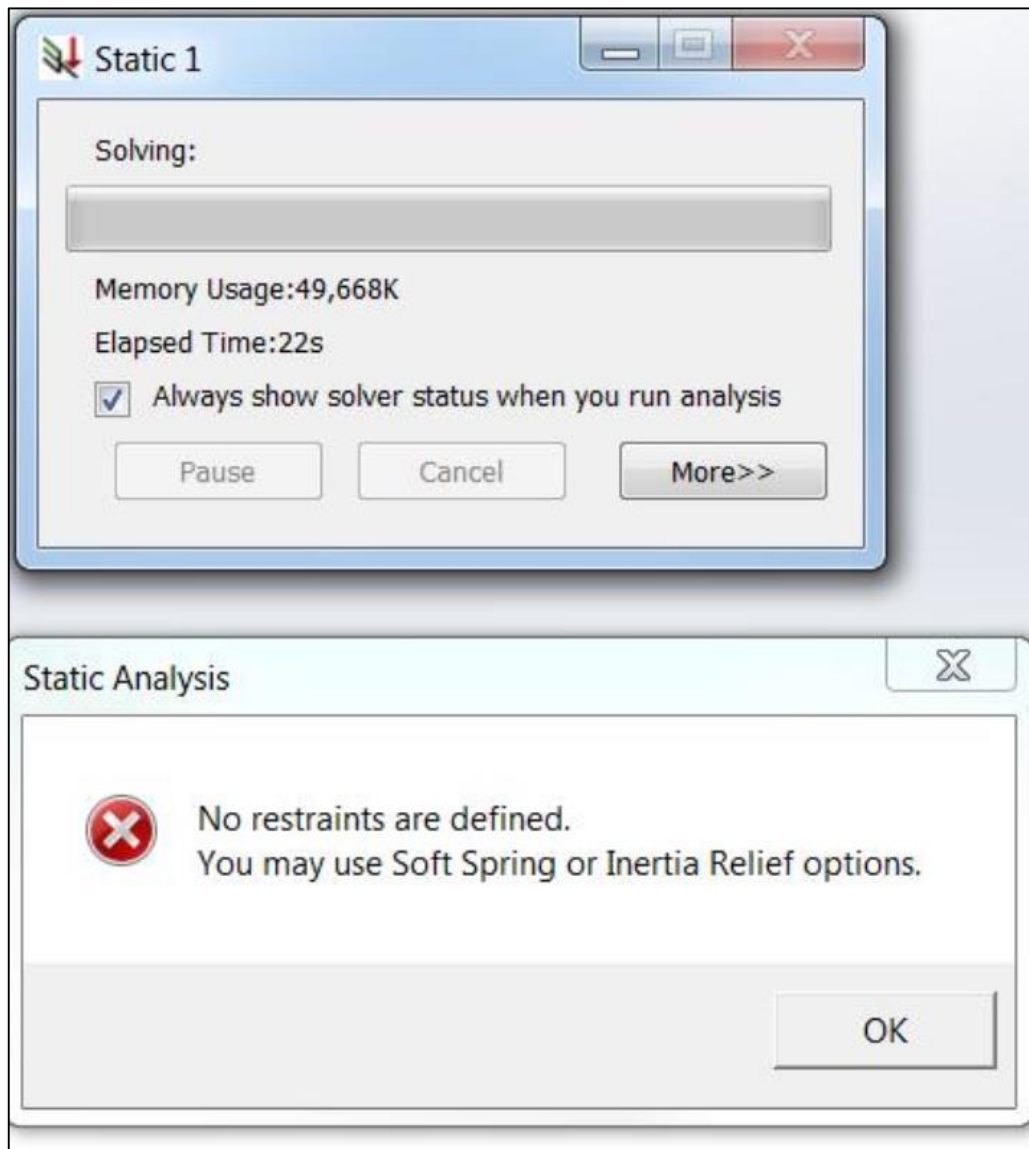

Figure 13: Error message in SolidWorks simulation

According to message given by Abaqus analysis, model is unstable and results are not valid [4],[6]. ANSYS package directly gives an indication that model is unconstrained and model has a rigid body motion. Hence results can't be obtained. Nastran solver terminates the simulation giving a fatal error as shown by the figure 10. Therefore solution is not reachable for un-constraint body. According to the Femap solver, stiffness matrix is singular due to diagonal elements are negative. Therefore analysis can't be proceeded. According to Strand7 solver it gives a message as global stiffness matrix is singular. Hence Strand7 is unable to find displacement of un-constraint beam [4],[6]. When the above beam is analyzed by

SolidWorks simulation, at the very beginning of the simulation, analysis is paused with error message saying no constraints are defined.

Then, this simple beam can be analyzed by defining constraints to the system. But these constraints should not interfere to system. since this is a very simple beam with only axial forces, beam can be given fixed boundary condition to any position and it will not create external forces and moment to the system. But when the system become and more complex, defining these kind of constraints are not a simple task and those kinds of approaches are discussed in the next chapters of this research work.

## **1.2 Objective**

The objective of this study is to introduce a few constraints to a system which has no adequate constraints to analyse the system by computer based FEA package, in such a way that these newly added constraints should not generate any forces or moment to the structure. After these new constraints are introduced, system is at fixed state with reference to a reference frame. This newly added constraints give a method to determine displacements unambiguously without changing original forces, moment, stress-strain systems in the structure. Hence these constraints are called virtual constraints and it provides necessary boundary conditions to solve the displacement field.

Further these constraints are used to analyze dynamic system by a static analysis software where reverse inertia forces are applied to all the nodes of the system, then system becomes equilibrium.

## 2. LITERATURE REVIEW

### 2.1 Studies done on virtual supports

A rotating body or systems can be in equilibrium, if its rate of rotation is constant and remains unchanged by the forces acting on it. A rigid body is in static equilibrium when it is at rest in our selected frame of reference.

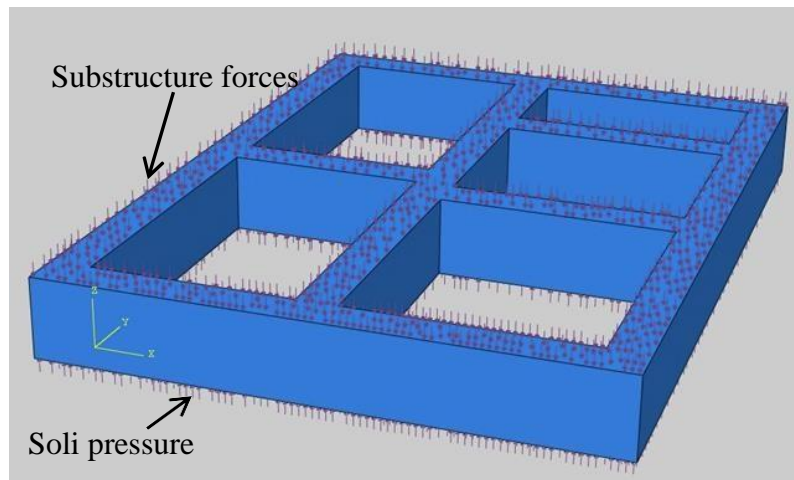

Figure 14: Rigid foundation with no supports

As an example, a rigid foundation (see Figure 14) which is equilibrium under superstructure forces and soil pressure distribution [7][35]. This foundation is a rigid foundation because ground support is replacing with soil pressure loading and the structure does not have supports. In these types of conditions, computer FEM packages gives error message “This structure is unstable, since there are no restraints”. To address this issue and solve the problem by using existing computer packages, it can be introduced some specific supports or supporting conditions to the structure, that are in equilibrium [7][36]. After new supports were introduced to the structure, it did not change the internal forces in the original structure. These specific supports were adequate to convert structure to stable for computer packages and then it could precede the analysis. After the computer packages completed the analysis with newly introduced supports, it can be shown that reaction forces of all those newly introduced supports are zero.

When the virtual supports or displacements are introduced to a structure, which are already in equilibrium state and then systems can be solved [7][37][38]. Then virtual constraints can be used to analysis dynamic or static systems in equilibrium state by available FEM commercial software packages.

Sungwon Lee, Chaeho Lim and Siyoung Kwak have published a paper on “as efficient method for thermal stress analysis considering influence of displacement boundary condition (DBS)” [8], where they have described the influence of proper boundary condition for thermal simulation and proposed a method to perform thermal stress analysis without boundary conditions when in it was delicate to decide correct boundary conditions for thermal stress analysis.

According to their study, there are no extract mechanical constraints in thermal stress analysis when perform simulation like heat treatment and cast process [8]. In casting process, heated melting metal is poured into mold and melting metal is solidified. Then thermal stress and deformation can be calculated by computational simulation. If improper boundary condition is assigned, rigid body motion and stress concentration can be occurred. But by this paper, it was proposed a technique to obtain unique thermal stress by solving algebraic matrix equation without any boundary condition. This technique can be shown by following flow chart.

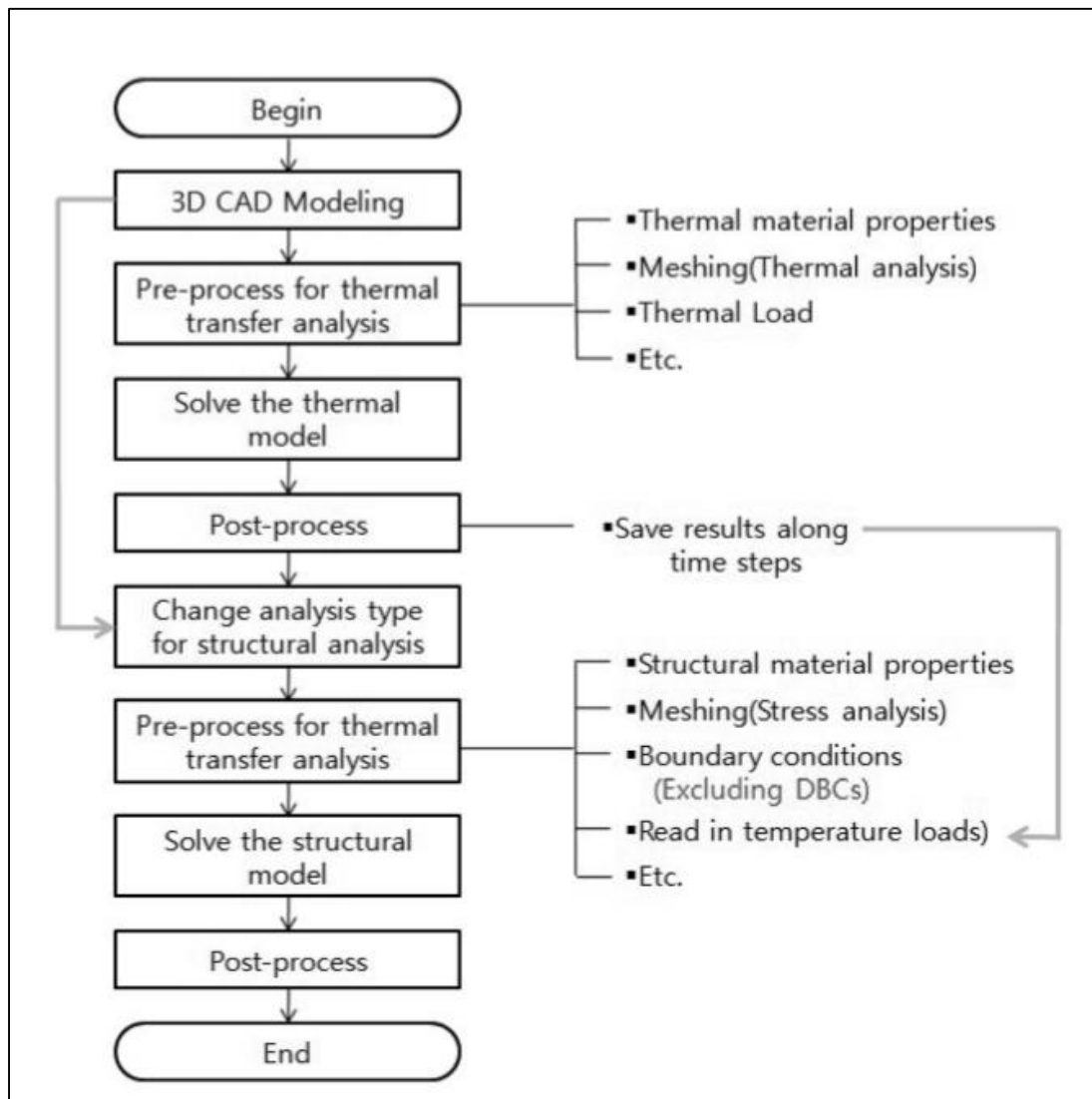

Figure 15: Flow chart followed to get unique thermal stress without DBC s

According to flow chart, thermal analysis is performed only considering thermal loads at the first stage and the second stage structural analysis is done. But at this stage, load are considered as the thermal load generated at first simulation. With this method, it was shown that thermal stress analysis could be done not only avoid applying DBs but also prevent stress concentration.

Serdobintsev Yu.P. and Ivanyuk A.K. published a paper on “Analyzing the Stress-Strain State of Object Bodies Subjected to Hydrostatic Pressure using Modern CAD Systems” [9] in 2016. Under this paper it was developed a computer aided monitoring system for bodies which subjected to hydrostatic pressure, in order to

know the area where maximum shear stress exists. Stress concentration was calculated by Finite Element aided by CAD system. According to this paper an object was considered which has been subjected to hydrostatic pressure as following figures.

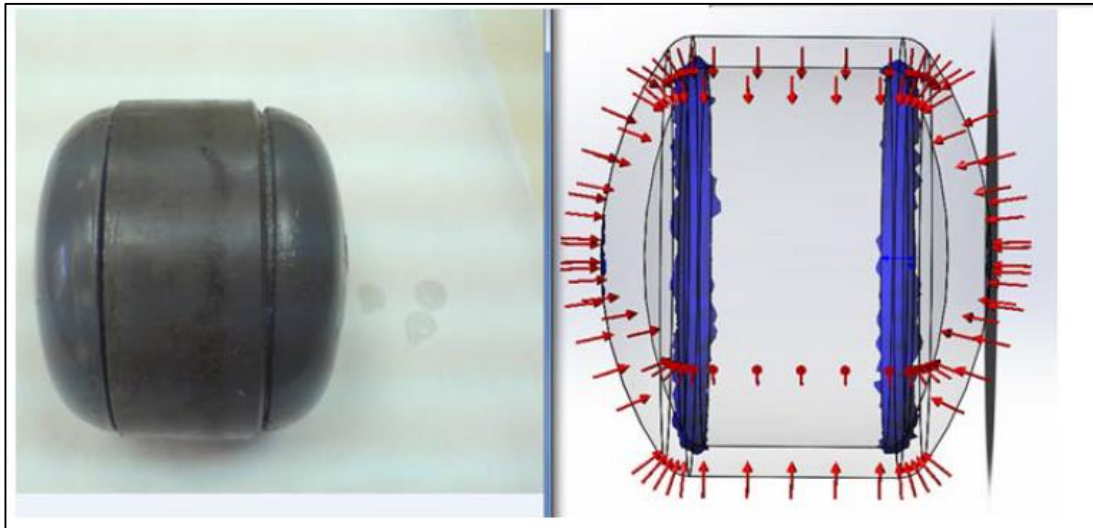

Figure 16: Hydrostatic pressure on the object

When the constraints were given to this model, it could constrain vertical direction, since at the real situation object was on the ground. However, no constraints were defined in to the horizontal direction. Hence FE analysis could not be proceeded without another constraint. Then mid plane of the model was given constrains in such a way that horizontal movement and rotation around vertical directions were fixed. After given, these constraints simulation result was given as figure 17.

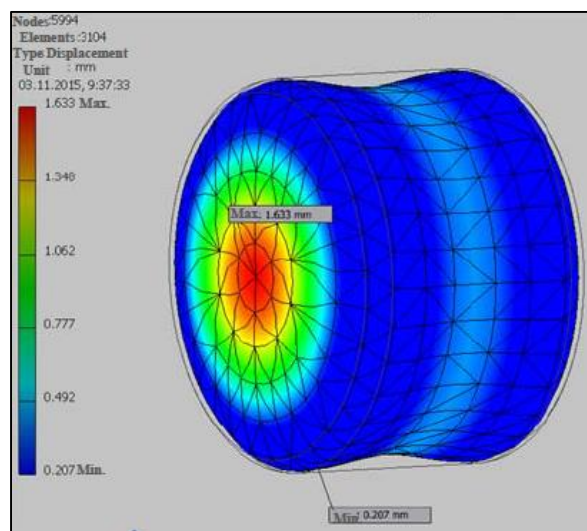

Figure 17: FE simulation result

S.Y. Kwak, C.H. Lim and J.H. Nam published a paper on “Effect of displacement boundary conditions on thermal deformation in thermal stress problem” [10] in May 2013. As the paper describes, when structures are analyzed by computer packages or FEA, it is solved algebraic equations. If proper boundary condition has not been defined, global stiffness matrix is singular due to zero determinant of the matrix. In real situation, structure is free to float in space until proper boundary conditions are defined.

Unlike mechanical system, when dealing with thermal stress analysis such as heat treatment and casting process, there are no exact mechanical constraints. But in the general thermal stress analysis, it is arbitrarily applied displacement boundary conditions and stress concentration due to these arbitrarily constraints is ignored after analysis.

But in this paper, it was introduced a method to perform thermal stress analysis without DBC to solve a system of algebraic equations step. After, rigid body motion generated during the solving was removed in the post process step.

The procedure followed to remove rigid body motion is given below with figure 18.

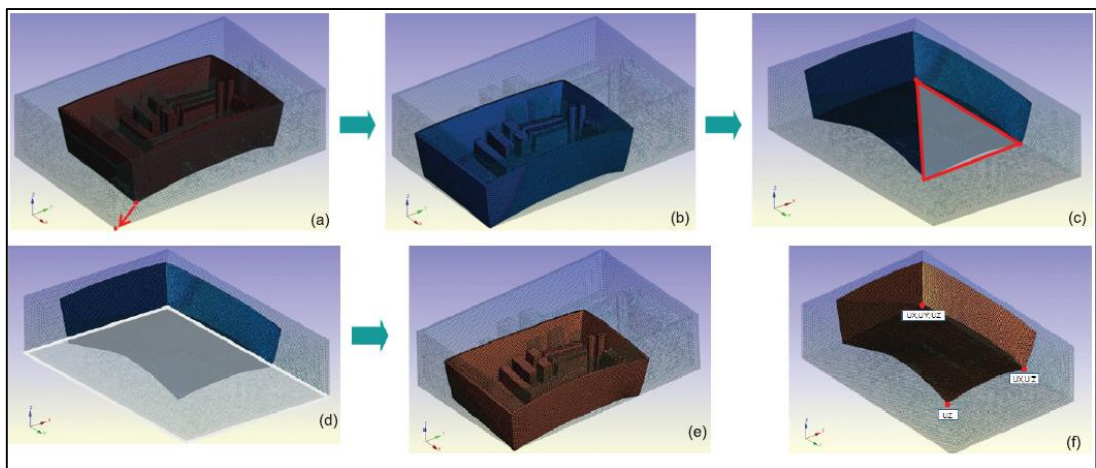

Figure 18: procedure to remove rigid body motion from deformation result solved without DBCs

1. select a one node to fix.( Figure 18(a))
2. Translate all displacements to fixed node coordinates.( Figure 18(b))
3. Define source plane by selecting three nodes. (Figure 18 ©)



4. Select target plane where the source plane can be placed. (Figure 18(d))
5. Rotate target plane where the source plane can be placed. (Figure 18(e))

## **2.2 Finite Element Method**

This is a numerical method used to get solution of engineering problems like automotive, aircraft, building and bridge structures, and physics like heat flux, fluid flow, magnetic field, seepage and other flow problems. Generally analytical solution given by any mathematical equation yields the value of unknown quantity at any location of a body. When the geometry becomes complicated with complex geometry features and involve loadings material properties, analytical solutions are impossible. The analytical method basically solves differential equations (partial or ordinary) which are not always possible to solve in complex situation. Hence finite element method is used as a numerical method which formulates simultaneous algebraic equation rather than differential equations. This method modeling a body by dividing it into equivalent systems of smaller bodies or finite elements connect with another element by common points called nodes and finally called as called discretization. In the Finite Element Method equations are formulated for each element and combine them to get a solution for whole body[11].

## **2.3 Brief History**

Originally concept of finite element method came from advances in aircraft structural analysis. In 1942, Henikoff presented a solution of elasticity problems by method called frame work method. In 1943, Courants submitted a paper to torsion problem by piecewise polynomial interpolation over triangular subdomain. Turner,er al presented a paper in1956 and derived stiffness matrices for trust, beam and other elements.

In the early 1960, a method had used for approximate solution of problems in stress analysis, fluid flow, heat transfer and other areas. Argyris introduce energy theorem and matrix methods in 1955 and this was a foundation for development in Finite element studies. By 1960 and early 1970,finite element analysis was applied to nonlinear and larger deformations problems,[11].

## **2.4 Computers for FEA**

Finite element method involve large number of algebraic equations and matrix methods for complicated systems. Therefore initially, this method was not readily adaptable for solving such systems since computers were not used. But invention of computer solve such large systems within a few seconds.

First computer was built up in 1904 based on vacuum tube technology, but gradually changed to transistor by 1950. By 1959, computers were developed with integrated circuit based technology which enhance the processing speed greatly result in solve larger finite element problems with increased degree of freedom [12],[13].

Modern development of computer result in writing general purpose and special purpose programs to work with various types of complex systems. Today finite element program can be solved in single processor machine or on a cluster of computer nodes. High speed processors with powerful memories can solve problems with over a million unknowns.

When the finite element program is solved by a computer, user should feed input as position of the element nodal coordinates, the manner in which elements are connected, material data ,loading and boundary conditions or constrains and the kind of analysis to be performed [14]. The computer then uses this information to write equations which necessary to solve.

## **2.5 Finite Element and computers**

In the market there are two types of computer packages to solve problems by finite element method. General purpose program has been developed to cover large area of FEA analysis. These general purpose program has an element library which can be used to model almost every structures. When working with general purpose software, user should not have special knowledge on computer software and user has chance to work with large range of analysis types. initial cost for the general

purpose software is very high and it is less efficient than special purpose program because software does several checks [15].

But some packages are designed by analysts with built-in optimization procedure to solved small specific problem and these packages are called special purpose programs. special purpose software are comparatively cheap and can run in a small computer. Problems are solved in very efficiently by special purpose software. Generally special purpose programs are difficult to modify for other analysis [16].

Today there are vendors who developed number of Finite Element Packages to get solution of structural and solid mechanics. some of them are listed below.

1. Algor
2. Abaqus
3. ANSYS
4. COSMOS/M
5. Femap
6. MARC
7. MSC/NASTRAN
8. NISA
9. Pro/MECHANICA
10. SAP2000
11. Strand7

Each finite element program package consists of three parts [4]. They are

1. Programs for preparation and control of the initial data,
2. Programs for solution of the finite element problem,
3. Programs for processing of the results.

These FEA packages have different element types such as membrane, solid, and axisymmetric that has linear, quadratic and cubic approximation. Programs can run as static or dynamic analysis. Several loading types such as concentrated load, distributed load ,thermal load displacements are found of these packages [14].

In this research work, Abaqus was used as the main FE analysis package. Hence it is given a short description on Abaqus on next chapter.

## **2.6 Abaqus as general purpose software**

Abaqus standard, Abaqus explicit and Abaqus CFD are the major three products of abaqus. The Abaqus/Aqua option is available with Abaqus/Standard and Abaqus/Explicit. The Abaqus/Design and Abaqus/AMS options are available with Abaqus/Standard. Abaqus/CAE is shorten form for “complete Abaqus environment” which can perform preprocessing, interactively submitting and monitoring Abaqus jobs, and evaluating results. Abaqus viewer is a subset which is used only to visualize the results. Addition to these abaqus products, it can create interface for mold flow and interface for MSC.ADAMS which are interfaces to mold flow and ADAMS/Flex respectively [17].

## **2.7 Main steps of Abaqus analysis**

Abaqus has major steps to analysis a model. They are discretizing the geometry, assign the element, material data, loading and constrains, analysis type and output request.

### **2.7.1 Discretize the model**

Physical structure is discretized into finite number of elements and nodes. These elements are with different shapes and connected to one another by shared nodes. The co-ordinates of the nodes and the connectivity of the elements comprise model geometry. The synergetic collection of elements and nodes are called mesh. Mesh is approximately equal to actual physical structure.

FEA results depends on element type, shape location and mesh density. Higher the mesh density, higher the accuracy. But higher the mesh density, higher the computational cost. When the mesh density is increased, results are converged to unique solution.

Basically discretization has two types. They are linear and quadratic. When the linear discretization is used for 2D triangular elements, displacement function of

nodes behave as  $a_1+a_2x+a_3y$ . when the quadratic discretization is used for 2D triangular elements, displacement function of nodes behave as  $a_1+a_2x+a_3y+a_4x^2+a_5y^2+a_6xy$ . Coefficients  $a_1$  to  $a_6$  are constants.

### **2.7.2 Element section properties**

Abaqus provide a large range of elements which include one dimensional (1D), two dimensional (2D) and three dimensional (3D). Beam elements, truss elements, shell elements, plane stress elements, plane strain elements, membrane elements, brick elements, rigid elements, connector elements, and tetrahedron elements are a few examples to elements available in the Abaqus [18].

### **2.7.3 Material data**

Abaqus has facilities to input general properties, mechanical properties, thermal properties and electrical properties. Material properties must be given to all the elements of the model. The validity of the Abaqus results depend on the quality of the material model used in Abaqus.

### **2.7.4 Loads module in Abaqus**

Loads result in distortion of the model. Distortion creates stress on the model. Abaqus can define several loading types or forces such as point forces, pressure forces, rotational body forces, Coriolis forces, inertia relief forces, surface traction forces, pipe pressure force, body force, line force, and shell edge force [17][18].

#### **2.7.4.1 Define a pressure load**

A pressure load is defined on a surface on the model. Pressure load is given as value per unit area. Pressure can be given as positive or negative value on the selected surface.

#### **2.7.4.2 Define rotational body forces**

Abaqus has facilities to define rotational body forces either from rotation or acceleration of a body, in order to define rotational body forces. Then angular velocity or rotary acceleration should be provided to model as input data. It is essential to define axis of rotation of the angular velocity or acceleration.

#### **2.7.4.3 Define Coriolis forces**

Abaqus has capability to model Coriolis forces. As input data, product of density and angular velocity needs to be given to the model. Axis of rotation should be indicated before the proceeding the analysis.

#### **2.7.4.4 Define concentrated forces**

Concentrated forces are defined on the nodes or vertices of the model. Force can be defined on X,Y or Z direction with respect to global axis or local axis system.

#### **2.7.4.5 Define inertia relief load**

Facility of inertia relief load is a very powerful tool found in Abaqus, which is applied to balance the externally applied load on a free or partially free body. One example of where inertia relief load applied is that when a rocket lift off it has an acceleration and inertia relief load can balance the externally applied load. Then model can be analyzed as a static simulation.

#### **2.7.4.6 Define a surface traction force**

Surface traction forces are used to define general traction on a surface in a model.

#### **2.7.4.7 Define pipe pressure load**

Abaqus define internal or external pipe pressure loads in elbows and pipes.

#### **2.7.4.8 Define body forces**

Body force is defined as the loading per unit volume. In three dimensional analyses body force is can be defined in global X, Y and Z direction. But in two dimensional cases body forces are defined only in global X and Y direction only.

#### **2.7.4.9 Define gravity load**

All the objects in the space are subjected with gravitational forces those can be calculated by multiplying mass by acceleration. In FEA modeling, this is done by input acceleration in X,Y and Z directions to the model. Then system can calculate the gravity load in X, Y and Z directions.

#### **2.7.4.10 Define a line load**

Line load is defined as loading per unit length in a beam.

#### **2.7.4.11 Define generalize plane strain load**

Abaqus creates generalized plane strain load to define an axial load which applied to the reference point of a region created with plane strain elements.

#### **2.7.4.12 Define a moment**

A rotation of a vertex or a node is defined by moment in Abaqus. This moment can be defined around X,Y and Z axis of global coordinate system.

#### **2.7.4.13 Define a shell edge load**

General shear, normal or transverse traction or moment along shell edge can be defined in Abaqus.

### **2.8 Define boundary condition in Abaqus**

Abaqus can define boundary condition as symmetry/antisymmetric, encastre, pinned, velocity and acceleration boundary condition. Restrain applicable to each boundary condition definitions are as follows [19].

#### **2.8.1 XSYMM Symmetry about a plane $X = \text{constant}$ ( $U1 = UR2 = UR3 = 0$ )**

Model is symmetric about plane X and boundary nodes can't move in X direction. Boundary nodes can't rotate around Y and Z axis.

#### **2.8.2 YSYMM Symmetry about a plane $Y = \text{constant}$ ( $U2 = UR1 = UR3 = 0$ )**

Model is symmetric about plane Y and boundary nodes can't move in Y direction. Boundary nodes can't rotate around X and Z axis

#### **2.8.3 ZSYMM Symmetry about a plane $Z = \text{constant}$ ( $U3 = UR1 = UR2 = 0$ )**

Model is symmetric about plane Z and boundary nodes can't move in Y direction. Boundary nodes can't rotate around X and Y axis

#### **2.8.4 XASYMM Anti-symmetry about a plane with $X = \text{constant}$ ( $U2 = U3 = UR1 = 0$ )**

Model is anti-symmetric around X Plane. Boundary nodes can't move in Y and Z direction. Rotation around X axis also restricted.

### **2.8.5 YASYMM Anti-symmetry about a plane with $Y = \text{constant}$ ( $U1 = U3 = UR2 = 0$ )**

Model is anti-symmetric around Y Plane. Boundary nodes can't move in X and Z direction. Rotation around Y axis also restricted.

### **2.8.6 ZASYMM Anti-symmetry about a plane with $Z = \text{constant}$ ( $U1 = U2 = UR3 = 0$ )**

Model is anti-symmetric around Z Plane. Boundary nodes can't move in X and Y direction. Rotation around Z axis also restricted.

### **2.8.7 PINNED Pinned ( $U1 = U2 = U3 = 0$ )**

Boundary nodes are allowed only to rotate. This boundary condition transfer only forces.

### **2.8.8 ENCASTRE Fully built-in ( $U1 = U2 = U3 = UR1 = UR2 = UR3 = 0$ )**

All six degree of freedom is restrained by encastre boundary condition. These kinds of boundary conditions can transfer forces and moments.

### **2.8.9 Defining velocity/angular velocity boundary condition**

Abaqus can define a velocity/angular velocity boundary condition to introduce a velocity for the selected degrees of freedom of the selected nodes.

### **2.8.10 Defining acceleration/angular acceleration boundary condition**

Abaqus can define an acceleration/angular acceleration boundary condition to prescribe acceleration for the selected degrees of freedom of the selected region's nodes.

## **2.9 Depth in to Finite element analysis**

Initially FEA was developed for stress analysis, but gradually evaluated to analyze thermal analysis, fluid flow, piezoelectric analysis and many others. Target of analysis is to determine the distribution of field variables like the displacement in stress analysis, the temperature or heat flux in thermal simulation, the electrical charge in electrical analysis, and so on. In FEA analysis, approximate solution of distribution of field variables is obtained by numerical method, when it is very difficult to apply analytical method to complex geometries. Above mentioned



numerical technique is applied by dividing the problem domain in to several simple elements (discretize) and known physical laws are applied to simple elements.

Then, continuous function of an unknown field variables (like displacement, temperature) is approximated using piecewise linear functions in the elements or sub-domains. After following proper principles to elements, a set of linear algebraic simultaneous equations are formed to solve required field variables [20].

when FEA is used for structural mechanism problem, two different approaches are associated. One approach is force or flexibility method and other approach is called displacement or stiffness method.

In the force or flexibility method is based on the classic elasticity. Force equilibrium is taken for calculating the displacement.

The displacement method foundation of current modern FEA method, based on the stiffness matrix which is derived from a kinematically admissible displacement [5].

After discretized the domain, several approaches are applied to get discrete simultaneous equations. Traditional FEA used energy approaches such as minimum potential theorem and virtual works theorem to get simultaneous equations. Minimum potential energy (MPE) principal is applied to material behaving in a linear elastic manner. But principal of virtual works is applied to material both behave in linear and nonlinear manner. Both two methods are used for solid and structural analysis. Another approach is weighted residual method and it is often used to fluid flow analysis[20] .

In FEA process, there are basic seven steps. They are

2.9.1 |Discretization and element selection

2.9.2 Selection a displacement function

2.9.3 Define the strain/displacement and stress/strain relationship

2.9.4 Derive element stiffness matrix and equations

2.9.5 Assembly the element equations to obtain the global or total equations and introduce boundary conditions

2.9.6 Solve for the unknown degree of freedom or generalized displacement

2.9.7 solve for the element stress and strain

2.9.8 Interpret the results

### 2.9.1. Discretization and element selection

First main domain is divided in to small known or simple finite particles known as elements. These elements associate with nodes, and element type should be selected in such a way that FEA model created by collection of all elements as model is very close to virgin geometry. When the element size becomes small, results become usable and wen the element size is increased, simulation results in low computational cost. In computer based FEA packages, this process is known as meshing and mesh generation is an automatic function in FEA packages [21].

According to topology and properties, there are several element types used in FEA. Elements that are commonly employed in applications are given below.

Basic line elements include truss and beam elements. Bar elements have constant cross sectional area throughout the element's length evenif cross sectional area can vary within the element in actual scenario. Both bar (truss) and beam elements are represented by line. Trust and beam elements are used to model trusses and frame structures. The simplest line element called linear elements consist of two nodes at each ends, and higher-order elements called quadratic and cubic type have three nodes as additional one node is located at the center of the line element.

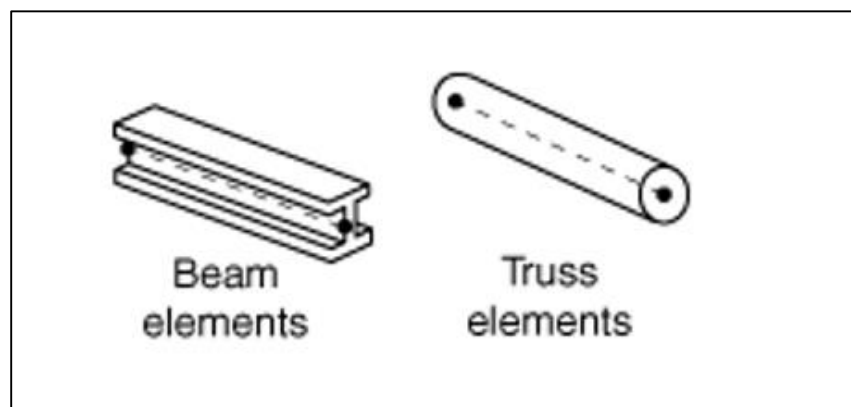

Figure 19: Line element used in FEA

The basic difference between the truss and beam element is that when the truss element can take forces in basic 3 co-ordinates directions (3 degree of freedom) while beam element can take both forces and moment in 6 co-ordinates directions (6 degree of freedom) [22].

The basic two dimensional or plane elements have two basic types. They are triangular and quadrilateral. When the model is meshed with plane elements, forces are applied in their own plane. The simplest planer elements have nodes in their corners and edges between corner nodes are straight. Higher-order elements or quadratic elements have mid-nodes and their edges are curves. Thickness throughout the plane element may be constant or be vary [21].

To the plane stress and plane strain analysis, planer elements with two degree of freedom are used. Many axisymmetric bodies of revolution as radial seals are modeled with planer elements. Another application is that long sections with constant cross sectional area such as a dam. In plane stress cases, stress of normal to plane is zero and strain exists. In Plane strain cases, strain normal to plane is zero and stress is available. Force applied in radial direction to a long tube is a typical example for a plane strain problem [22].

Membrane elements are another category of two dimension planer elements which may have 3 nodes or 4 nodes. Membrane elements are used to model thin membrane layers like fabric, thin metal sheet, etc. Membrane elements cannot transmit rotational degree of freedom and out of plane loading, but transmit only translational degree of freedom. Thickness of membrane element is relatively small to its length and width, and thickness is defined as a fixed parameter [22].

Plate or shell elements have three or four nodes and used to model structures such as pressure vessels, automobile bodies, ship hulls, and aircraft fuselages. plate elements are thicker than membrane elements and generally considered that thickness is one tenth of element's width or length. plate element can translate both translational degree of freedom and rotational degree of freedom. But they can't translate rotation about normal to the element surface that is rotational is not translated in out of plane [18],[21].

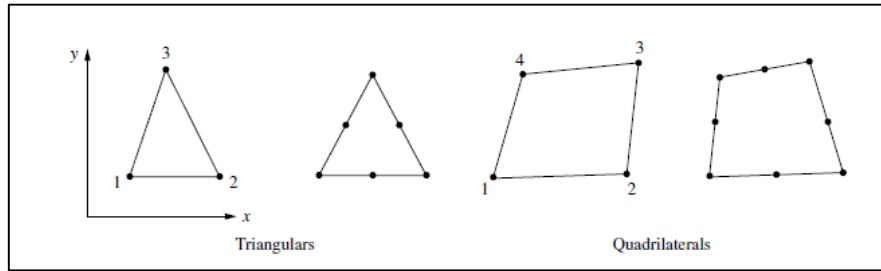

Figure 20: Plate element used in FEA

When it is needed to carry out three dimensional analyses, tetrahedral and hexahedral or brick elements are used. Basic three dimensional elements have only corner nodes and surfaces are straight. Higher order elements have mid edge or mid surface nodes, hence surfaces are curves. These three dimensional elements can transmit only translational degree of freedom [18], [21].

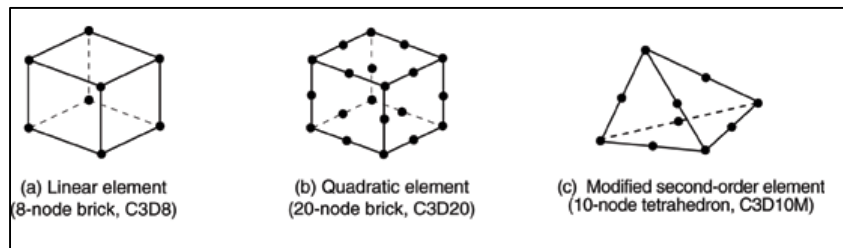

Figure 21: 3D elements used in FEA

For the cases where geometry and loading are axisymmetric, axisymmetric elements are used. These elements are developed by rotating quadrilateral or triangle about a fixed axis located in the plane of the element through 360 degree. These elements convert a 3-D problem to a 2-D problem. When the axisymmetric elements are used, only the cross section of the model is taken in to consideration. Geometry should not be in negative X direction of global co-ordinate system. In post processing,  $\sigma_x$  is given as radial stress,  $\sigma_y$  is given as axial stress, and  $\sigma_z$  is the “hoop” stress [21].

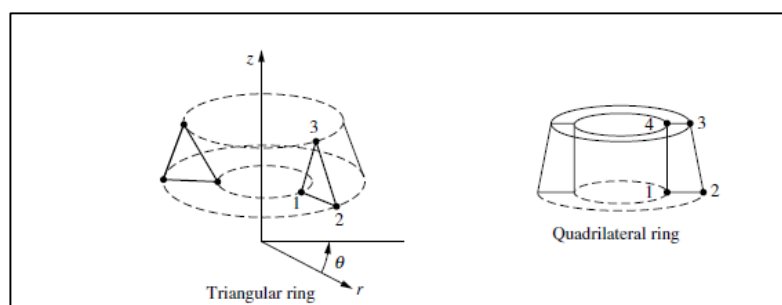

Figure 22: Axisymmetric elements used in FEA

### 2.9.2 . Selection a displacement function

The displacement function is defined to each element by nodal values of the element. Displacement function is taken as linear, quadratic and cubic functions in many cases, since these functions are easy to handle. But it is possible to use trigonometric function also. For a two dimensional elements, displacement function is defined in using the co-ordinates of same plane. Same general displacement function is used for repeatedly each element [21].

### 2.9.3. Define the strain/displacement and stress/strain relationship

Equations for each element is derived using strain/displacement and stress/strain relationship. For the one dimensional case in X direction, strain  $\epsilon_x$  relates with displacement u in the x direction by equation for small strains.

$$\epsilon_x = du/dx$$

The simplest stress/strain relationship is Hooke's law. In the Hooke's law, stress associate with strain and modulus of elasticity which is a material property. Therefore it is very important to material behavior accurately. Equation given below shows the general Hooke's law in x direction for isotropic material [21].

$$\sigma_x = \left\{ \frac{E}{(1 + \nu)(1 - 2\nu)} \right\} \{ \epsilon_x(1 - \nu) + \nu\epsilon_y + \nu\epsilon_z \}$$

$$\sigma_x = \text{Stress in x direction}$$

$$E = \text{modulu of elasticity}$$

$$\nu = \text{Poisson's ratio}$$

### 2.9.4. Derive element stiffness matrix and equations

Basically there are two methods to develop element stiffness matrix and equations. They are direct equilibrium method and work energy method.

#### 2.9.4.1 Direct equilibrium method

Stiffness matrix and element equations relating nodal forces to nodal displacement are obtained using force equilibrium conditions for a basic element, along with force/deformation relationship. This method can be easily applied to bar and beam

elements. The direct equilibrium method is used to define stiffness matrix for element.

For an element, stiffness matrix  $\hat{k}$  relates with matrix  $\hat{f}=\hat{k}\hat{d}$ , where  $\hat{k}$  relates to local coordinate,  $\hat{d}$  relates to nodal displacement in local direction and  $\hat{f}$  is the forces in local direction. This relationship is given accordingly Hook's law. Consider the linear spring element shown in figure 23.

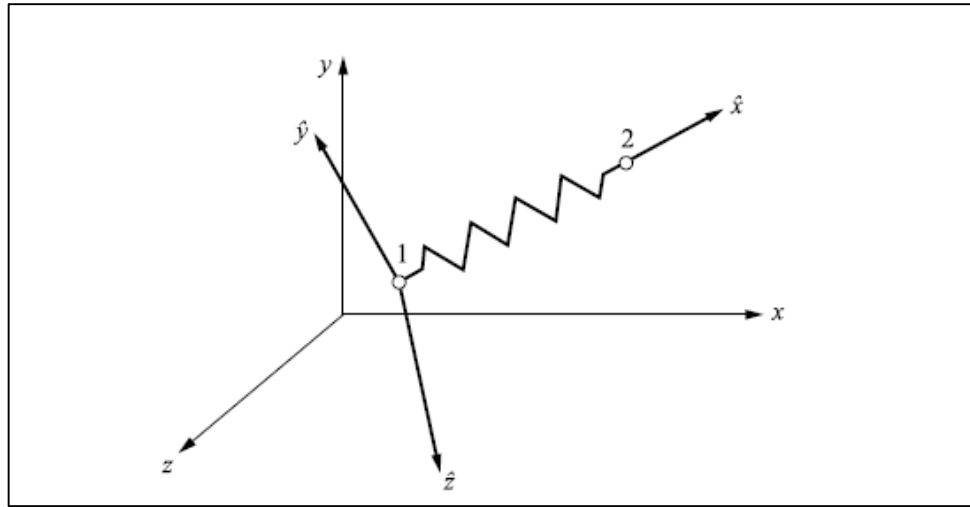

Figure 23:linear spring element

End points 1 and 2 in the elements are called nodes of the element. The local axis is defined along the element axis and, hence local displacements (degree of freedom)  $\hat{d}_{1x}$ ,  $\hat{d}_{2x}$  and local forces  $\hat{f}_{1x}$  and  $\hat{f}_{2x}$  lie along the axis of element. The nodal forces can be related with nodal forces with following matrix relationship [21].

$$\begin{pmatrix} \hat{f}_{1x} \\ \hat{f}_{2x} \end{pmatrix} = \begin{pmatrix} k_{11} & k_{12} \\ k_{21} & k_{22} \end{pmatrix} \begin{pmatrix} \hat{d}_{1x} \\ \hat{d}_{2x} \end{pmatrix}$$

$$\begin{pmatrix} \hat{f}_{1x} \\ \hat{f}_{2x} \end{pmatrix} = AE/L \begin{pmatrix} 1 & -1 \\ -1 & 1 \end{pmatrix} \begin{pmatrix} \hat{d}_{1x} \\ \hat{d}_{2x} \end{pmatrix}$$

Where A,E and L are cross sectional area of the beam, Young's modulus of the beam material and length of the beam respectively.

### 2.9.4.2 Work energy method

Work or energy method are easily applied for developing stiffness matrix to two dimensional or three dimensional applications. Element equation can be easily derived by principal of virtual work(using virtual displacement), and the principal of minimum potential energy.

#### 2.9.4.2.1 The principle of minimum potential energy theorem

A system can be defined as conservative when work done by internal and external forces depends only on the initial and final displacement configuration. Then total potential energy  $\pi_p$  can be expressed in term of displacement  $d$

$$\pi_p = \pi_p(d_1, d_2, \dots, d_n).$$

The total potential energy  $\pi_p$  consist of strain energy defined by  $U$  and potential energy  $\Omega$  [23]. Hence

$$\pi_p = U + \Omega$$

strain energy  $U$  is created when stresses or internal forces form elastic deformation. Potential energy is the capacity of the body forces, surface forces and applied nodal forces to do work through displacement in the structure [23].

According to minimum potential energy theorem, all the geometrically possible shapes that a body can assume, the true one, corresponding to the satisfaction of stable equilibrium of the body, is identified by a minimum value of the total potential energy [21]. According to this definition, it should be satisfied that

$$\frac{\partial \pi_p}{\partial d_i} = 0, i = 1, 2, 3, \dots, n$$

#### 2.9.4.2.2 The principle of virtual work

Thus, the Principle of Virtual Work states that a body is in equilibrium if, and only if, the virtual work of all forces acting on the body is zero [24].

In this definition, word virtual depicts the having the effect of, but not the actual form of. Basically there are two principles under virtual work. First one is principle of virtual displacement, where virtual work is defined as work done by actual forces acting on the body moving through a virtual displacement. Second one is called

principle of virtual forces where virtual is the work done when virtual forces moving through actual displacement. But in many situations, first principle or principle of virtual displacement is used [24].

To prove the principle of virtual work, it is considered a particle under several forces from  $F_1 \dots \dots \dots F_n$  and resultant forces of these forces is  $F_r$ . Virtual displacement  $\delta_y$  is applied to particle as shown below.

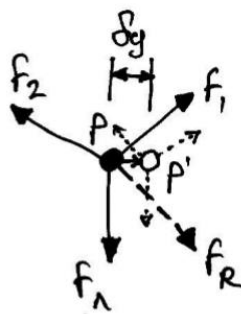

Figure 24: virtual displacement applied on the particle

Virtual work done on the system;

$$\delta W = F_1 \delta_1 + F_2 \delta_2 + F_3 \delta_3 \dots \dots \dots F_n \delta_n = F_r \cdot \delta_{yr}$$

Since particle is in equilibrium,  $F_r = 0$ . Hence  $F_r \cdot \delta_{yr} = 0$

$$F_1 \delta_1 + F_2 \delta_2 + F_3 \delta_3 \dots \dots \dots F_n \delta_n = 0$$

### 2.9.5 Assembly the element equations to obtain the global or total equations

Under this step, global or nodal equilibrium equation is derived by assembling individual element nodal equilibrium equations developed in 2.9.4.1 as follows.

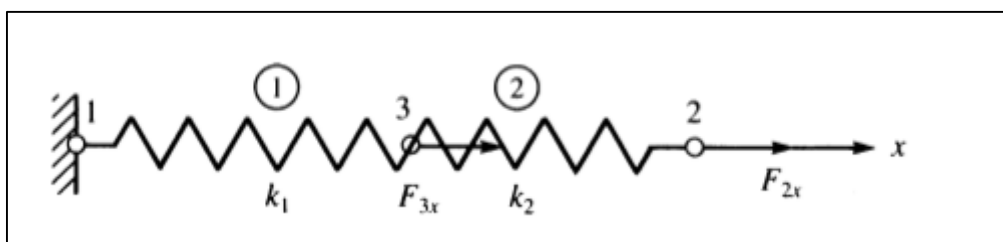

Figure 25: Two spring assembly



First, it is taken two spring assembly for studying direct equilibrium approach for obtaining total stiffness matrix of the assembly. Total assembly is fixed at node 1 and forces  $F_{3x}$  and  $F_{2x}$  are applied at nodes 3 and 2 respectively. Element 1 and 2 have stiffness  $k_1$  and  $k_2$ .

For the element 1, force displacement relationship can be written in X direction

$$f_{1x} = k_1 d_{1x(1)} - k_1 d_{3x(1)}$$

$$f_{3x} = k_1 d_{3x(1)} - k_1 d_{1x(1)}$$

Then, these equations can be written in matrix form as follows,

$$\begin{pmatrix} f_{1x} \\ f_{3x} \end{pmatrix} = \begin{pmatrix} k_1 & -k_1 \\ -k_1 & k_1 \end{pmatrix} \begin{pmatrix} d_{1x(1)} \\ d_{3x(1)} \end{pmatrix}$$

Similarly to element 2,

$$\begin{pmatrix} f_{3x} \\ f_{2x} \end{pmatrix} = \begin{pmatrix} k_2 & -k_2 \\ -k_2 & k_2 \end{pmatrix} \begin{pmatrix} d_{3x(2)} \\ d_{2x(2)} \end{pmatrix}$$

Element 1 and 2 are connected in common node 3 through out the displacement. This is called continuity or compatibility condition. According to compatibility conditions,

$$d_{3x(1)} = d_{3x(2)} = d_{3x}$$

Based on force balance following, equations can be written as,

$$F_{3x} = f_{3x(1)} + f_{3x(2)}$$

$$F_{2x} = f_{2x}$$

$$F_{1x} = f_{1x}$$

By substituting to these equations it is given ,

$$F_{3x} = (-k_1 d_{1x} + k_1 d_{3x}) + (k_2 d_{3x} - k_2 d_{2x})$$

$$F_{2x} = -k_2 d_{3x} + k_2 d_{2x}$$

$$F_{1x} = k_1 d_{1x} - k_1 d_{3x}$$

Above forces are written if matrix form as,

$$\begin{pmatrix} F_{3x} \\ F_{2x} \\ F_{1x} \end{pmatrix} = \begin{pmatrix} k_1 + k_2 & -k_2 & -k_1 \\ -k_2 & k_2 & 0 \\ -k_1 & 0 & k_1 \end{pmatrix} \begin{pmatrix} d_{3x} \\ d_{2x} \\ d_{1x} \end{pmatrix}$$

Now above equations, it is written as

$$\underline{F} = \underline{Kd}$$

Where F is called global nodal force matrix, d is called the global displacement matrix and K is called total or system or global stiffness matrix[21],[25].

Except direct equilibrium approach, special method called direct stiffness method can be used to develop global equations to whole structure [21]. Continuity and compatibility are required any of structures that no tears occur anywhere within the structure.

The direct stiffness method is based on superposition theorem. Following example shows how it is applied to above two spring assembly. Element stiffness matrix developed each element is given below.

$$\underline{k}^{(1)} = \begin{matrix} & \begin{matrix} d_{1x} & d_{3x} \end{matrix} \\ \begin{bmatrix} k_1 & -k_1 \\ -k_1 & k_1 \end{bmatrix} & \begin{matrix} d_{1x} \\ d_{3x} \end{matrix} \end{matrix} \quad \underline{k}^{(2)} = \begin{matrix} & \begin{matrix} d_{3x} & d_{2x} \end{matrix} \\ \begin{bmatrix} k_2 & -k_2 \\ -k_2 & k_2 \end{bmatrix} & \begin{matrix} d_{3x} \\ d_{2x} \end{matrix} \end{matrix}$$

$d_x$  is written above the column and next to the row associated with K.

Element one has deformation in axial direction in node 1 and 3. But element two has axial deformation node 3 and 2. Therefore above two matrices cannot be added or super impose at its original form. To perform superimpose, element stiffness matrix should be changed as if it associate with all the degree of freedom in the structure. Then, rows and columns of zeros are added to stiffness matrix as follows.

For element 1, stiffness matrix is expanded and written as,

$$\begin{pmatrix} f_{1x(1)} \\ f_{2x(1)} \\ f_{3x(1)} \end{pmatrix} = k_1 \begin{matrix} & \begin{matrix} d_{1x} & d_{2x} & d_{3x} \end{matrix} \\ \begin{pmatrix} 1 & 0 & -1 \\ 0 & 0 & 0 \\ -1 & 0 & 1 \end{pmatrix} & \begin{matrix} d_{1x(1)} \\ d_{2x(1)} \\ d_{3x(1)} \end{matrix} \end{matrix}$$

Here  $f_{2x(1)}$  is zero and no contribution from  $d_{2x(1)}$ . Similarly, for element 2

$$\begin{pmatrix} f_{1x(2)} \\ f_{2x(2)} \\ f_{3x(2)} \end{pmatrix} = k_2 \begin{matrix} & \begin{matrix} d_{1x} & d_{2x} & d_{3x} \end{matrix} \\ \begin{pmatrix} 0 & 0 & 0 \\ 0 & 1 & -1 \\ 0 & -1 & 1 \end{pmatrix} & \begin{matrix} d_{1x(2)} \\ d_{2x(2)} \\ d_{3x(2)} \end{matrix} \end{matrix}$$

Force equilibrium at each node can be applied to each node

$$\begin{pmatrix} F_{1x} \\ F_{2x} \\ F_{3x} \end{pmatrix} = \begin{pmatrix} f_{1x(1)} \\ f_{2x(1)} \\ f_{3x(1)} \end{pmatrix} + \begin{pmatrix} f_{1x(2)} \\ f_{2x(2)} \\ f_{3x(2)} \end{pmatrix}$$

Substituting to  $f_{1x(1)}, f_{2x(1)} \dots$  to  $f_{3x(2)}$

$$\begin{pmatrix} F_{1x} \\ F_{2x} \\ F_{3x} \end{pmatrix} = k_1 \begin{pmatrix} 1 & 0 & -1 \\ 0 & 0 & 0 \\ -1 & 0 & 1 \end{pmatrix} \begin{pmatrix} d_{1x(1)} \\ d_{2x(1)} \\ d_{3x(1)} \end{pmatrix} + k_2 \begin{pmatrix} 0 & 0 & 0 \\ 0 & 1 & -1 \\ 0 & -1 & 1 \end{pmatrix} \begin{pmatrix} d_{1x(2)} \\ d_{2x(2)} \\ d_{3x(2)} \end{pmatrix}$$

Then equation can be simplified to;

$$\begin{pmatrix} F_{1x} \\ F_{2x} \\ F_{3x} \end{pmatrix} = \begin{pmatrix} k_1 & 0 & -k_1 \\ 0 & k_2 & -k_2 \\ -k_1 & -k_2 & k_1 + k_2 \end{pmatrix} \begin{pmatrix} d_{1x} \\ d_{2x} \\ d_{3x} \end{pmatrix}$$

### 2.9.6 solve for the unknown degree of freedom or generalized displacement

Equation  $F = kd$  is expanded in matrix form as follows.

$$\begin{Bmatrix} F_1 \\ F_2 \\ \vdots \\ F_n \end{Bmatrix} = \begin{bmatrix} K_{11} & K_{12} & \dots & K_{1n} \\ K_{21} & K_{22} & \dots & K_{2n} \\ \vdots & & & \vdots \\ K_{n1} & K_{n2} & \dots & K_{nn} \end{bmatrix} \begin{Bmatrix} d_1 \\ d_2 \\ \vdots \\ d_n \end{Bmatrix}$$

Where n is the total number of unknown nodal degree of freedom. This equation can be solved by gauss's method (eliminating method) or gauss-seidel method (Iterative method) [4],[6].

In FEA software these two methods are known as direct linear equation solver (use eliminating method) and iterative linear equation solver (use iterative method). Direct iterative method often represent the most time consuming part of the analysis, especially for large models. The storage of the equations occupies the largest part of the disk space during the calculations. Direct solver finds the exact solution to this system of linear equations.

Iterative linear equation solver should be used only for large, well-conditioned models. It is significantly faster than the direct equation solver for large, well-conditioned, blocky structures. This solver uses less storage than the direct solver (memory and disk combined). Since the technique is iterative, a converged solution to a given system of linear equations cannot be ensured at all the time . In such cases when the iterative solver is unable or fail to give a converge solution, model should be modified that may be necessary to improve the convergence behavior [18].

### **2.9.7 solve for the element stress and strain**

After force and displacement secondary important quantities are stress and strain. Following equations can be used to calculate stress and strain.

$$\varepsilon_x = \frac{\partial u}{\partial x}$$

$$\sigma_x = \left\{ \frac{E}{(1 + \nu)(1 - 2\nu)} \right\} \{ \varepsilon_x(1 - \nu) + \nu\varepsilon_y + \nu\varepsilon_z \}$$

### **2.9.8 Interpret the results**

Final goal is to interpret the results. Computer programs use post processors to visualize contours maps, graphs, plots, and, animations. In design process, it is identified area where stress and deformations are higher than designed criteria.

### **2.10 Derivation of the stiffness matrix for a bar element in a local coordinates**

It is not always met beams or trust ofwhich oriental direction is parallel with global X axis. In many situations, oriental direction is incline to global axes. Local coordinates always with the individual element direction and global coordinates are selected to whole structure in a convenient manner [26].

As following figure 26 shows, angle between local axis and global direction is  $\varphi$ .

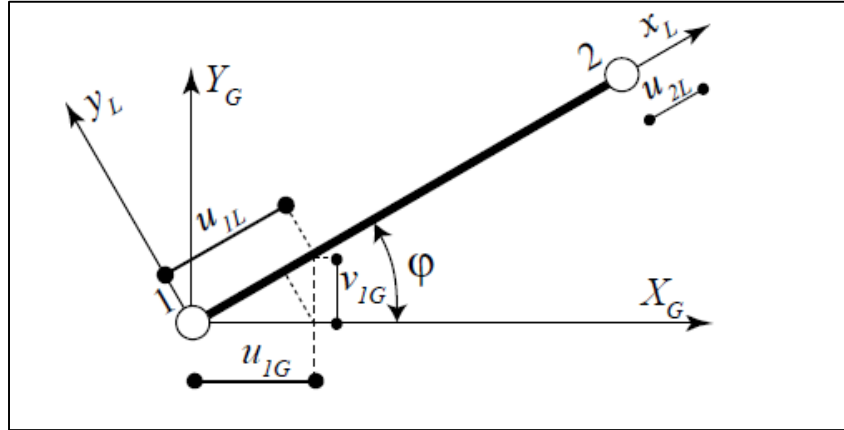

Figure 26: Local displacement of beam

$u_{1G}$  and  $u_{2G}$  are displacement of node 1 and 2 in global axis  $X_G$ .  $v_{1G}$  and  $v_{2G}$  are displacement of node 1 and 2 in global axis  $Y_G$ .

$u_{1L}$  is the displacement of node 1 in direction of local axis  $X_L$ .

$$u_{1L} = u_{1G} \cos\phi + v_{1G} \sin\phi$$

And similar for node 2;  $u_{2L} = u_{2G} \cos\phi + v_{2G} \sin\phi$

It can be named simply,  $c = \cos\phi$  and  $s = \sin\phi$ . Then it can be written as

$$\begin{Bmatrix} u_{1L} \\ u_{2L} \end{Bmatrix} = \begin{bmatrix} c & s \\ 0 & c \end{bmatrix} \begin{Bmatrix} u_{1G} \\ v_{1G} \\ u_{2G} \\ v_{2G} \end{Bmatrix} \quad (15)$$

Then matrix  $[T] = \begin{bmatrix} c & s \\ 0 & c \end{bmatrix}$  is called the transformation matrix. Then it can be written as,

$$\{U_L\} = [T]\{U_G\} \quad (16)$$

here  $u_G$  is global nodal displacement vector.

Figure 27 shows the nodal forces in local direction applied on the above beam.

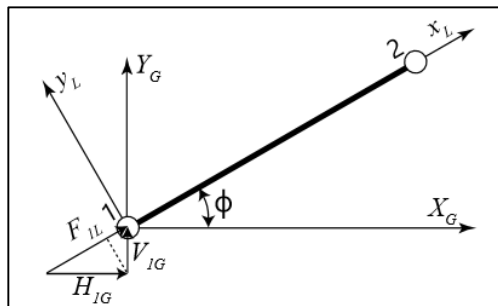

Figure 27: Nodal forces applied in local direction

Forces  $H_{1G}$  and  $H_{2G}$  are the nodal forces of node 1 and 2 in  $X_G$  global direction. Forces  $V_{1G}$  and  $V_{2G}$  are the nodal forces of node 1 and 2 in  $Y_G$  global direction. Then nodal forces in node 1 and 2 can be written as follows.

$$F_{1L} = H_{1G} \cdot \cos\phi + V_{1G} \cdot \sin\phi$$

$$F_{2L} = H_{2G} \cdot \cos\phi + V_{2G} \cdot \sin\phi$$

Then following matrix equation can be easily written.

$$\begin{Bmatrix} F_{1L} \\ F_{2L} \end{Bmatrix} = \begin{bmatrix} \cos\phi & \sin\phi \\ -\sin\phi & \cos\phi \end{bmatrix} \begin{Bmatrix} H_{1G} \\ H_{2G} \\ V_{1G} \\ V_{2G} \end{Bmatrix} \quad (17)$$

By using equation 17, it can be written as

$$\{F_L\} = [T]\{F_G\} \quad (18)$$

But for the local level, it can be written

$$[K_L]\{U_L\} = \{F_L\} \quad (19)$$

where  $[K_L]$  is local stiffness matrix. Combining equation 17, 18 and 19, it is written as ,

$$[K_L] \cdot [T] \cdot \{U_G\} = [T]\{F_G\} \quad (20)$$

both members of equation 20 is multiplied by transpose of  $[T]$  or  $[T]^T$ , then

$$[T]^T \cdot [K_L] \cdot [T] \cdot \{U_G\} = [T]^T \cdot [T]\{F_G\} \quad (21)$$

Then it is given finally  $[K_G] \cdot \{U_G\} = \{F_G\}$ , when  $[K_G] = [T]^T \cdot [K_L] \cdot [T]$ . (22)

$[T]^T \cdot [T] =$  identity matrix, because  $[T]$  is orthogonal. [27]

According to the section 2.9.4.1, and relationship of matrix T, global stiffness matrix  $[K_G]$  can be calculated by equation 22. Hence

$$[K_G] = \begin{bmatrix} C^2 & CS & -C^2-CS \\ CS & S^2 & -CS-S^2 \\ -C^2-CS & C^2 & CS \\ -CS-S^2 & CS & S^2 \end{bmatrix} \text{---(23)}$$

### 2.11 Derivation of the constant-strain triangular element stiffness matrix and equation

The way of developing stiffness matrix for two dimensional elements (plane elements) is described by below section. plane elements are called constant-strain triangular (CST) elements since elements have constant strain throughout it. The derivation of CST elements is the simplest among the two-dimensional elements.

Stiffness matrix of the CST elements is derived using principle of minimum potential energy since it is the most feasible method to derive stiffness matrix for both two dimensional and three dimensional FEA cases.

Nodes of the triangular elements are i, j and m respectively. These nodes have two degree of freedom. Field function of X and Y directions are taken as linear function as follows.

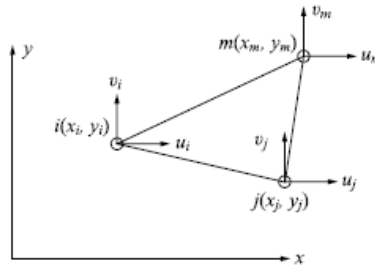

Figure 28: displacement in a CST element

$$u_{(x,y)} = [1 \ x \ y] \begin{pmatrix} a_1 \\ a_2 \\ a_3 \end{pmatrix}$$

$$v_{(x,y)} = [1 \ x \ y] \begin{pmatrix} a_4 \\ a_5 \\ a_6 \end{pmatrix}$$

Next element co-ordinates at i, j and m are applied to above equations and results yield to,

$$\begin{pmatrix} u_i \\ u_j \\ u_m \end{pmatrix} = \begin{bmatrix} 1 & x_i & y_i \\ 1 & x_j & y_j \\ 1 & x_m & y_m \end{bmatrix} \begin{pmatrix} a_1 \\ a_2 \\ a_3 \end{pmatrix}$$

$$\begin{pmatrix} v_i \\ v_j \\ v_m \end{pmatrix} = \begin{bmatrix} 1 & x_i & y_i \\ 1 & x_j & y_j \\ 1 & x_m & y_m \end{bmatrix} \begin{pmatrix} a_4 \\ a_5 \\ a_6 \end{pmatrix}$$

Solving above two equations, unknown constant  $a_1$  to  $a_6$  can be found as,

$$\begin{pmatrix} a_1 \\ a_2 \\ a_3 \end{pmatrix} = [x]^{-1} \begin{pmatrix} u_i \\ u_j \\ u_m \end{pmatrix}$$

$$\begin{pmatrix} a_4 \\ a_5 \\ a_6 \end{pmatrix} = [x]^{-1} \begin{pmatrix} v_i \\ v_j \\ v_m \end{pmatrix}$$

Since  $(x)$  is a 3X3 matrix, cofactor method can be used to get the inverse of matrix  $x$ .

$$[x]^{-1} = 1/2A \begin{bmatrix} \alpha_i & \alpha_j & \alpha_m \\ \beta_i & \beta_j & \beta_m \\ \gamma_i & \gamma_j & \gamma_m \end{bmatrix}$$

$$2A = \begin{vmatrix} 1 & x_i & y_i \\ 1 & x_j & y_j \\ 1 & x_m & y_m \end{vmatrix}$$

$$2A = x_i(y_i - y_m) + x_j(y_m - y_i) + x_m(y_i - y_j)$$

After determine inverse of matrix  $x$ ,  $a_1$ ,  $a_2$  and  $a_3$  can be found as follows (cofactor method).

$$\alpha_i = x_j y_m - y_j x_m, \quad \alpha_j = y_j x_m - x_i y_m, \quad \alpha_m = x_i y_j - y_i x_j,$$

$$\beta_i = y_j - y_m, \quad \beta_j = y_m - y_i, \quad \beta_m = y_i - y_j,$$

$$\gamma_i = x_m - x_j, \quad \gamma_j = x_i - x_m, \quad \gamma_m = x_j - x_i,$$

$$\begin{pmatrix} a_1 \\ a_2 \\ a_3 \end{pmatrix} = 1/2A \begin{bmatrix} \alpha_i & \alpha_j & \alpha_m \\ \beta_i & \beta_j & \beta_m \\ \gamma_i & \gamma_j & \gamma_m \end{bmatrix} \begin{pmatrix} u_i \\ u_j \\ u_m \end{pmatrix}$$



Similarly  $a_4$ ,  $a_5$  and  $a_6$  also can be obtained as

$$\begin{pmatrix} a_4 \\ a_5 \\ a_6 \end{pmatrix} = 1/2A \begin{bmatrix} \alpha_i & \alpha_j & \alpha_m \\ \beta_i & \beta_j & \beta_m \\ \gamma_i & \gamma_j & \gamma_m \end{bmatrix} \begin{pmatrix} v_i \\ v_j \\ v_m \end{pmatrix}$$

in general for  $\{u\}$  can be written as  $\{u\} = [1 \quad x \quad y] \begin{bmatrix} a_1 \\ a_2 \\ a_3 \end{bmatrix}$

by substituting to  $a_1$ ,  $a_2$  and  $a_3$  it is given that,

$$\{u\} = 1/2A [1 \quad x \quad y] \begin{bmatrix} \alpha_i & \alpha_j & \alpha_m \\ \beta_i & \beta_j & \beta_m \\ \gamma_i & \gamma_j & \gamma_m \end{bmatrix} \begin{pmatrix} u_i \\ u_j \\ u_m \end{pmatrix}$$

This is simplified to  $\{u\} = 1/2A [1 \quad x \quad y] \begin{Bmatrix} \alpha_i u_i + \alpha_j u_j + \alpha_m u_m \\ \beta_i u_i + \beta_j u_j + \beta_m u_m \\ \gamma_i u_i + \gamma_j u_j + \gamma_m u_m \end{Bmatrix}$

By multiplying two matrices,  $\{u\}$  is given by

$$\{u_{(x,y)}\} = 1/2A \{(\alpha_i + \beta_i x + \gamma_i y)u_i + (\alpha_j + \beta_j x + \gamma_j y)u_j + (\alpha_m + \beta_m x + \gamma_m y)u_m\} \text{-----}(24)$$

Similarly expression can be taken to  $\{v_{(x,y)}\}$  also

$$\{v_{(x,y)}\} = 1/2A \{(\alpha_i + \beta_i x + \gamma_i y)v_i + (\alpha_j + \beta_j x + \gamma_j y)v_j + (\alpha_m + \beta_m x + \gamma_m y)v_m\} \text{-----}(25)$$

For the simplicity it is defined,

$$N_i = 1/2A(\alpha_i + \beta_i x + \gamma_i y)$$

$$N_j = 1/2A(\alpha_j + \beta_j x + \gamma_j y)$$

$$N_m = 1/2A(\alpha_m + \beta_m x + \gamma_m y)$$

Then above equations for can be re-written as

$$\{u_{(x,y)}\} = \{N_i u_i + N_j u_j + N_m u_m\}$$

$$\{v_{(x,y)}\} = \{N_i v_i + N_j v_j + N_m v_m\}$$

For the two dimensional cases element strain is given by the equations below.

$$\varepsilon = \begin{Bmatrix} \varepsilon_x \\ \varepsilon_y \\ \gamma_{xy} \end{Bmatrix} = \begin{Bmatrix} \frac{\partial u}{\partial x} \\ \frac{\partial v}{\partial y} \\ \left( \frac{\partial u}{\partial y} + \frac{\partial v}{\partial x} \right) \end{Bmatrix}$$

By equation 24 and 25  $\varepsilon$  can be written in matrix format as

$$\varepsilon = \begin{bmatrix} \beta_i & 0 & \beta_j & 0 & \beta_m & 0 \\ 0 & \gamma_i & 0 & \gamma_i & 0 & \gamma_i \\ \gamma_i & \beta_i & \gamma_j & \beta_j & \gamma_m & \beta_m \end{bmatrix} \begin{pmatrix} u_i \\ v_j \\ u_j \\ v_i \\ u_m \\ v_m \end{pmatrix}$$

Above matrix is simplified as following way.

$$\varepsilon = [B](d) \text{-----} (26)$$

Where

$$B = \begin{bmatrix} \beta_i & 0 & \beta_j & 0 & \beta_m & 0 \\ 0 & \gamma_i & 0 & \gamma_i & 0 & \gamma_i \\ \gamma_i & \beta_i & \gamma_j & \beta_j & \gamma_m & \beta_m \end{bmatrix}$$

B matrix is independent of variable x and variable y co-ordinates. Therefore strain on an element does not vary with element's x and y co-ordinates. Hence strain is constant and called as constant strain triangular element. (CST)

According to hook's law in-plane stress/strain relationship for an isotropic element is given below.

$$\{\sigma\} = \begin{Bmatrix} \sigma_x \\ \sigma_y \\ \sigma_{xy} \end{Bmatrix} = [D]\{\varepsilon\} \text{-----} (27)$$

From equation 26,

$$\{\sigma\} = [D][B](d) \text{-----} (28)$$

Where D for plain strain case;

$$D = E/(1 + \nu)(1 - 2\nu) \begin{bmatrix} 1 - \nu & \nu & 0 \\ \nu & 1 - \nu & 0 \\ 0 & 0 & (1 - 2\nu)/2 \end{bmatrix}$$

According to the principle of minimum potential energy, total potential of a system can be expressed as;

$$\pi p = U + \Omega b + \Omega p + \Omega s \text{ ————— (29)}$$

U- strain energy,  $\Omega b$ -potential energy due to body force,  $\Omega p$ -potential energy due to concentrated force,  $\Omega s$ -potential energy due to surface force.

For the static cases potential energy due to body force (inertia) is negligible. Surface forces can be concentrated to nodes. Therefore potential energy due to nodal forces;

$$\Omega p = -\{d\}^T \{f\} \text{ ————— (29)}$$

Using equation 26,28  $U = 1/2 \iiint \{d\}^T [B^T] [D] [B] \{d\} dV \text{ ————— (30)}$

According to minimum potential energy theorem,

$$\frac{\partial \pi p}{\partial \{d\}} = 0$$

Using equation 29 and 30,

$$\frac{\partial \pi p}{\partial \{d\}} = \iiint [B^T] [D] [B] dV \{d\} - \{f\} = 0$$

$$\iiint [B^T] [D] [B] dV \{d\} = \{f\} \text{ ————— (31)}$$

From equation 31 stiffness matrix [K] can be defined as,

$$[K] = \iiint [B^T] [D] [B] dV$$

For an element which has constant thickness t and are A, stiffness matrix [K] is converted as [28],

$$[K] = tA [B^T] [D] [B] \text{ ————— (32)}$$

## 2.12 Cofactor method (Adjoining method) to determine the inverse of a matrix

Cofactor method is useful to determine the inverse of smaller-order square matrices. If matrix  $A$  is  $n \times n$  order,  $A_{ij}$  is a submatrix of  $A$  with size  $(n-1) \times (n-1)$  and  $A_{ij}$  is obtained by deleting  $A$ 's  $i^{th}$  row and  $j^{th}$  column [29].

Then the matrix  $CofA = ((-1)^{i+j} \det(A_{ij}))$

When an inverse matrix is found of matrix  $A$ , this theorem says that inverse is equal to transpose of cofactor matrix and divided by determinant. It is used name adjugate or adjoint to denote the cofactor matrix. Then inverse of  $A$  can be found by one divided by the determinant of  $A$  times the adjoint or adjugate of the  $A$  [30].

## 2.13 Equation of elasticity

### 2.13.1 differential equation for equilibrium

For the simple explanation, it is considered a plane element which has normal stresses  $\sigma_x, \sigma_y$  in  $x$  and  $y$  directions respectively and in-plane shear stress  $\tau_{xy}$ . These stresses are acted per unit area. Body forces acting on the plane element are  $X_b$  and  $Y_b$  per unit volume. It is assumed that stress is varied from one face to another opposite face.

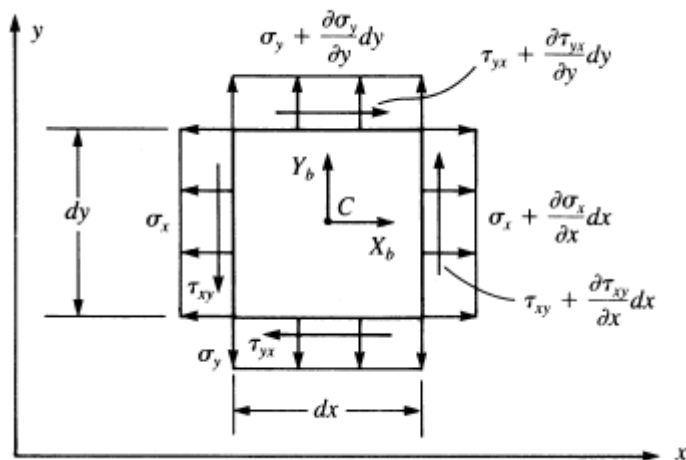

Figure 29: stress tensors on plane element

Stress acts on the left vertical face is  $\sigma_x$  and stress acts on the right vertical face is  $\sigma_x + \left(\frac{\partial \sigma_x}{\partial x}\right) dx$ . Element has unit thickness. Getting summation of forces in x direction,  $\sum F_x=0$ ;

$$\left( \sigma_x + \left(\frac{\partial \sigma_x}{\partial x}\right) dx \right) dy(1) - \sigma_x dy(1) + X_b dx dy(1) + \left( \tau_{yx} + \left(\frac{\partial \tau_{yx}}{\partial y}\right) dy \right) dx(1) - \tau_{yx} dx(1) = 0$$

By simplifying the equations

$$\frac{\partial \sigma_x}{\partial x} + \frac{\partial \tau_{yx}}{\partial y} + X_b = 0$$

Similarly considering equilibrium in y direction

$$\frac{\partial \sigma_y}{\partial y} + \frac{\partial \tau_{xy}}{\partial x} + Y_b = 0$$

Taking the moment about point C,  $\sum M_x=0$ ;

$$\tau_{xy} dy(1) dx/2 + \left( \tau_{xy} + \frac{\partial \tau_{xy}}{\partial x} dx \right) dx/2 - \tau_{yx} dx(1) dy/2 - \left( \tau_{yx} + \frac{\partial \tau_{yx}}{\partial y} dy \right) dy/2 = 0$$

Simplifying and neglecting higher order terms  $\tau_{xy} = \tau_{yx}$

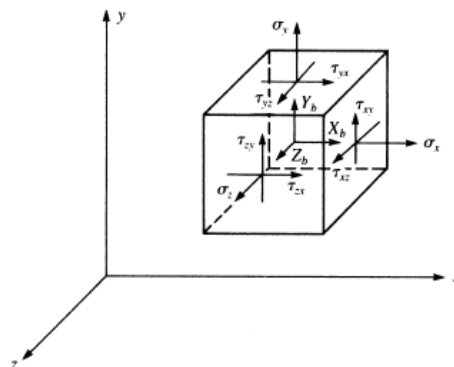

Figure 30: stress elements in three dimensional case

For the three dimensional cases additional stresses  $\sigma_z$ ,  $\tau_{xz}$  and  $\tau_{yz}$  come in to picture (Fig 30). Therefore with a straight forward procedure above equations can be extended for three dimensional cases as follows [11].

$$\frac{\partial \sigma_x}{\partial x} + \frac{\partial \tau_{yx}}{\partial y} + \frac{\partial \tau_{zx}}{\partial z} + X_b = 0$$

$$\frac{\partial \tau_{xy}}{\partial x} + \frac{\partial \sigma_y}{\partial y} + \frac{\partial \tau_{zy}}{\partial z} + Y_b = 0$$

$$\frac{\partial \tau_{xz}}{\partial x} + \frac{\partial \tau_{yz}}{\partial y} + \frac{\partial \sigma_z}{\partial z} + Z_b = 0$$

And  $\tau_{xy} = \tau_{yx}$ ,  $\tau_{xz} = \tau_{zx}$ ,  $\tau_{yz} = \tau_{zy}$

### 2.13.2 Strain/Displacement and compatibility equations

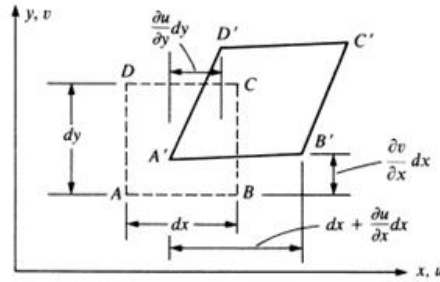

Figure 31: differential element before and after deformation

Consider the elements of which unreformed state by dashed line and deformed state by solid lines. AB line in the elements becomes A'B' after deformation. The displacement in the x and y directions are u and v respectively. According to the definition of engineering normal strain, it can be found by dividing the change of length of AB by original length of AB. This formula is given below.

Strain in x direction =  $(A'B' - AB) / AB$

$$AB = dx$$

$$(A'B')^2 = \left( dx + \frac{\partial u}{\partial x} dx \right)^2 + \left( \frac{\partial v}{\partial x} dx \right)^2$$

Negligting the higherorder term  $\left(\frac{\partial v}{\partial x} dx\right)^2$ ;  $A'B' = \left(dx + \frac{\partial u}{\partial x} dx\right)$

Then according to the definition of engineering normal strain;

$$\varepsilon_x = \frac{\partial u}{\partial x}$$

Then according to the line AD in the y direction

$$\varepsilon_y = \frac{\partial v}{\partial y}$$

Change of angle between two lines AB and AD is known as the shear strain. Originally angle between AB and AD is a right angle. Therefore  $\gamma_{xy}$  is the collection of two angles and it is given by

$$\gamma_{xy} = \frac{\partial u}{\partial y} + \frac{\partial v}{\partial x}$$

In the three dimensional cases, there is displacement w in the z direction and equations derived to two dimensional cases can be extended to three dimensional cases. Then following equations can be written [3].

$$\varepsilon_z = \frac{\partial w}{\partial z}$$

$$\gamma_{xy} = \frac{\partial u}{\partial z} + \frac{\partial w}{\partial x}$$

$$\gamma_{yz} = \frac{\partial v}{\partial z} + \frac{\partial w}{\partial y}$$

### 2.13.3 Stress/strain relationship

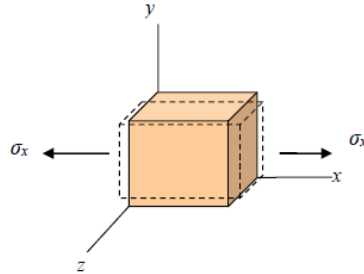

Figure 32: Deformation of 3D element for tensile stress in x direction

As figure 32 shows, 3D element is subjected to tensile stress  $\sigma_x$ . Then element get an extension in x direction. By the Hooke's law,

$$\epsilon'_x = \frac{\sigma_x}{E}$$

Simultaneously element has a contraction in both y and z direction. The Poisson's ratio ( $\nu$ ) is known as the ratio of the transverse strain to the strain in the longitudinal direction [3].

According to the definition of Poisson's ratio

$$\epsilon_y = \epsilon_z = -\frac{\nu\sigma_x}{E}$$

Then total strain due to  $\sigma_x$  is  $\epsilon_x = \epsilon'_x + \epsilon_y + \epsilon_z$

$$\text{Finally it can be shown that, } \epsilon_x = 1/E[\sigma_x - \nu(\sigma_y + \sigma_z)] \text{-----(33)}$$

Similarity following relationship can be found.

$$\epsilon_y = 1/E[\sigma_y - \nu(\sigma_z + \sigma_x)] \text{-----(34)}$$

$$\epsilon_z = 1/E[\sigma_z - \nu(\sigma_x + \sigma_y)] \text{-----(35)}$$

General Hook's law relationship can be used for shear stress and strain relationship as follows.

$$\tau = G\gamma$$



G is the shear modulus. Then shear stress in different directions are written as

$$\tau_{xy} = G\gamma_{xy}$$

$$\tau_{yz} = G\gamma_{yz}$$

$$\tau_{zx} = G\gamma_{zx}$$

Then shear stress is written under following form (Eqn;36-38) by taking relationship

$$G = \frac{E}{2(1 + \nu)}$$

$$\tau_{xy} = \frac{E}{(1+\nu)(1-2\nu)} X \frac{(1-2\nu)}{2} X \gamma_{xy} \text{-----(36)}$$

$$\tau_{yz} = \frac{E}{(1+\nu)(1-2\nu)} X \frac{(1-2\nu)}{2} X \gamma_{yz} \text{-----(37)}$$

$$\tau_{zx} = \frac{E}{(1+\nu)(1-2\nu)} X \frac{(1-2\nu)}{2} X \gamma_{zx} \text{-----(38)}$$

Then equations 33 to 38 can be written in matrix format as [3]

$$\begin{Bmatrix} \sigma_x \\ \sigma_y \\ \sigma_z \\ \tau_{xy} \\ \tau_{yz} \\ \tau_{zx} \end{Bmatrix} = E/(1 + \nu)(1 - 2\nu) \begin{bmatrix} (1 - \nu) & \nu & \nu & 0 & 0 & 0 \\ \nu & (1 - \nu) & \nu & 0 & 0 & 0 \\ \nu & \nu & (1 - \nu) & 0 & 0 & 0 \\ 0 & 0 & 0 & (1 - 2\nu)/2 & 0 & 0 \\ 0 & 0 & 0 & 0 & (1 - 2\nu)/2 & 0 \\ 0 & 0 & 0 & 0 & 0 & (1 - 2\nu) \end{bmatrix} \begin{Bmatrix} \varepsilon_x \\ \varepsilon_y \\ \varepsilon_z \\ \gamma_{xy} \\ \gamma_{yz} \\ \gamma_{zx} \end{Bmatrix}$$

In plane stress condition  $\sigma_z, \tau_{xz}$  and  $\tau_{yz}$  are assumed to be zero. For plane strain problems  $\varepsilon_z, \gamma_{yz}$  and  $\gamma_{xz}$  are assumed be zero [21].

### 3. INTRODUCTION OF VIRTUAL CONSTRAINTS

#### 3.1 Floating structure

If constraints to a system subjected to external non constrained forces/moments is provided in such a way that its configuration cannot be changed with respect to a reference frame without affecting the stress-strain in the system then such constraints could be identified as non-floating constraints (or supports). If configuration could be changed without affecting the stress-strain in the system then such constraints are known as floating constraints.

With non-floating constraints the displacements of the system with respect to a reference frame will be unique. With floating constraints the displacements will have many solutions.( in parametric form)

Then it is clear that if the numerical solving procedure in the software to perform the constraints should be non-floating type.

#### 3.2 identification of floating, non-floating constraints by kinematics method

If the constraint are floating type as arbitrary minute change of the configuration of the object is possible without changing the displacements (linear/rotational) at constraints. If the constraints are non-floating type such change is not possible [31].

any arbitrary change of configuration of a 'rigid' object could be represented on a linear displacement ( $\Delta x\underline{i} + \Delta y\underline{j} + \Delta z\underline{k}$ ) of an arbitrary point ( $x_0, y_0, z_0$ ) fixed with the object and with a rotation ( $\delta\theta$ ) of the object around a particular axis passing through that point. Then the new position vector ( $\underline{p}'$ ) of a point of which the original position was  $\underline{p}(x, y, z)$  will be given by,

$$\underline{p}' = \underline{p} + \Delta x\underline{i} + \Delta y\underline{j} + \Delta z\underline{k} + Q$$

Where  $Q = qpq^{-1}$  a quaternion with real part in zero and  $q = \cos\left(\frac{\theta}{2}\right) + [u_x\underline{i} + u_y\underline{j} + u_z\underline{k}] \sin\left(\frac{\theta}{2}\right)$  and  $u_x\underline{i} + u_y\underline{j} + u_z\underline{k}$  is the unit vector in the direction of the line.

$$p = (x - x_o)\underline{i} + (y - y_o)\underline{j} + (z - z_o)\underline{k}$$

Now if small changes  $\delta x\underline{i} + \delta y\underline{j} + \delta z\underline{k}$  and  $\delta\theta$  is done. Small change in the position vector  $\underline{p}$  is

$$\delta p = \delta x\underline{i} + \delta y\underline{j} + \delta z\underline{k} + \frac{\partial q}{\partial \theta} \delta \theta$$

And if point p(x, y, z) is linearly constrained in particular direction resolution of  $\delta p$  in these directions should be zero. Also if p(x, y, z) is rotationally constrained in particular direction resolution of  $(u_x\underline{i} + u_y\underline{j} + u_z\underline{k}) \delta\theta$  in those direction also should be zero. Now considering all the constrains if it is possible to find out  $(u_x\underline{i} + u_y\underline{j} + u_z\underline{k})$  subjected to above conditions, then the those constraints are of ‘floating type’. Then additional constraint has to be introduce such a way that they will not apply any force/moment on the system and it is unable to find  $(u_x\underline{i} + u_y\underline{j} + u_z\underline{k})$ .

### 3.3 identification of floating, non-floating constraints by static method

In this method it is checked whether the constraints could withstand (or balance) any force/moment system applied on the system in addition to the original force/moment, that is whether the constraints could withstand (or balance) any force/moment on the system, if so the constraints are non-floating. Otherwise floating. If the constraints are ‘floating’ then additional constraints (virtual constraints) has to be introduced in such a way that they will convert the system to a non-floating type and it should be ‘statically’ proved that no force/moment are applied on the system by these when the original force/moment system is applied on the system.

Below equilibrium structure (Figure 33) is subjected external force  $P_i$  and moment  $M_i$ . Force  $P_i$  can be divided to  $F_x, F_y$  and  $F_z$  components and moment  $M_i$  is divided to  $M_x, M_y$  and  $M_z$  components. Then supports are applied at (1,0,0) and (0,0,0) points. At (1,0,0) point , Z direction is restricted and reaction force at point (1,0,0) in Z direction is  $f_{z3}$ . At (0,0,0) point , X,Y and Z directions are restricted and reaction forces at point (0,0,0) are  $f_{x1}, f_{y1}$  and  $f_{z1}$ .

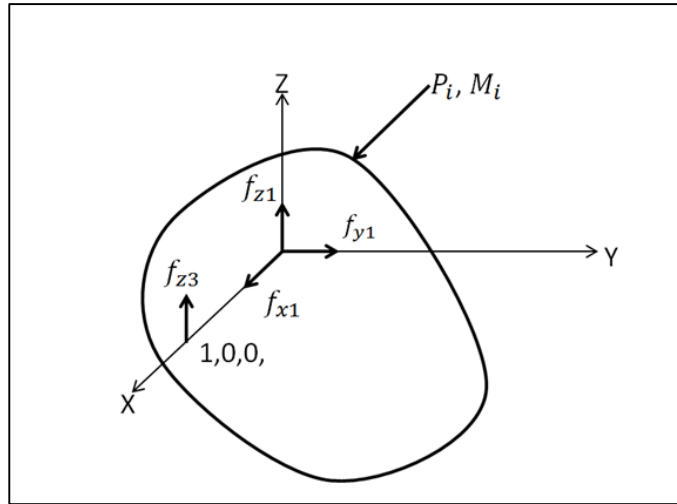

Figure 33: Supports on a body

Then newton's second law is applied in X,Y and Z directions.

$$\left. \begin{aligned} f_{x1} &= -F_X \\ f_{y1} &= -F_Y \\ f_{z1} &= -F_Z \end{aligned} \right\} \text{--- (39)}$$

Taking the moment around point (0,0,0)

$$\left. \begin{aligned} 0 &= M_x \\ f_{z3}X1 &= M_y \\ 0 &= -M_z \end{aligned} \right\} \text{--- (40)}$$

Now another external force and moment are applied on the equilibrium system (Figure 34). New resultant forces are  $F_{xN}$ ,  $F_{yN}$  and  $F_{zN}$  in x, y and z direction respectively. New resultant moments are  $M_{xN}$ ,  $M_{yN}$  and  $M_{zN}$  around x, y and z axes respectively.

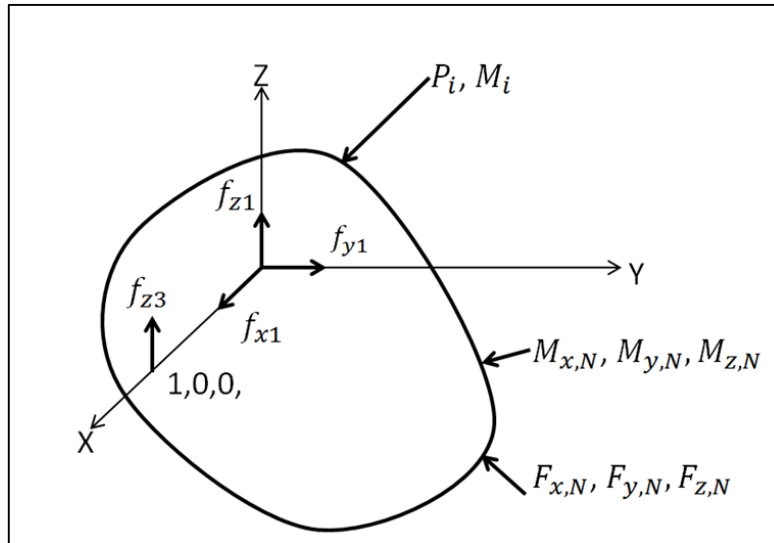

Figure 34: System with new external forces and moment

Then Newton's second law is applied to system. Taking the moment about x axis, it gives following equation.

$$M_{xN} + 0 \neq 0$$

Hence, after new forces and moments are introduced, system become unstable. Therefore this is a floating system. It is equilibrium only a specific set of external forces and moments.

Now another constrained is applied at point (1,1,1) (Figure 35) where y and z directions are restricted and reaction forces at point (1,1,1) in x and y direction are  $f_{x2}, f_{y2}$ .

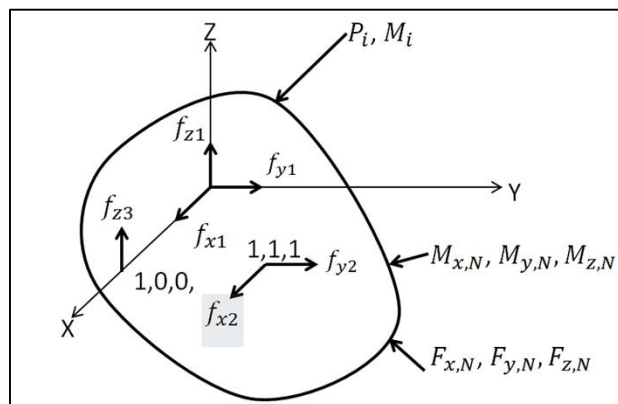

Figure 35: System with new constraint

Then newton's second law is applied in X,Y and Z directions.

$$\left. \begin{aligned} f_{x1} + f_{x2} &= -F_{xN} \\ f_{y2} + f_{y1} &= -F_{yN} \\ f_{z3} + f_{z1} &= -F_{zN} \end{aligned} \right\} (41)$$

Takin the moment around point (0,0,0)

$$\left. \begin{aligned} f_{y2}X1 &= M_{xN} \\ -f_{z3}X1 + f_{x2}X1 &= -M_{yN} \\ -f_{x2}X1 + f_{y2}X1 &= -M_{zN} \end{aligned} \right\} (42)$$

According to equation 41 and 42, system is equilibrium for any kind of external forces and moment after constraint is applied at (1,1,1,) point.

Now external new forces and moments are removed and constraint at point (1,1,1) is kept as it is.

Then newton's second law is applied in X,Y and Z directions.

$$\left. \begin{aligned} f_{x1} + f_{x2} &= -F_x \\ f_{y2} + f_{y1} &= -F_y \\ f_{z3} + f_{z1} &= -F_z \end{aligned} \right\} (43)$$

Takin the moment around point (0,0,0)

$$\left. \begin{aligned} f_{y2}X1 &= M_x \\ -f_{z3}X1 + f_{x2}X1 &= -M_y \\ -f_{x2}X1 + f_{y2}X1 &= -M_z \end{aligned} \right\} (44)$$

Then, relationship built up in equation 40 is applied to equation 44. it results,

$$f_{y2} = 0$$

$$f_{x2} = 0$$

To sum up, externally applied constraint at point (1,1,1) can make the system equilibrium for any external forces and moments. When original forces and moments act on the system, reaction forces generated at constraint of point (1,1,1) is zero. Therefore constraint at (1,1,1) is a virtual constraint. Under these constraint, system can be analyzed by any computer package.

After define virtual constrained for floating system, three case studies were done using concept of virtual constraint. Under these case studies, one static system and two dynamic systems were taken in to account. All the systems were floating system and virtual constraints were applied to find stresses, strain and deformations. Section 3.3.1, 3.3.2 and 3.3.3 provides detail description about the analysis.

### **3.3.1 Use virtual support to analyses roof structure of Kulasinghe auditorium in nerd center**

Roof structure of Kulasinghe auditorium can be concerned as a floating structure because it has no supports and has just touched with columns. The main reason for not to having fix mounting with columns is that preventing transfer bending forces to columns when wing forces act on roof in horizontal direction [32].



Figure 36: Roof of Kulasinghe auditorium



### 3.3.1.1 FEA Model of roof structure

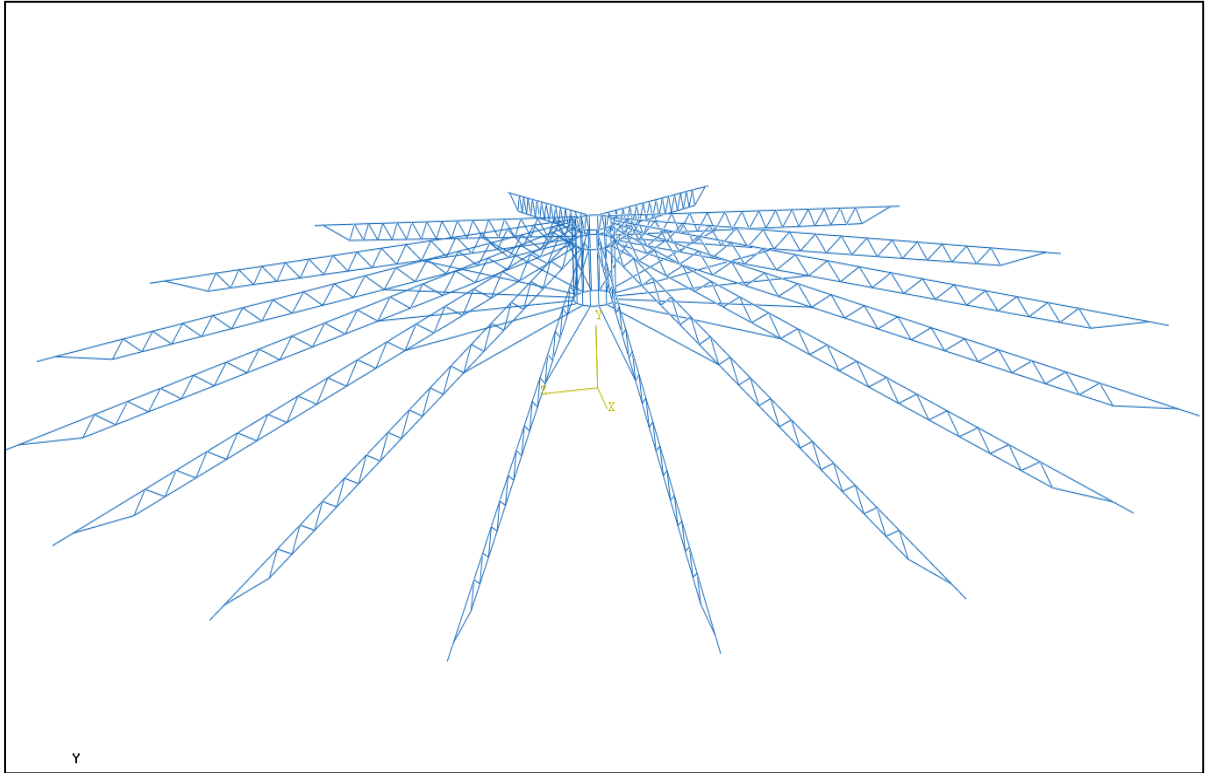

Figure 37:FEA model of structure

As figure 37 shows, FEA model of roof structure was created in Abaqus pre-processor using line commands. Copy, rotate mirror and pattern commands available in Abaqus 6.14 were used to generate complete model.

### 3.3.1.2 Define material for model

It was considered the young's modulus of steel of whole structure's is 208Gpa and density of the steel was considered as 7800kg/m<sup>3</sup> [33].

**3.3.1.3 Meshing the geometry**

Model was meshed with linear beam elements as follows.

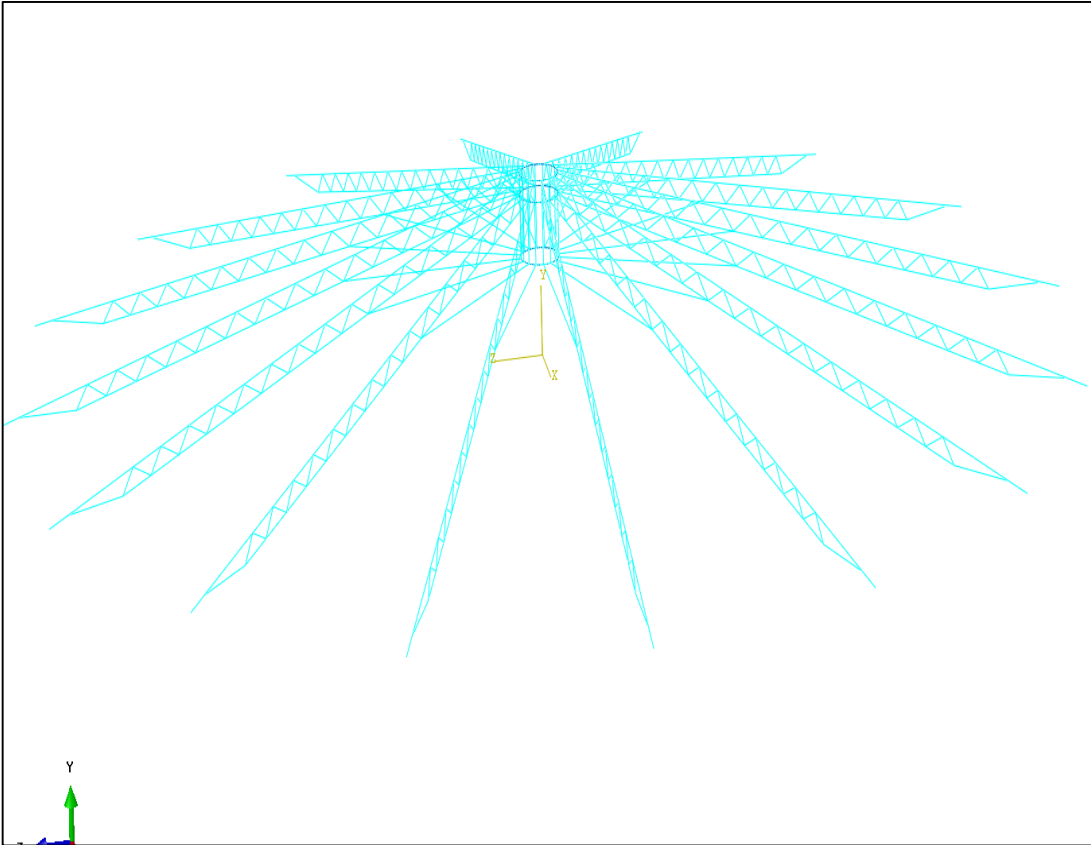

Figure 38: Mesh on the model

### 3.3.1.4 Apply boundary condition to model

There is only one boundary condition on the model. That is edges of the structure should be fixed in vertical direction (y direction), because structure has been kept on the columns without any fixed supports.

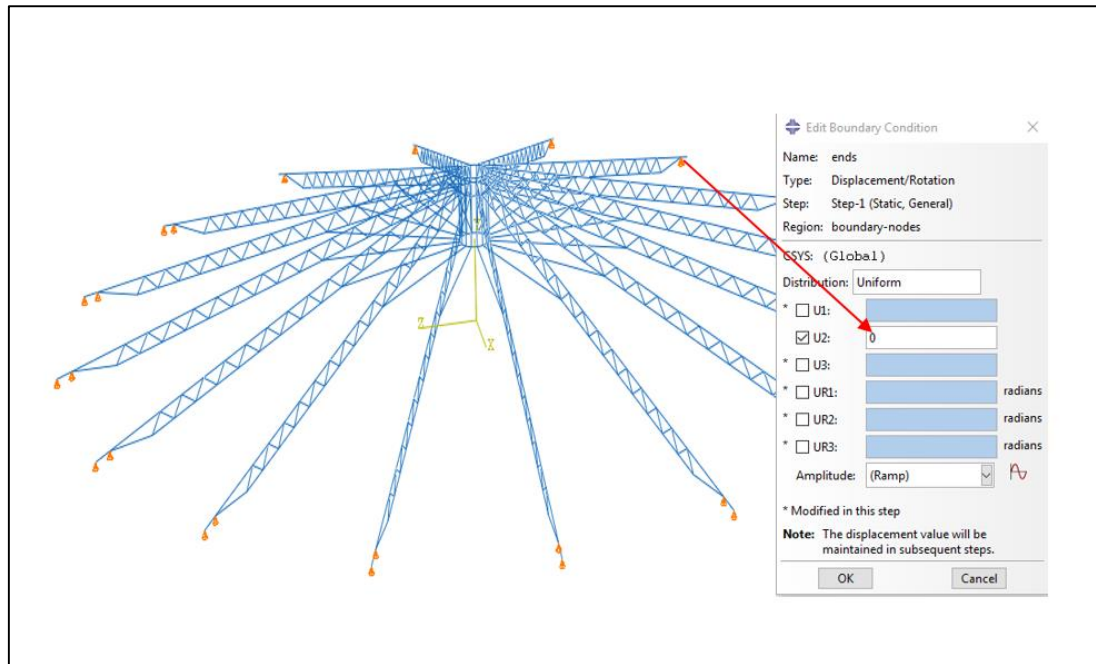

Figure 39: boundary condition on the model

### 3.3.1.5 Apply virtual supports to model

This structure has no enough supports and Abaqus is unable to run the analysis without error message, due to lack of boundary conditions or supports. In the other word, computer needs additional supports to run the analysis. But reaction forces created due to new fixed support should not change the state of the system, or system needs a virtual support. Hence virtual support is given in such a way that, X and Z directions are fixed. Rotational degree of freedom in Y direction also fixed.

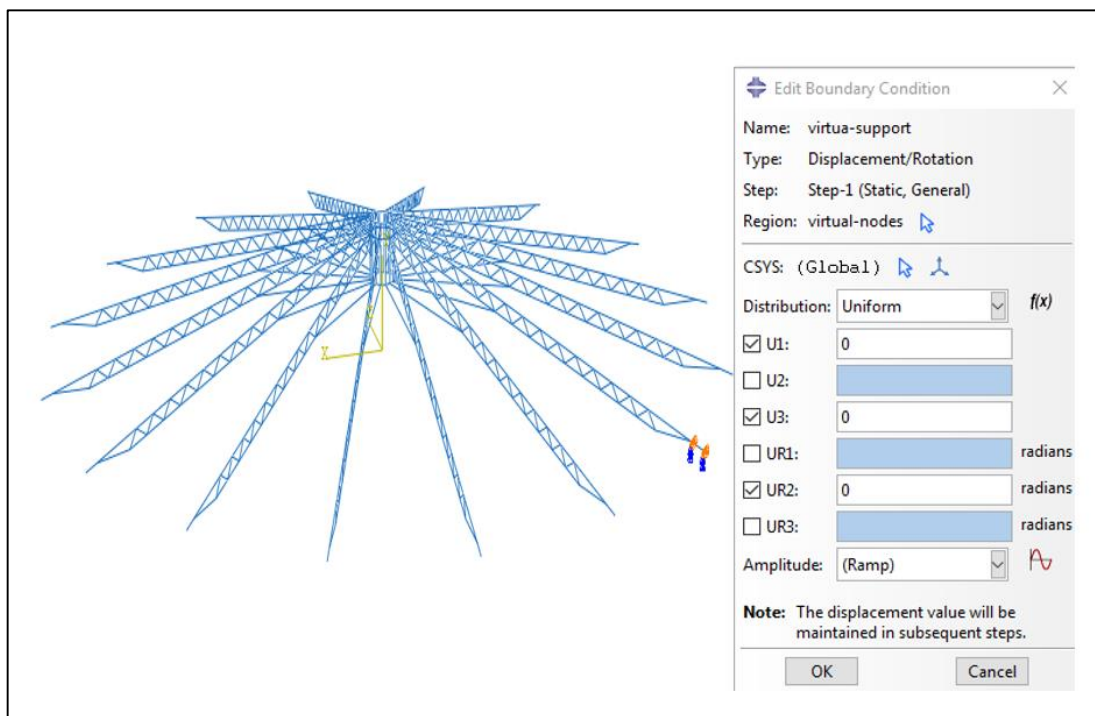

Figure 40: Virtual supports on the roof

Let forces created in X and Z directions due to virtual supports are  $F_x$  and  $F_z$  respectively. Moment around Y axis due to virtual supports is  $M_y$ . By applying Newton's second law in X and Z directions,

$$F_x = 0, F_z = 0 \quad ,$$

Taking moment around y axis,

$$M_y = 0$$

Hence

$$F_x = F_y = M_y = 0$$

Newly added supports do not create any reaction forces or moment on the structure. Therefore original stress/strain in the structure does not change. Hence this supports can be considered as virtual supports.

### 3.3.1.6 Apply the loading to the model

Several vertical loads were applied to nodes in Y direction to the structure for representing electrical fans hang in the roof. Gravity force of the structure was applied at the center of the structure.

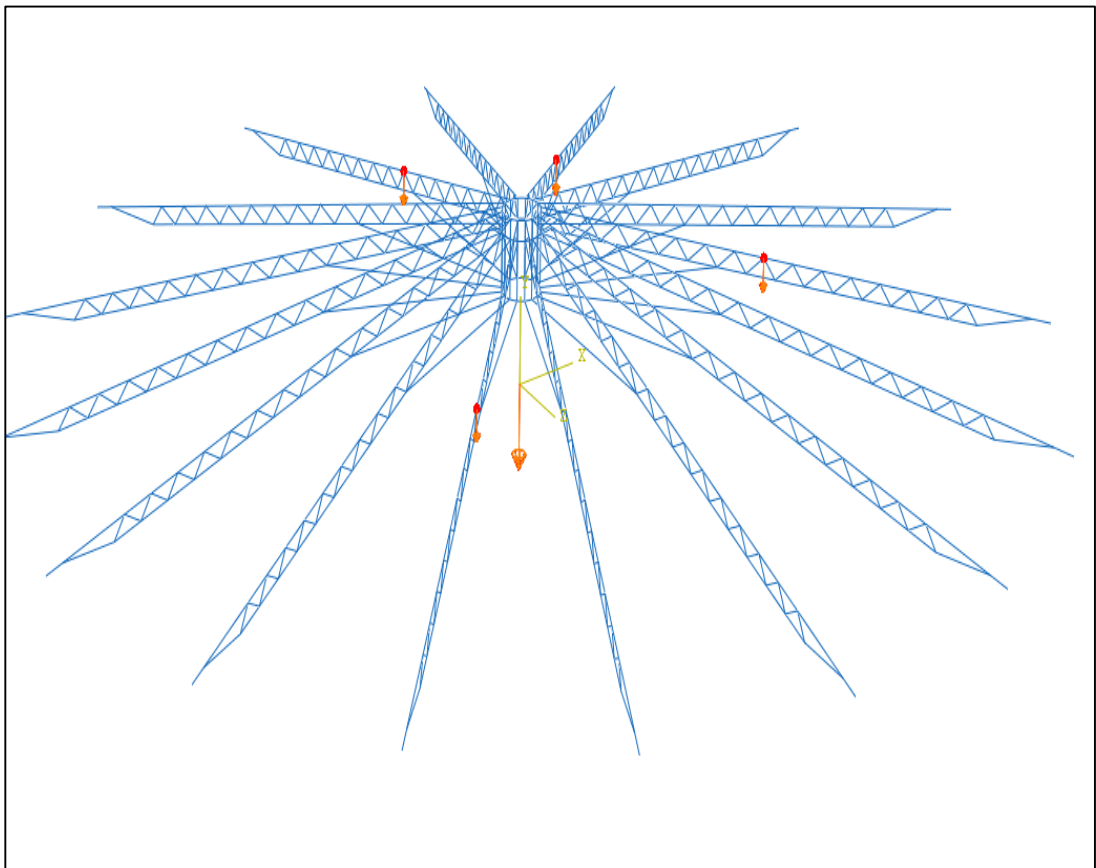

Figure 41: Loading on the structure

### 3.3.1.7 Analyze the model

After applying loading ,boundary conditions and virtual supports structure could be analyzed and stress of each beam was given by software.

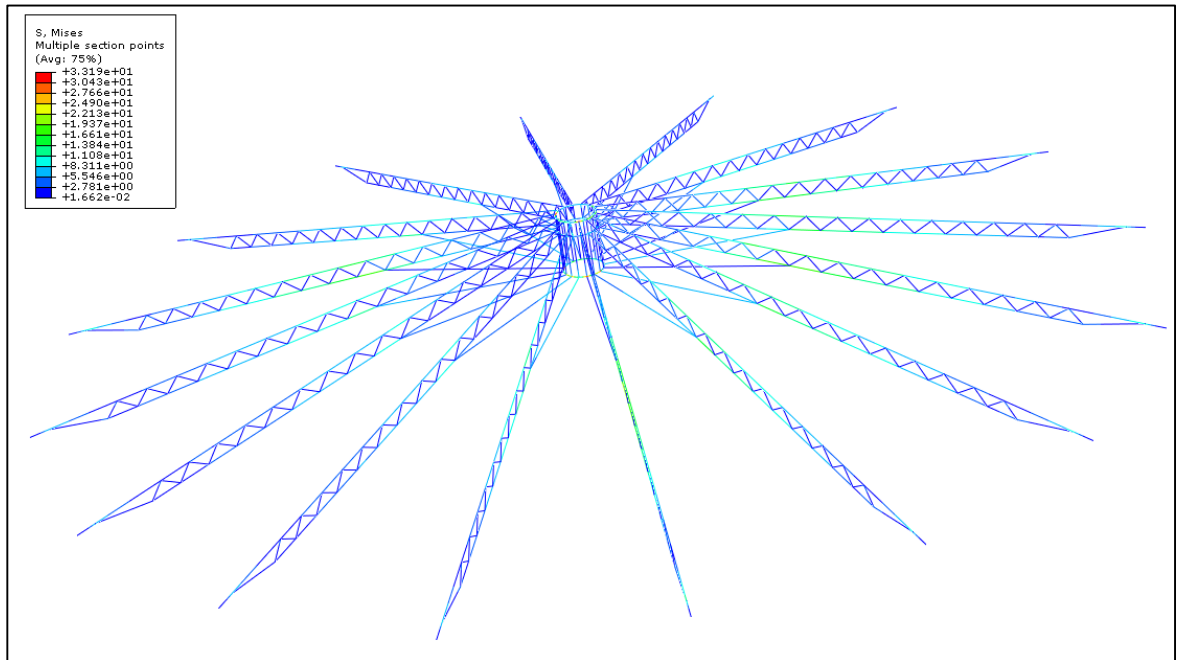

Figure 42: Von misses stress developed on the structure

### 3.3.1.8 Reaction forces generated due to virtual constraint during simulation

virtual constraint creates reaction forces in X and Z direction and moment around Y direction. They are  $F_x$ ,  $F_z$  and  $M_y$ . Respectively. Simulation result shows that values of  $F_x$ ,  $F_z$  and  $M_y$  are very close to zero and these values are 4.8E-8N, -2.7E-9 and -1.9E-5 respectively. Figure 43,44 and 45 show reaction forces and moment values given in the simulation. In the FEA simulation,  $F_x$ ,  $F_z$  and  $M_y$  are not equal to absolute zero, because FEA is a numerical process where round off errors affect to the values of reaction forces and moment.

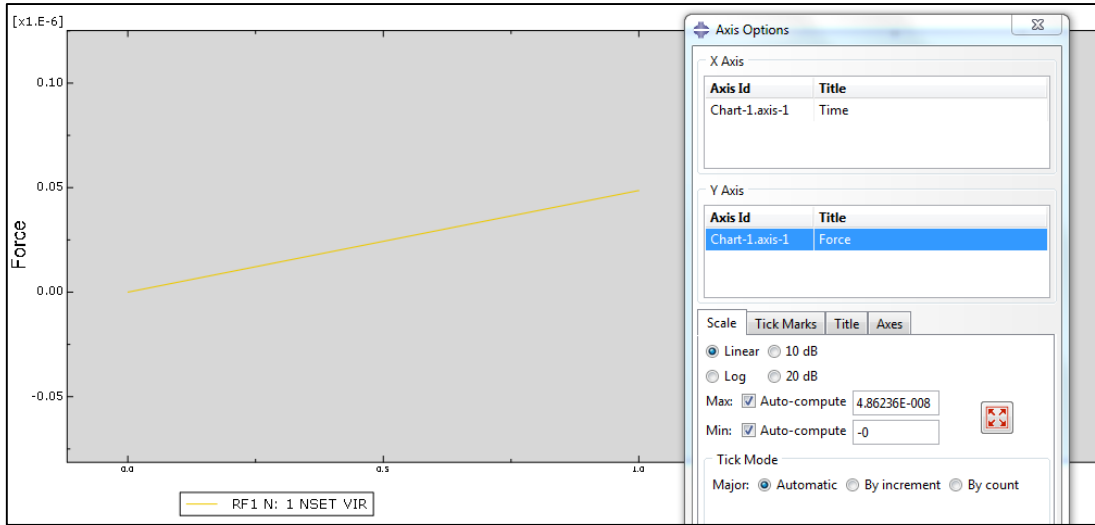

Figure 43: Reaction force in X direction of virtual constraint

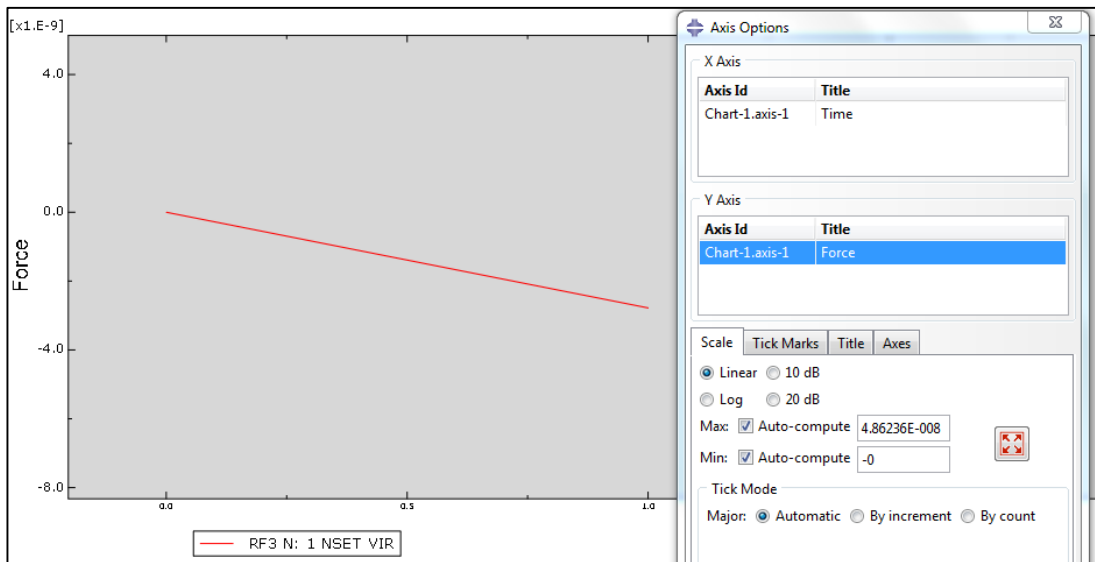

Figure 44: Reaction force in Z direction of virtual constraint

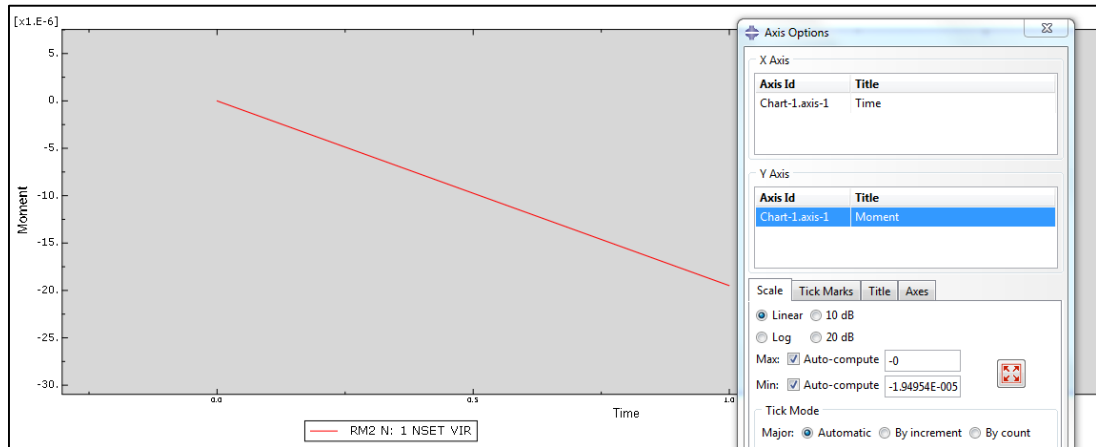

Figure 45: Reaction Moment around Y axis of virtual constraint

### 3.4 Analyzing of a dynamic system with virtual supports

A dynamic system could be considered as a static system if the inertia forces are considered as acting on the reverse direction at the particular (mass) point in the system (fig 37). Then these reversed inertia forces could be considered as ‘free forces’ (non-constrained). Now this system will obviously be a ‘floating type’ system with may be few constraints and free forces including reversed inertia forces.

$I = \delta m \underline{f}$  reversed inertia force

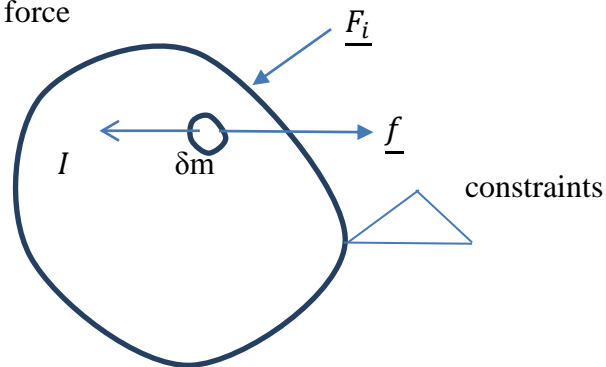

Figure 46: Reversed inertia forces on an object

Now this floating system could be converted to a non-floating system by introducing virtual constraints (supports) and could be analyzed for stress-strain by using the software.

In this case mass of an element will be taken as concentrated at nodes and according to the co-ordinate of the node acceleration of the node will be determined by



dynamics. Then the reversed inertia forces will be considered as the external forces at nodes.

### 3.4.1 Analyzing of a rotating disc with virtual supports

In order to analyze a rotating disc using virtual supports, it was considered a rotational disc as shown below. Its dimensions and other parameters are given below[32].

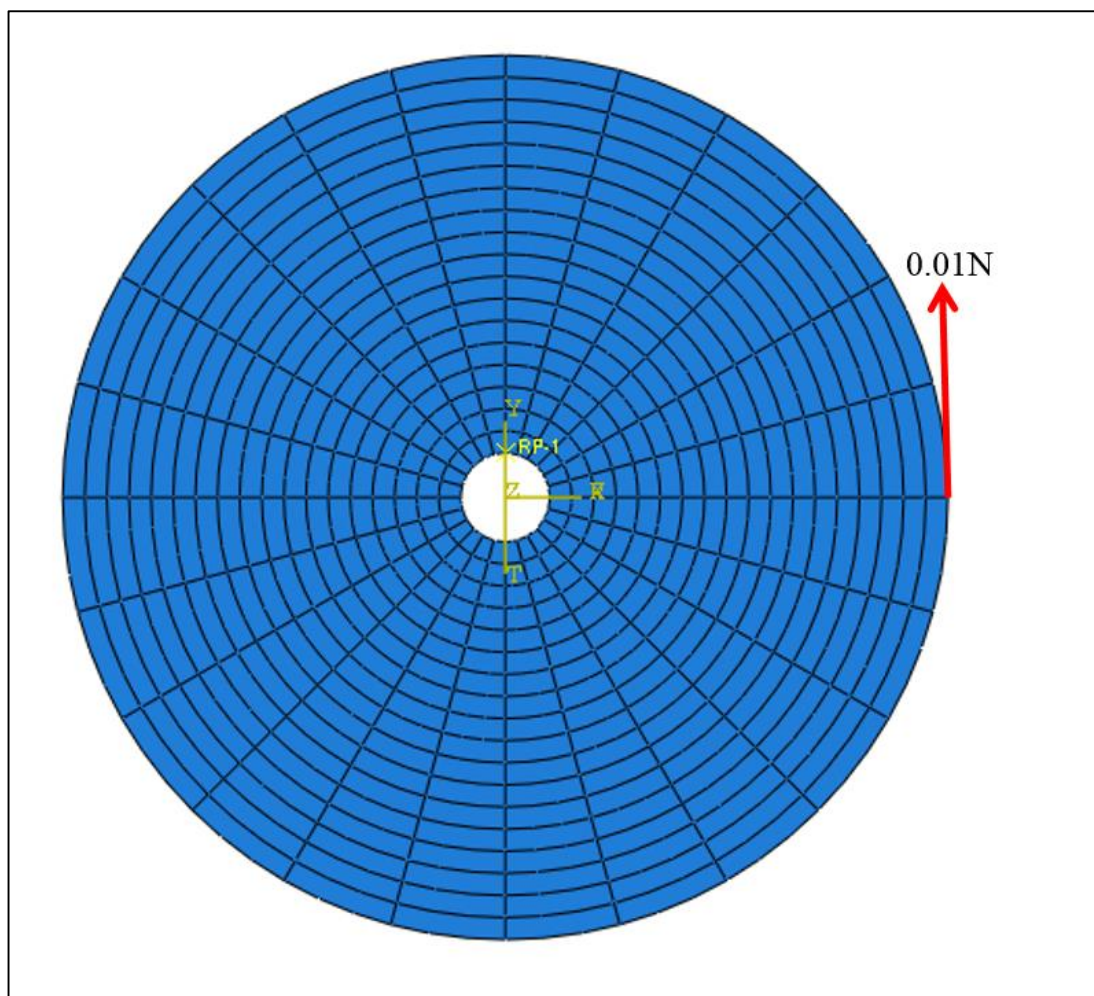

Figure 47: Force on a rotating disc

Table 1:Parameters of the rotating disc

inner diameter ( $r_1$ )	0.005m
Outer diameter ( $r_2$ )	0.05m
Thickness (t)	0.005m
Density (d)	7800Kg/m <sup>3</sup>

### 3.4.1.1 Calculation of centrifugal force and tangential force

This disc is subjected to 0.01N external force (F) as shown by the above figure (47). Disc angular velocity ( $\omega$ ) is taken as 2 rad/s. Hence angular acceleration of the disc can be calculated as following.

$$\begin{aligned} \text{Mass of the disc (m)} &= \pi(r_2^2 - r_1^2) \cdot t \cdot d \\ &= \frac{22}{7} \{ (0.05^2) - (0.005^2) \} \cdot 0.005 \cdot 7800 \\ &= 0.30 \text{Kg} \end{aligned}$$

$$\begin{aligned} \text{Second moment of Inertia of the disc (I)} &= \frac{1}{2} \cdot m \cdot (r_2^2 + r_1^2) \\ &= 0.5 \cdot 0.3 \cdot \{ (0.05^2) + (0.005^2) \} \\ &= 0.00038 \text{Kgm}^2 \end{aligned}$$

$$\begin{aligned} \text{Torque on the disc } (\tau) &= F \cdot r_2 \\ &= 0.01 \cdot 0.05 \\ &= 0.0005 \text{Nm} \end{aligned}$$

$$\begin{aligned} \text{Angular acceleration of the disc } (\alpha) &= \tau / I \\ &= 0.0005 \text{Nm} / 0.00038 \text{Kgm}^2 \\ &= 1.306 \text{rad/S} \end{aligned}$$

Geometry was divided to small segments of 30 degree in circumference directions and divided to 9 segments along radial direction. Their center of gravities were

grouped as A1 to A9. Figure 48 shows all the center of gravities of first segments along radial direction and their center of gravities are A1 .

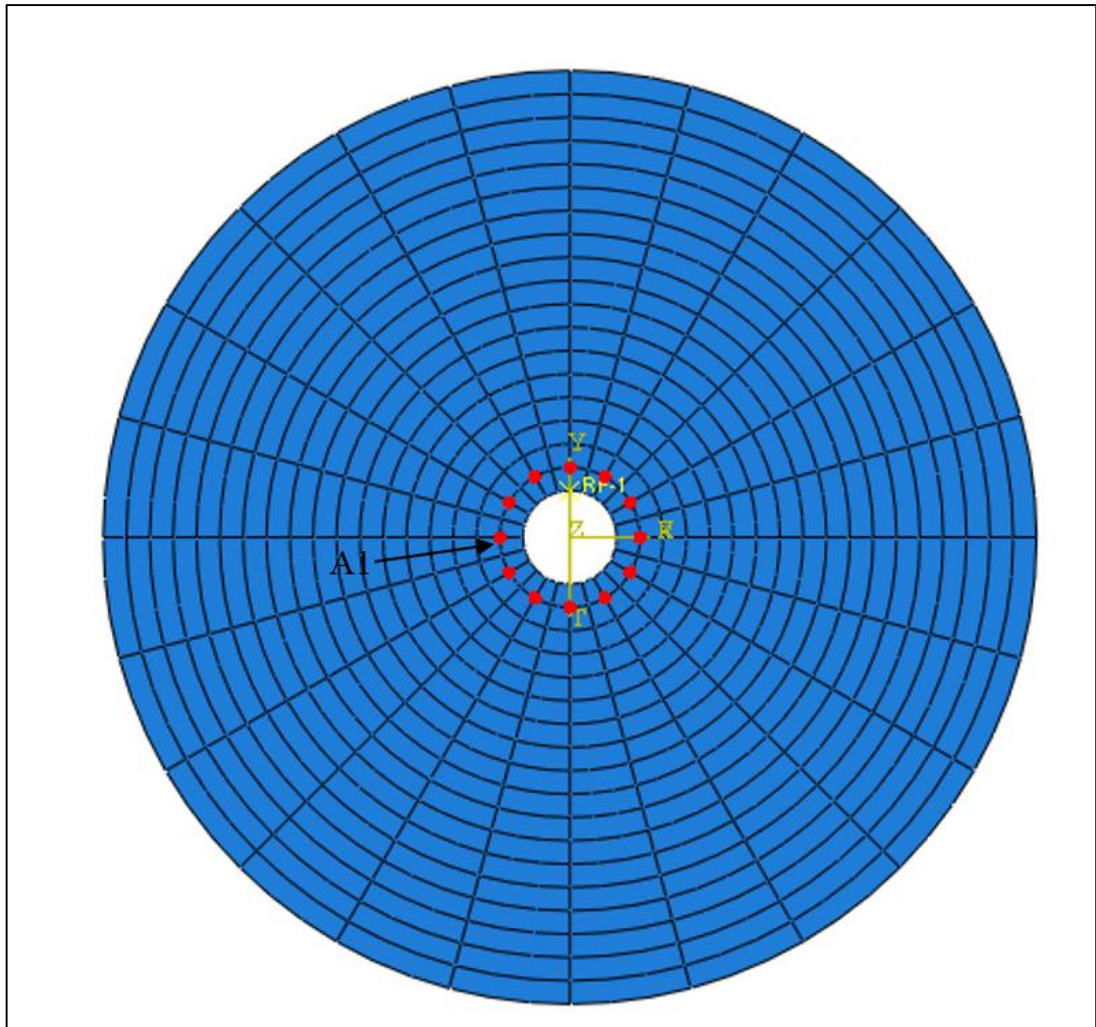

Figure 48: Center of gravities of first segment

Inertia forces applied on each group are tabulated by below table.

Table 2: Calculation of inertia forces

Group	r1	r2	Area= 0.5(r2 <sup>2</sup> -r1 <sup>2</sup> )*angle	dm=mass	R=r1+r2/2	Fr=dm*R*w <sup>2</sup>	Ft=dm*R*alpha
A1	0.005	0.01	1.9635E-05	0.00076576	0.0075	2.29729E-05	7.50075E-06
A2	0.01	0.015	3.27249E-05	0.00127627	0.0125	6.38136E-05	2.08354E-05
A3	0.015	0.02	4.58149E-05	0.00178678	0.0175	0.000125075	4.08374E-05
A4	0.02	0.025	5.89049E-05	0.00229729	0.0225	0.000206756	6.75068E-05
A5	0.025	0.03	7.19948E-05	0.0028078	0.0275	0.000308858	0.000100843
A6	0.03	0.035	8.50848E-05	0.00331831	0.0325	0.00043138	0.000140847
A7	0.035	0.04	9.81748E-05	0.00382882	0.0375	0.000574322	0.000187519
A8	0.04	0.045	0.000111265	0.00433932	0.0425	0.000737685	0.000240857
A9	0.045	0.05	0.000124355	0.00484983	0.0475	0.000921468	0.000300863

$r_1$ - first radius of segment

$r_2$ - second radius of segment

$F_r$  -Centrifugal force

$F_t$ -tangential force

### 3.4.1.2 Force applied on the FEA model

In the FEA model, nodes were generated at the center of the each small segments' center and  $F_r$  and  $F_t$  forces were applied as nodal forces in radial and tangential direction respectively.

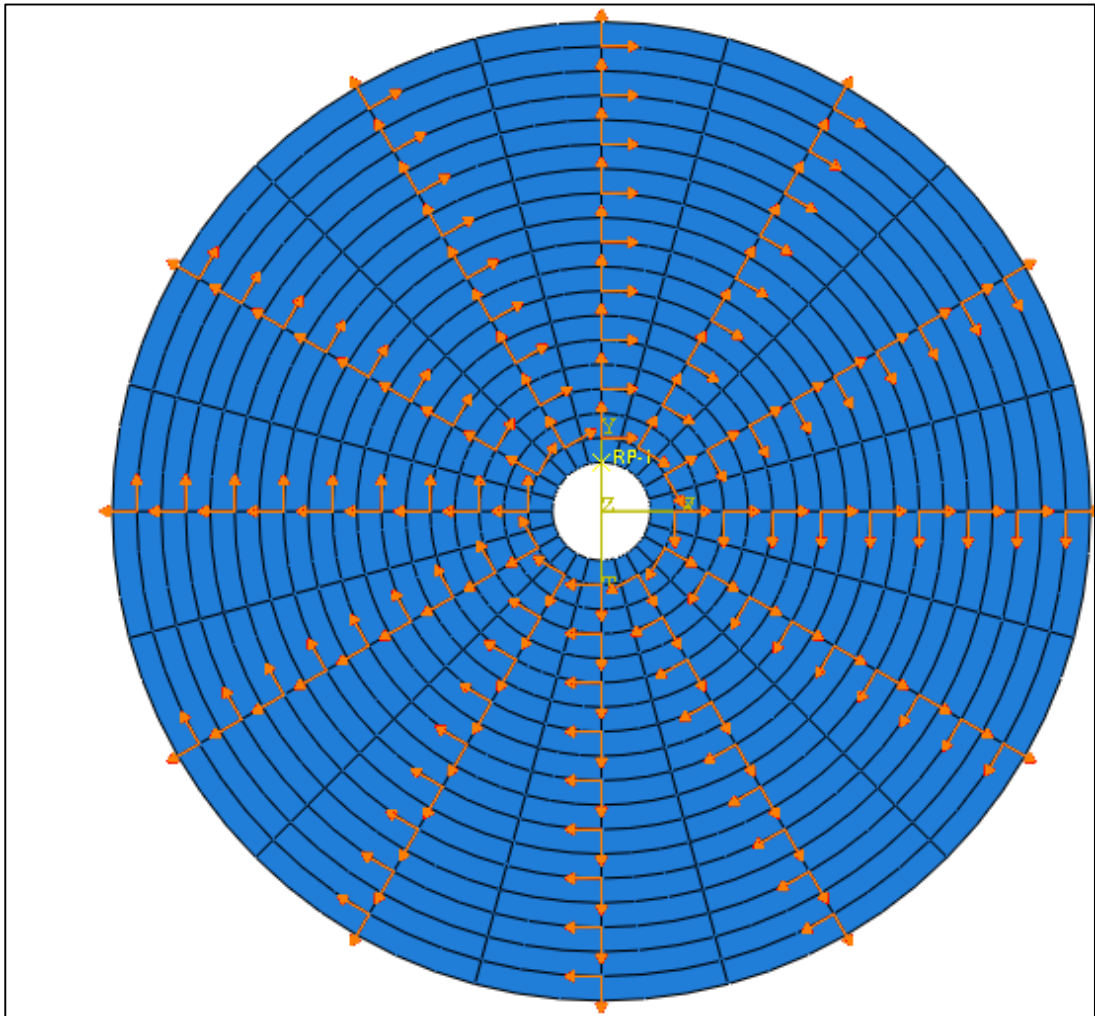

Figure 49: Reverse inertia forces on the disc

### 3.4.1.3 Boundary condition applied on the model

In the actual situation, the disc is rotated around a shaft. It can be considered as one point of the inner diameter of the disc is touched with the shaft's outer diameter. In order to simulate this condition, boundary condition is applied in such a way that, Y direction of the node is given fixed supports as shown figure 50.

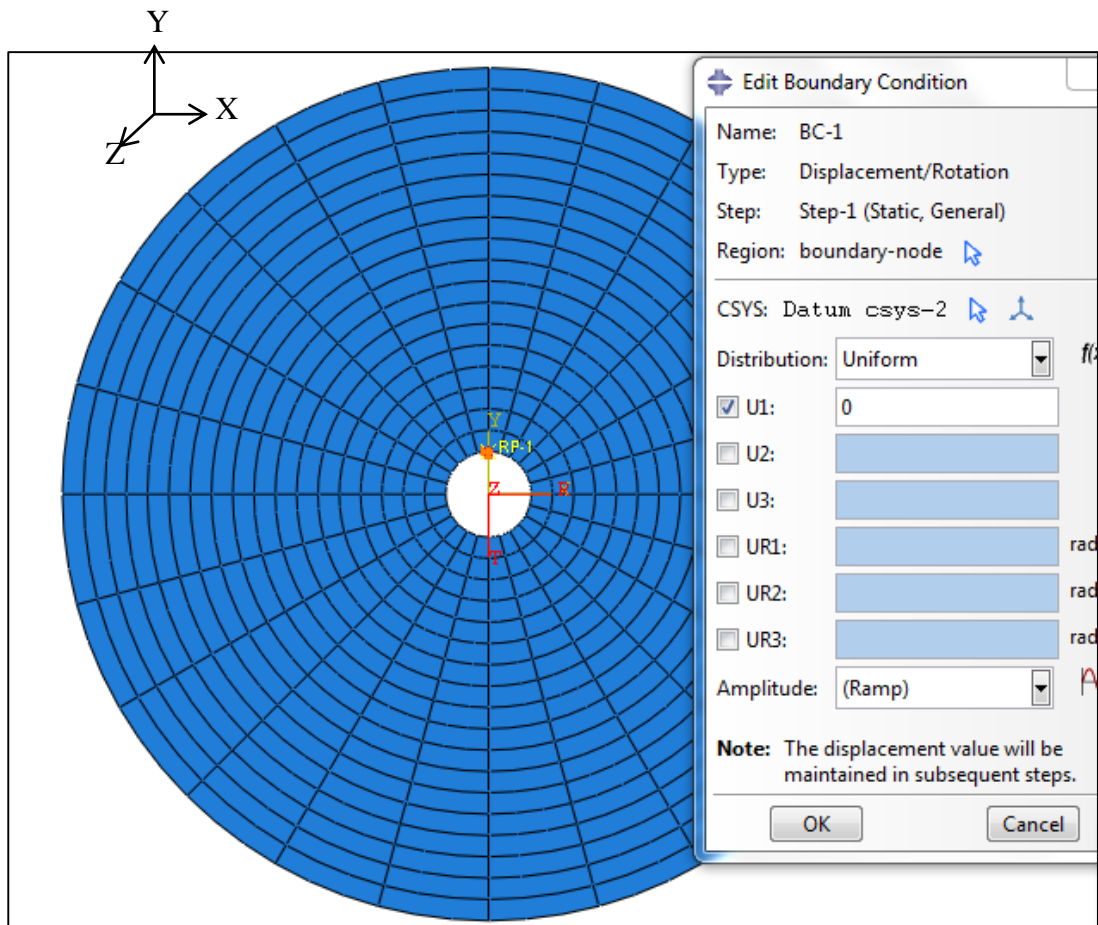

Figure 50: Boundary condition on the rotating disc



### 3.4.1.4 Applied virtual support to the model

Additionally X and Z directions are given fix boundary conditions to the same node in order to act as virtual supports. Moment about Z axis is also locked as figure 51.

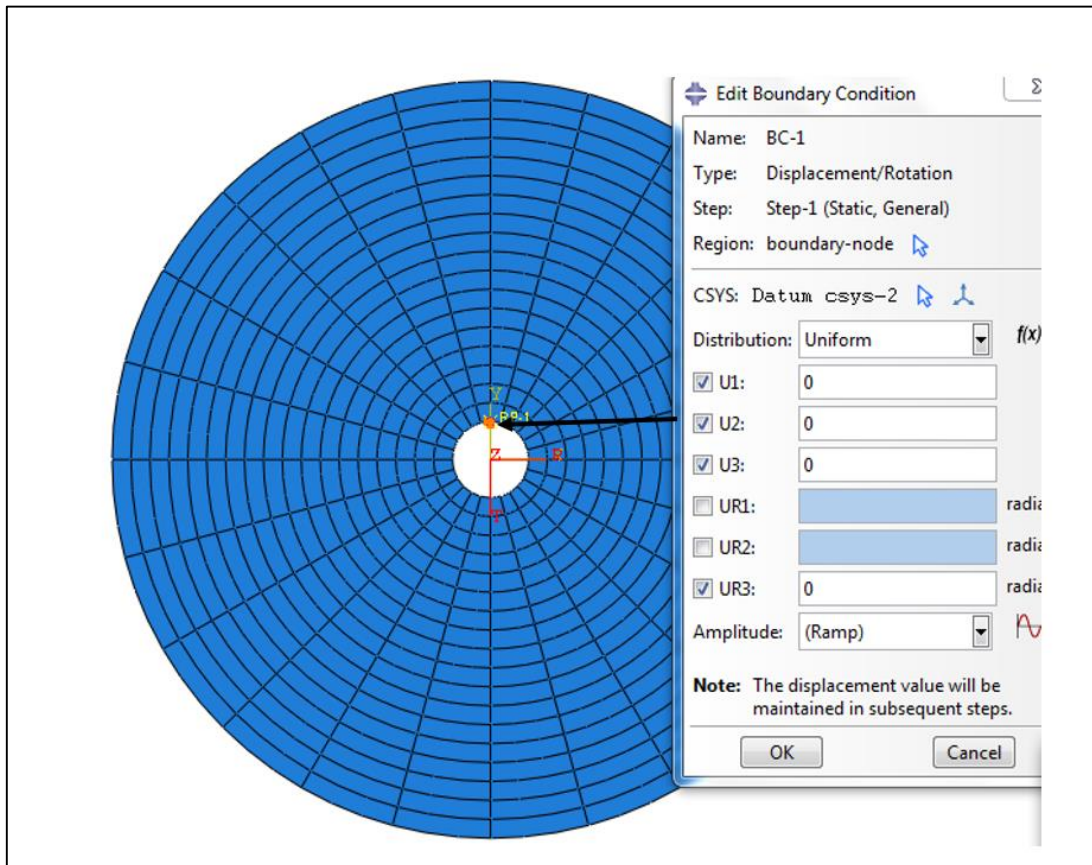

Figure 51: virtual supports to the disc

Due to applied virtual supports reaction forces generated in X and Z directions are  $F_x$  and  $F_z$ . Moment created around Z axis is  $M_z$ .

By apply Newton's second law to disc

$F_x = 0$  ; Since externally applied load is balance by inertia forces according to D'Alembert principle

$F_z = 0$  ; There are no any external forces in Z directions

$M_z = 0$  ; There are no any external moments around Z axis

### 3.4.1.5 Analyzed the model in Abaqus

After applying virtual supports, disc can be analyzed in Abaqus software. Von misses stress contour of rotating disc is given below.

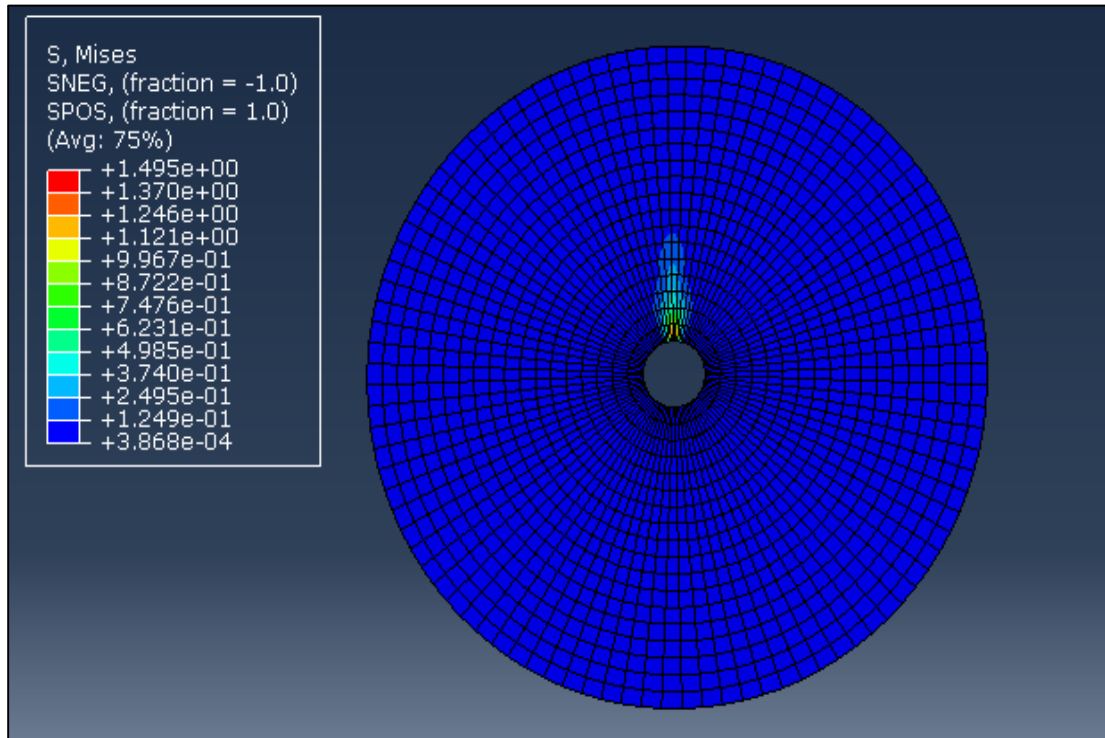

Figure 52: Von misses stress of rotating disc

### 3.4.1.6 Reaction forces generated in virtual constraint

After analysis of Abaqus, reaction forces in X and Z direction of virtual constraint and reaction moment around Z axis can be visualized as a graph as follows. According to figure 53, reaction force  $F_x = -5E - 15N$  and it is very much close to zero. According to figure 54, reaction force  $F_z = 0$ . As figure 55 shows, moment around Z axis  $M_z = 0.003Nm$  and it can be considered as close to zero. In the FEA simulation  $F_x$  and  $M_z$  are not equal to absolute zero, but they are very close to zero because when calculating reverse inertia forces, decimal fraction after 3 digits were left and it affects to values of reaction forces generated at virtual constraint.



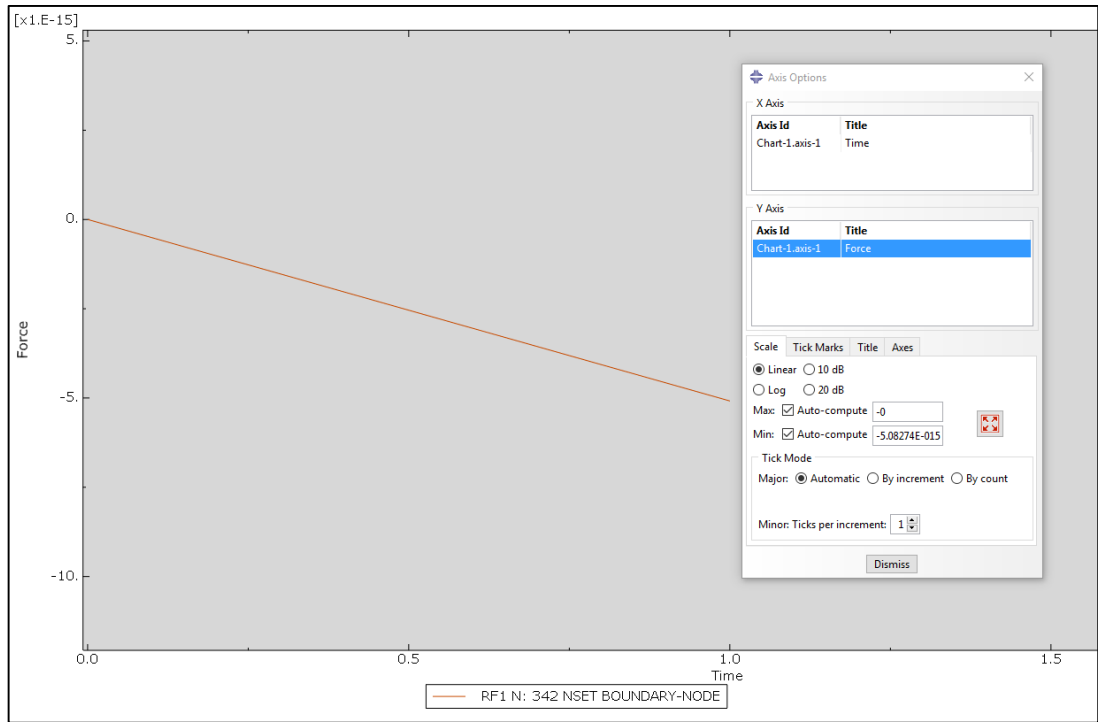

Figure 53: Reaction force in X direction of virtual constraint

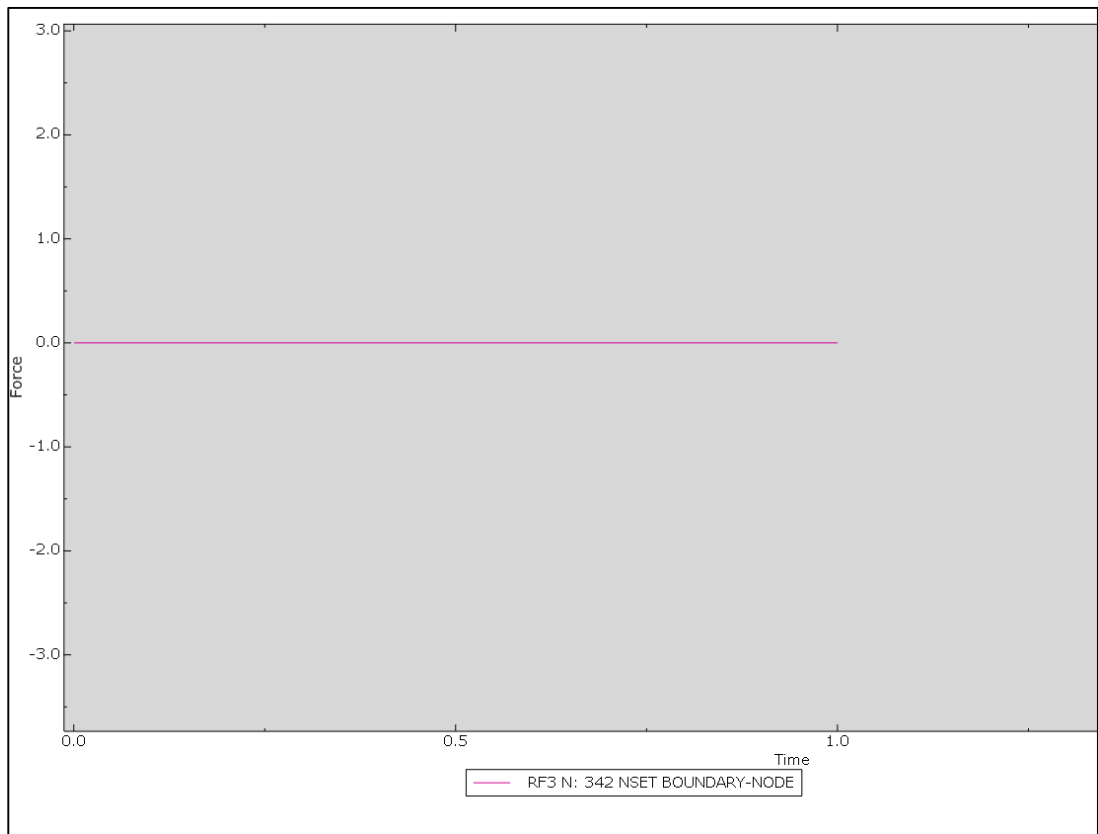

Figure 54: Reaction force in Z direction of virtual constraint

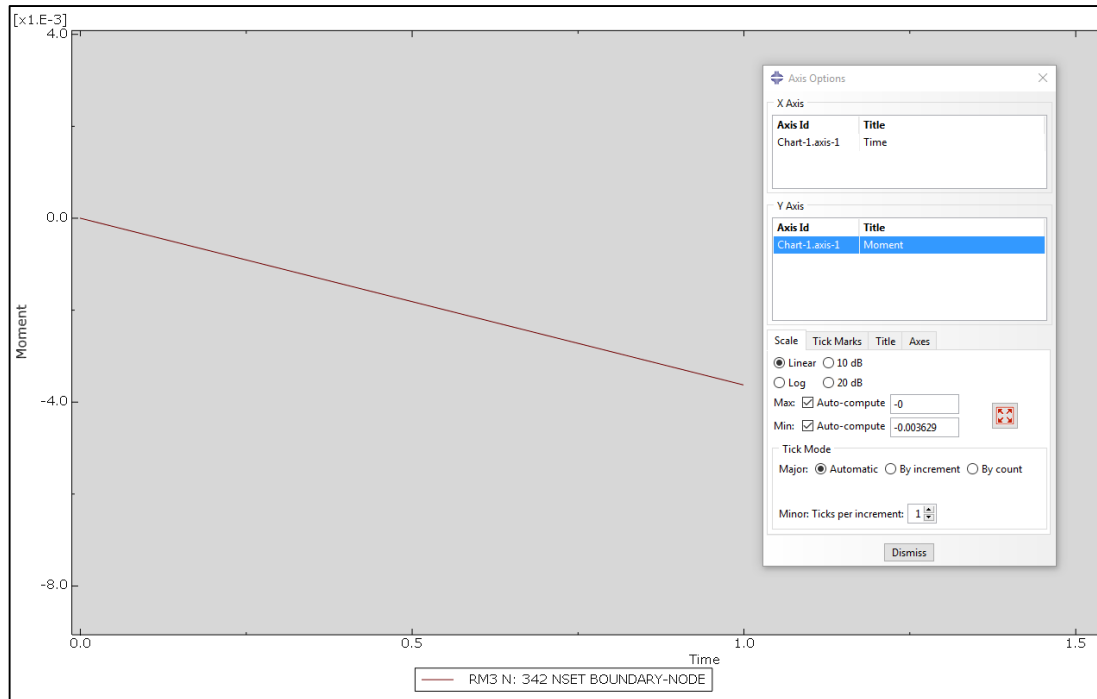

Figure 55: Moment around in Z axis of virtual constraint

### 3.4.2 Stress-strain analysis of a wind blade

When a 2 segments wind blade rotates, free forces (inertia forces) and external forces can be indicated as fig 54.

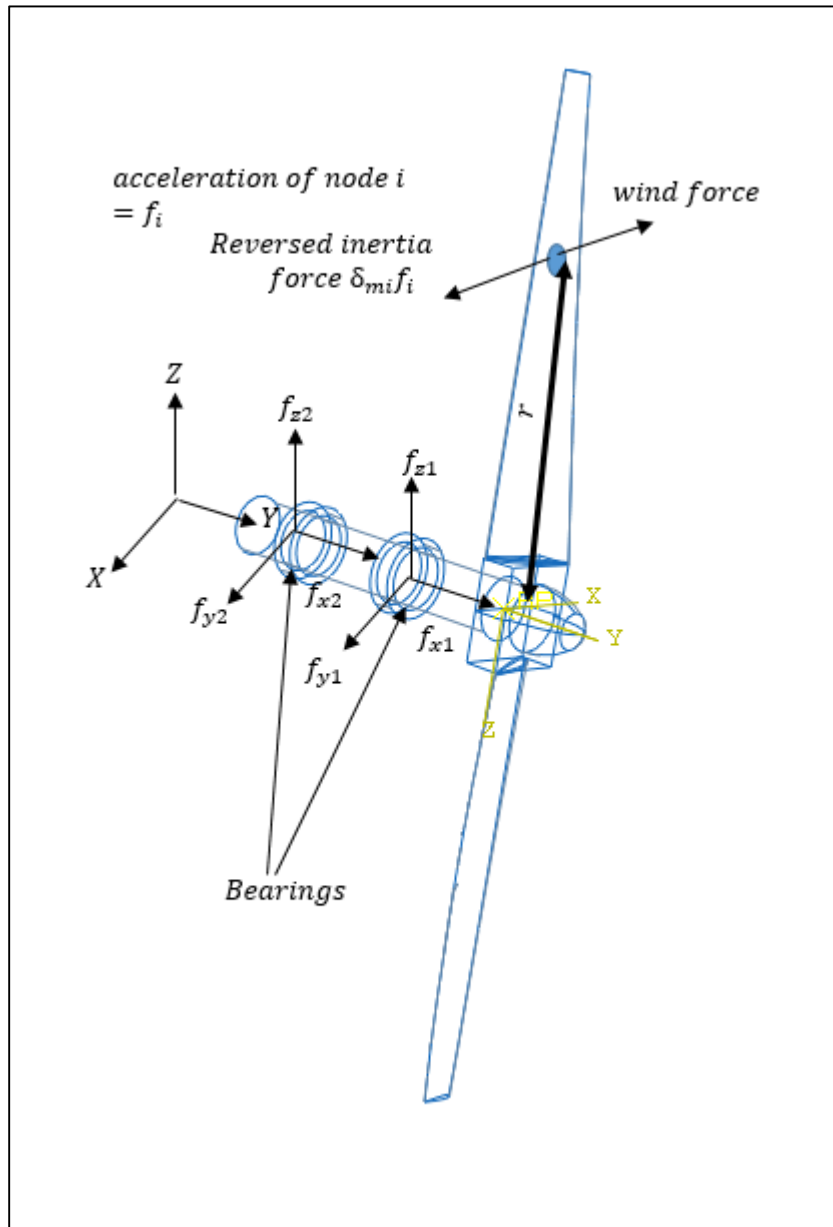

Figure 56:kinematics of wind blade

### 3.4.2.1 Determine $f_i$ from dynamics

By kinematics acceleration in Y and Z directions  $\ddot{y}$  and  $\ddot{z}$  can be determined as following equations.

$$\ddot{y} = -r(-\ddot{\alpha}\sin\alpha - \dot{\alpha}^2\cos\alpha)$$

$$\ddot{z} = \ddot{\alpha}r\cos\alpha - \dot{\alpha}^2r\sin\alpha$$

$\ddot{\alpha}$ -rotational acceleration of the Wind blade

#### 3.4.2.1.1 Calculate the $\ddot{\alpha}$

$\ddot{\alpha}$  can be found from relationship given that  $T = I\ddot{\alpha}$ . I is the polar moment of inertia of the wind blade. T is the torque generated from wind force exerted on the wind blade. T can be found by a FE analysis.

In FE analysis, following constraints are given to rotating shaft in order to find torque T. under constraint, global X,Y,Z directions are constrained the outside surface of the bearings. Rotational degree of freedom in the shaft is fixed around Y axis (Figure 57).

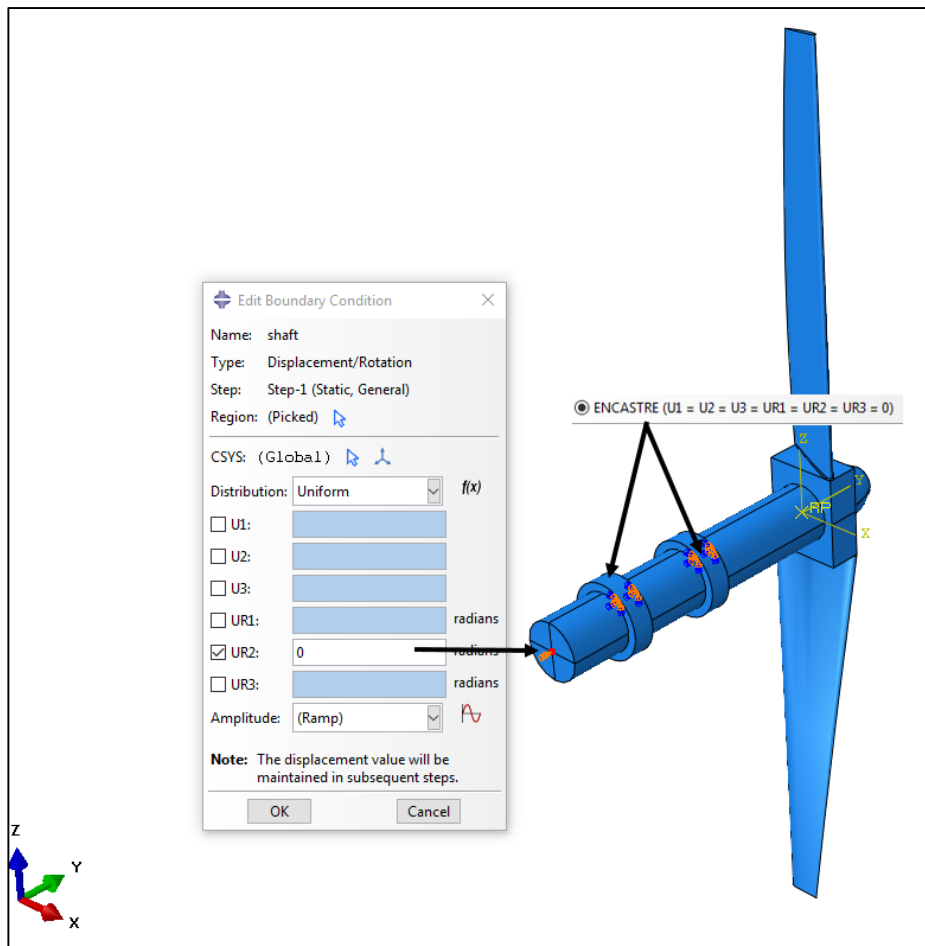

Figure 57: Constraint on wind blade

Drag forces  $dF_v$  and  $dF_u$  due to wind forces on the wind blade are given by the following relationship [34]. Dimensions attached to relationships are shown in figure 58.

$$dF_v = 1/2\rho lW^2 dr(C_l \cos\phi + C_d \sin\phi)$$

$$dF_u = 1/2\rho lW^2 dr(C_l \sin\phi + C_d \cos\phi)$$

$P$ = density of air

$W$ = resultant velocity of wind speed and blade linear speed

$\phi = \tan^{-1}(\text{wind speed}/\text{blade linear speed})$

$C_d$  are co-efficient from NACA 4415 graph.

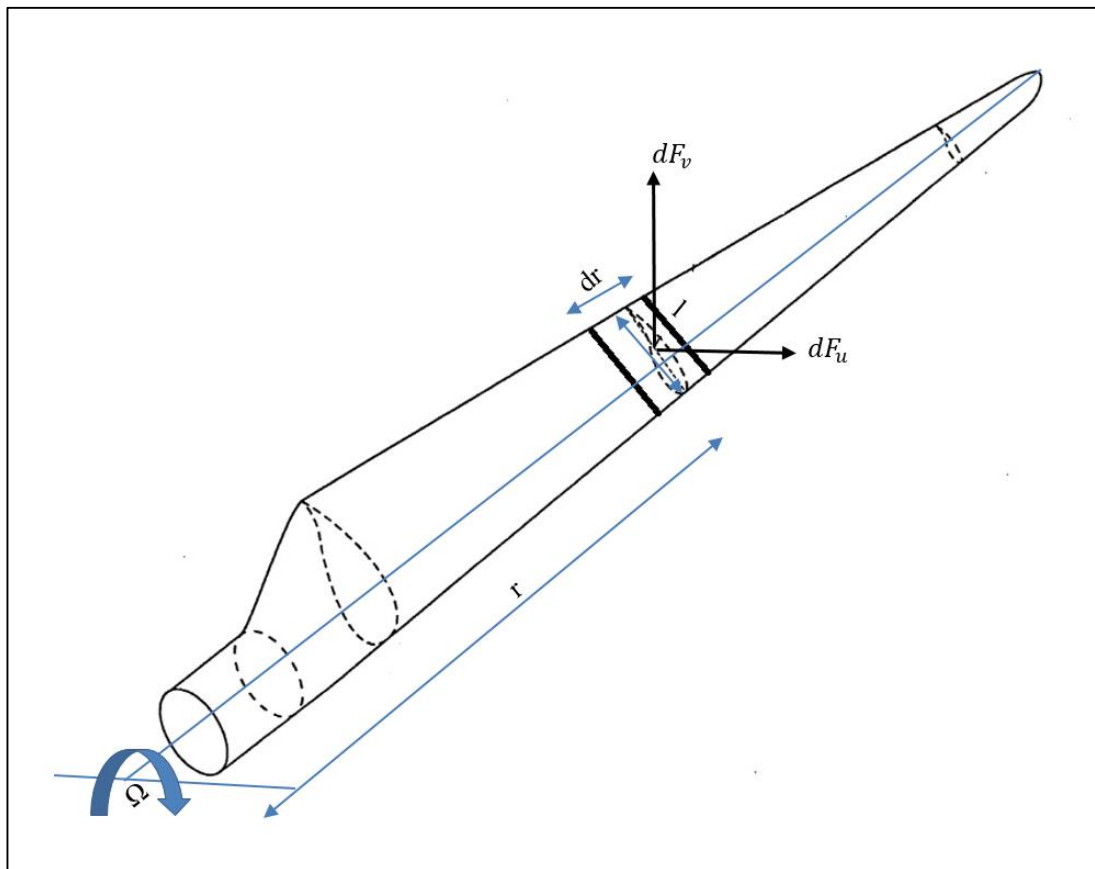

Figure 58: Wind force on the FEA model

Drag forces  $dF_v$  and  $dF_u$  were calculated to several segments of the wind blades and they are applied as figure 59.

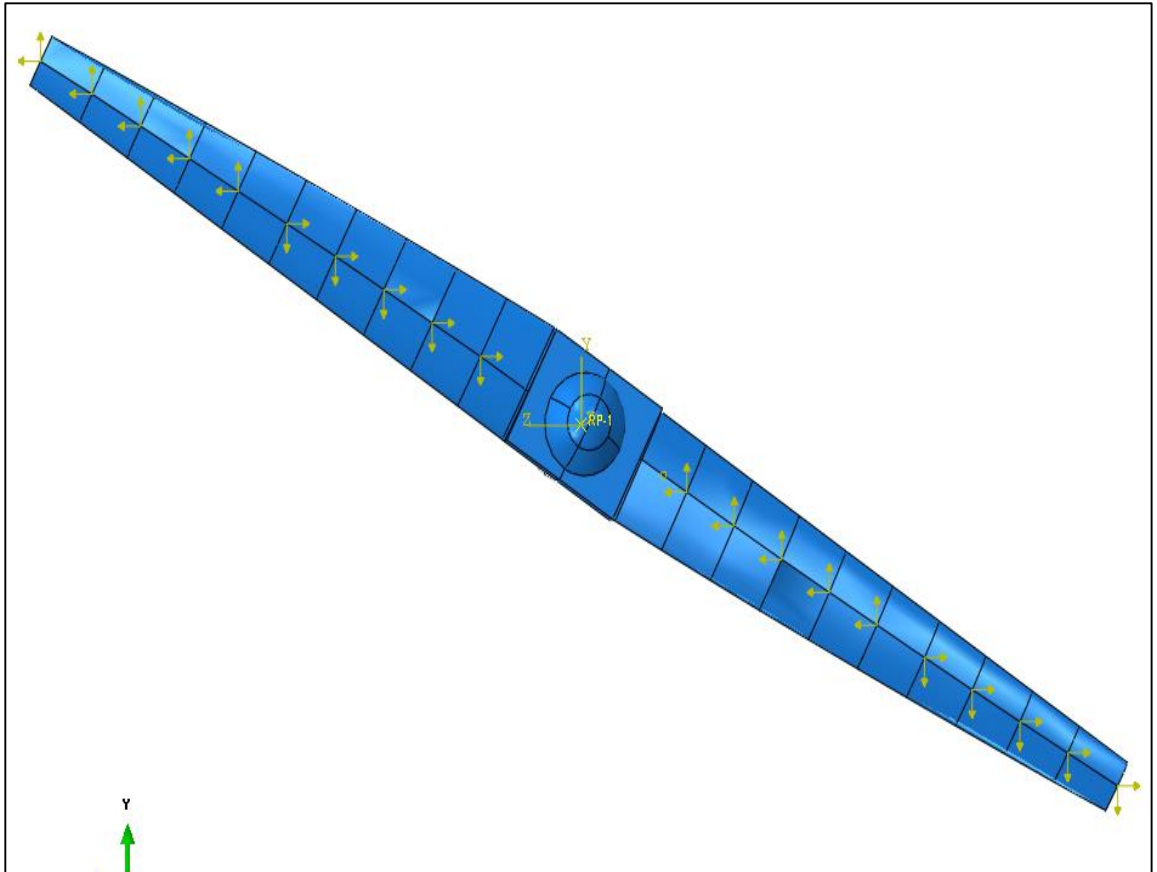

Figure 59: drag forces on the wind blade

From static analysis, torque  $T$ , generated in the constraint point can be calculated.  $T$  is 19Nm. Then

$$\ddot{\alpha} = T/I$$

$I = 3.488 \text{kgm}^2$ , can be found by CAD interface

$$\ddot{\alpha} = 5.44 \text{ rad/s}^2,$$

### 3.4.2.2 Apply reversed inertia forces at the nodes

Abaqus creates an input file for the model and it contains the nodal co-ordinates. it can be written command to get each element mass ( $\delta_m$ ) as individual element output to input file also. From section 3.4.2.1,  $\ddot{y}$  and  $\ddot{z}$  can be calculated for all the nodes and it can be used to find  $\delta_m \ddot{y}$  and  $\delta_m \ddot{z}$  of each nodes. When calculate  $\ddot{y}$  and  $\ddot{z}$  initial values for  $\alpha$  is taken in arbitrary manner.

input file can be edited in such a way that , reversed inertia forces are applied in y and Z direction to all the nodes of the model (Figure 60).

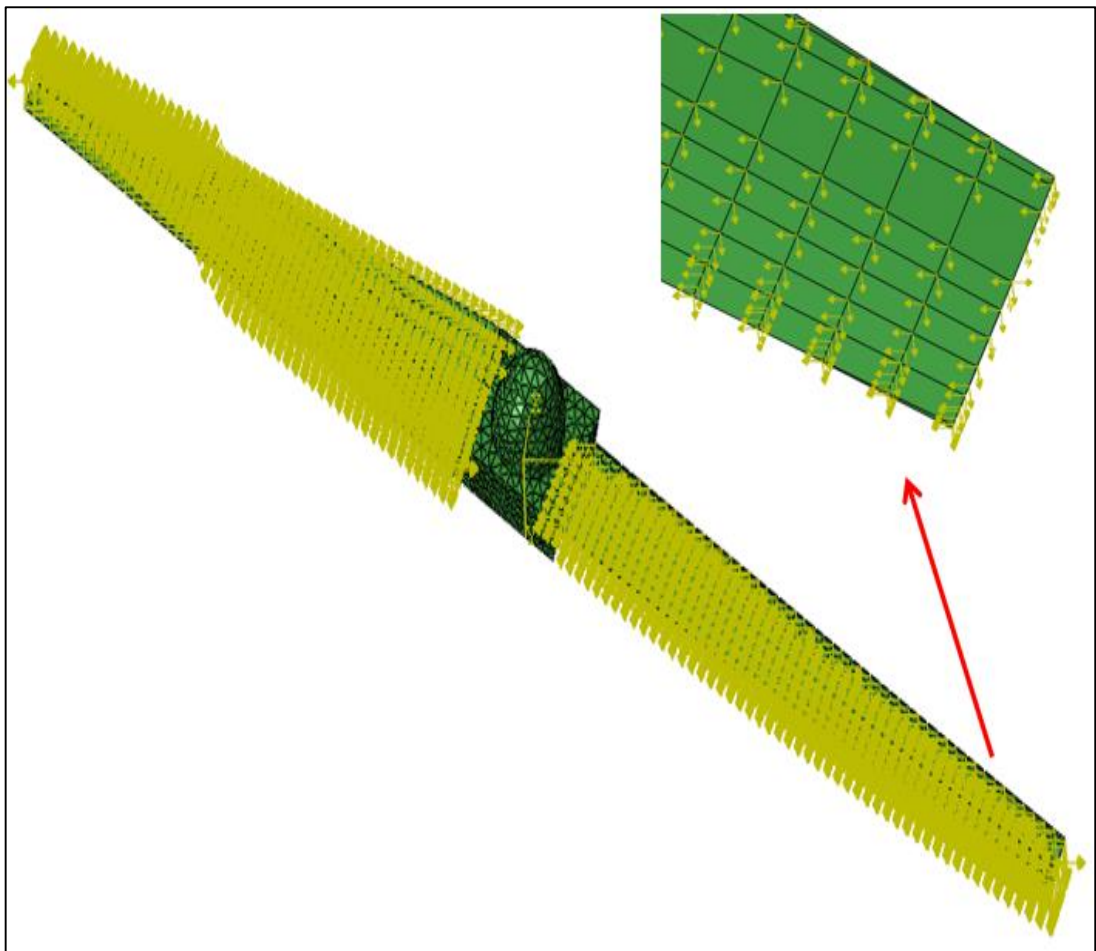

Figure 60: reversed inertia forces on the model

### 3.4.2.3 Apply virtual constraints

After inertia forces are applied, model acts as a semi-floating system. Because wind blade can be rotated around y axis by applying an external torque around y axis. Hence virtual constraint is given to model as torque is created around y axis (figure 61)

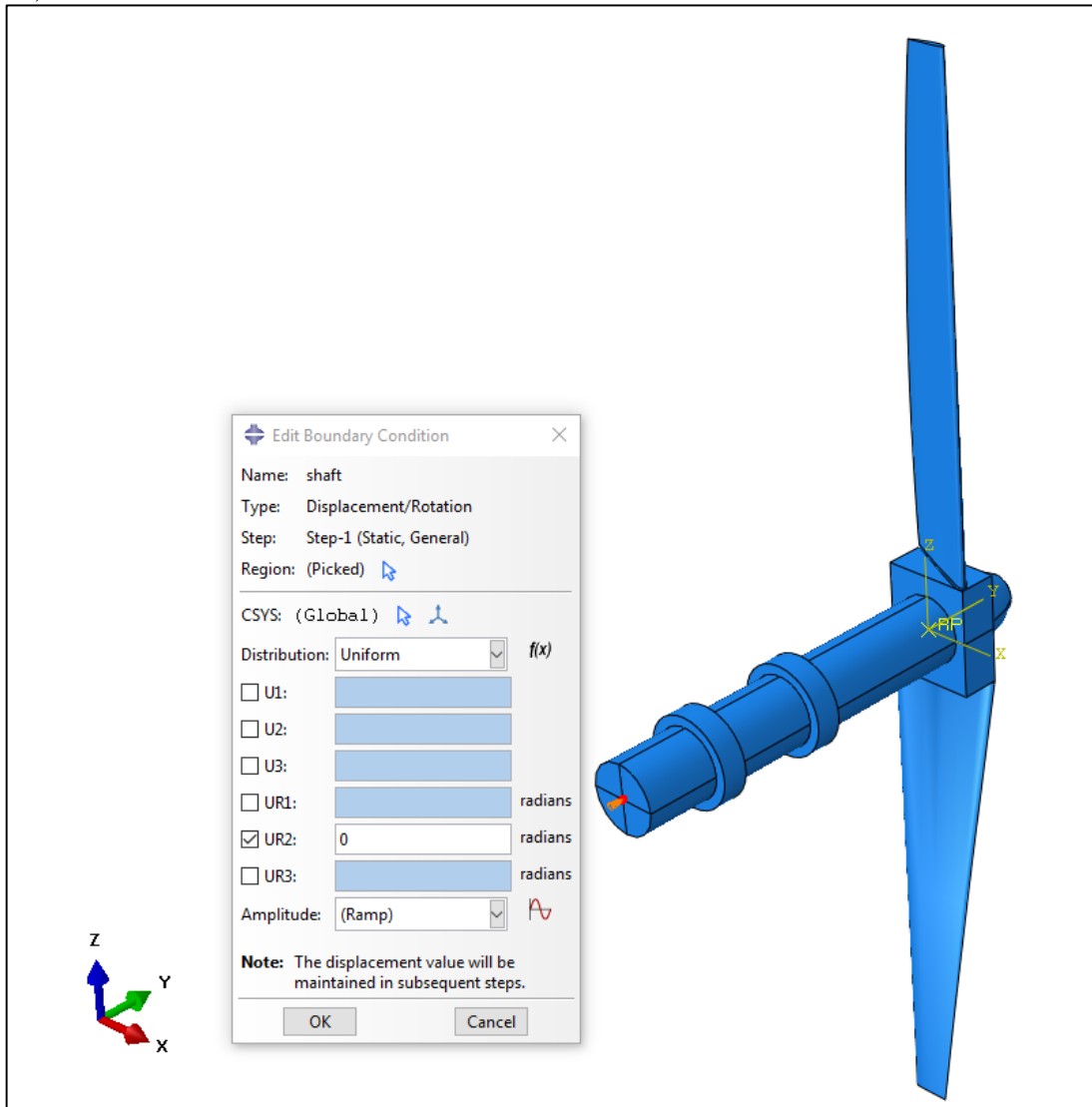

Figure 61: Virtual support on the model

Due to virtual constraints, external moment created around axis y is  $M_y$ .

By taking the moment about y axis  $M_y = 0$ , because moment created from wind forces is balanced by the moment created from the reverse inertia forces.



### 3.4.2.4 Analysis the system

Aluminum properties are given as the material property of the wind blade. By performing static linear analysis, stress and strain generated on the wind blade can be found.

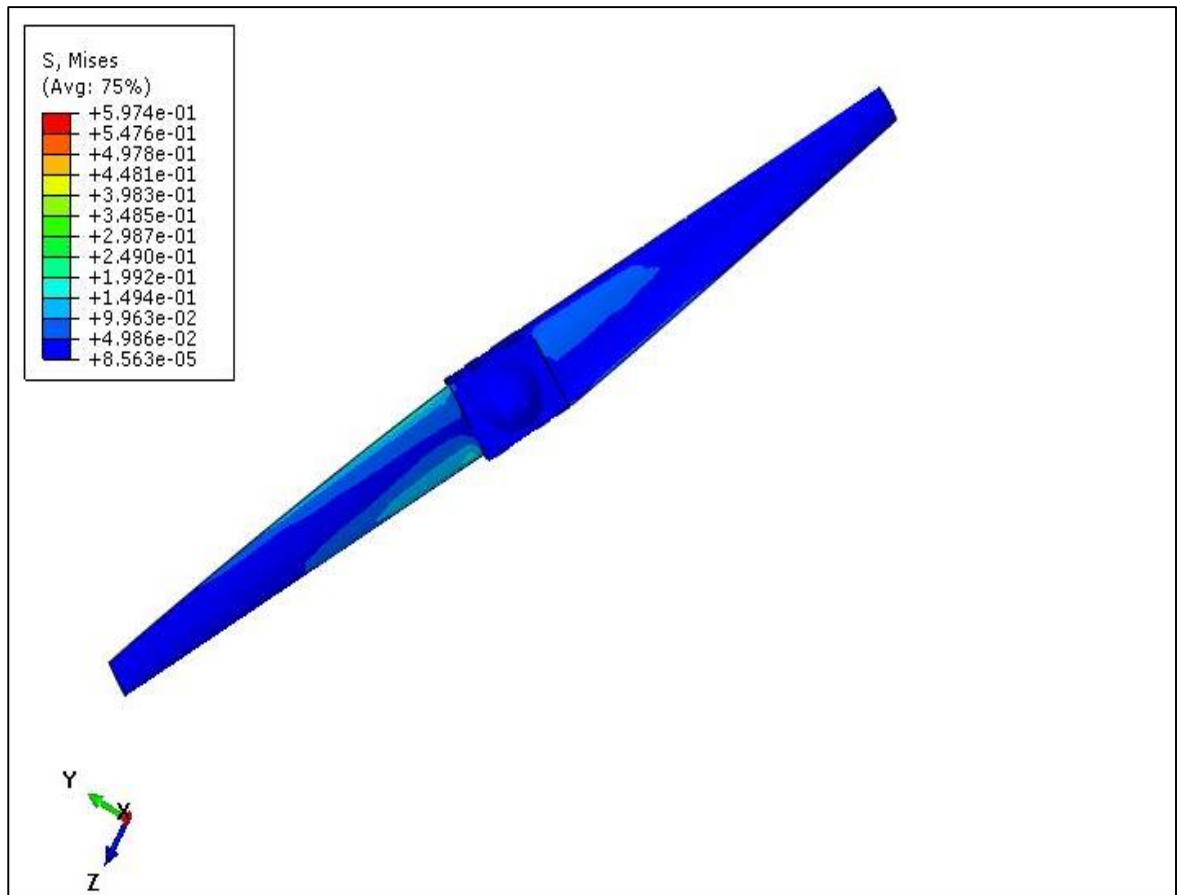

Figure 62: Stress analysis of wind blade at static mode

### 3.4.2.5 Reaction Moment around Y axis of Virtual support

Reaction moment  $M_y$  is given as history output and which is very close to zero (-0.01Nm).  $M_y$  does not become absolutely zero in FEA simulation, because  $M_y$  depend on manually calculated inertia forces. When inertia forces were calculated, it was left decimal points after 3 digits.

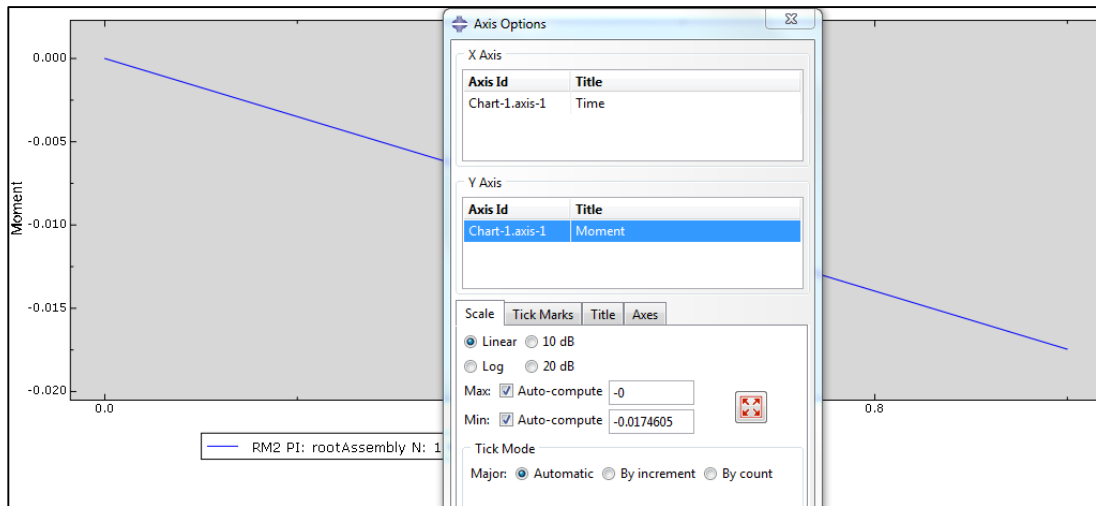

Figure 63: Reaction moment around Y axis of virtual constraint

#### **4. CONCLUSION**

Today there are lots of computer based FEA packages. They can be used to analyze various types of complex structures and geometries in static and dynamic modes. In order to carry out any kind of analysis, it is needed to provide adequate constraints to software. Else software does not run and stops the program with error command.

Most of the structure/bodies found in the natures are floating types or semi floating types and when these structure/bodies can't be analyzed by computer based FEA package directly. Hence this research introduced a method to analyze floating and semi floating type structures using concept of virtual constraints in computer based FEA packages. Under this concept of virtual constraint, no any reaction forces or moment are created on the structure by virtual constraint and hence no any interference occur to structure/body after virtual constraints are applied. This concept can be extended to dynamic system also. Then any dynamic system can be analyzed using computer based FEA package in static mode.

During the research works, first it is discussed the situation where structures or bodies have no enough fixed constraints or supports with reference to globe. Then stiffness matrix becomes singular and displacement field become ambiguous. In the other words, for the same forces and moment, displacement field has infinite solution. This situation is later verified by a three beam structure which are connected by pin joints. In mathematical modeling, it was shown that stiffness matrix is singular when the structure is non-constrained. Further this condition was justified by a constant strain triangular where stiffness matrix shows that it is singular when there are no constraints.

After that non-constrained beam which is equilibrium under equal and opposite forces was analyzed by five FEA packages which are Abaqus, Nastran, Patran, Strand7 and Solidwork simulia. All software packages gave error or warning during analysis and it indicated model was un-constrained.

In the chapter 3, concept of virtual constrained is produced and it is verified by quaternions method and static method. Then three case studies were done using concept of virtual constraints.

Under case studies, first it was analyzed a roof structure on Kulasinghe auditorium in NERD center. This roof structure is a semi-floating structure and virtual constraints were used in one end of the structure and structure was able to performed stress and strain analysis using Abaqus 6.14 package. After FEA simulation, it showed that reaction forces and moment generated due to virtual constraints are very close to zero ( $F_x$ ,  $F_z$  and  $M_y$  are .8E-8N, -2.7E-9 and -1.9E-5 respectively). But these values were not equal to absolute zero because in FE analysis software follows a numerical method and solves simultaneous equations by techniques like Gaussian elimination or Gaussian iterative method.

As second case study, rotating disc was considered and it was converted to static system by applying reversed rotary inertia force in to nodal point of discrete parts of the disc. Then disc was under equilibrium without adequate constraint and virtual constraint was given to analyses the disc in Abaqus 6.14. After analyzing, stress and strain created on the disc could be found. FE analysis gave reaction forces and moment  $F_x$ ,  $F_z$  and  $M_z$  as  $-5E - 15N$ , 0 and  $0.003Nm$  respectively.  $F_x$  and  $M_z$  are close to zero, but not equal to absolute zero because these values depend on reverse inertia forces. In the analysis, reverse inertia forces were calculated manually. Hence this manual calculation process, decimal values after 3 digits were left and it affected to reaction values.

Under third case study, rotating double wind blade was analyzed in static mode in Abaqus 6.14. When the blade rotates around rotating axis, accelerations are generated on the each elements of the wind blades and acceleration vector was derived using kinematics. Then reversed inertia forces which was obtained by multiplying element's mass with acceleration vector were applied to all the nodes of the blade. This force system make an equilibrium system and virtual constraint was given to end of the rotating shaft. After static analysis, stress generated in the wind blade can be found out. Reaction moment created due to virtual supports,  $M_y$  was given as -0.01Nm and which is equal to zero.  $M_y$  was not also absolutely zero in FEA simulation, because  $M_y$  depend on manually calculated inertia forces. When inertia forces were calculated, it was left decimal points after 3 digits.

## References

- [1] S. Timoshenko, and J., Goodier. “Plane stress and plane strain” in Theory of Elasticity, 2<sup>nd</sup> ed., New York: McGraw-Hill, 1951, pp. 22-24.
- [2] R. Janco, and B., Hucko. “Stress and strain-axial loading” in Introduction to Mechanics of Material, part 1, 1<sup>st</sup> ed., 2013, pp. 40-45.
- [3] K. Sung. “Stress and strain” in Mechanics of Solid and Fracture, 2<sup>nd</sup> ed., 2016, pp. 18-27.
- [4] B. Evgeny. “Solution of finite element equilibrium equations” in Introduction to the Finite Element Method, Riga, 2001, pp.30-60.
- [5] I. Moharas, I., Oldal, and A., Szekrenyes. “Energy theorem of elasticity, calculus of variation, finite element method, determination of stiffness equation in case of co-planer, tensed element” in Finite Element method, 2012, pp.13-63.
- [6] J. Dean, Class lecture, Topic “The direct stiffness method and stiffness matrix”, Faculty of Engineering, University of Cambridge.
- [7] D. F. M. Perera. “Theory of virtual supports” in Virtual supports for rigid foundation, Sarasavi publication, Sri Lanka, 2010, pp.16-27.
- [8] S. Lee, C. Lim and S. Kwak. “An efficient method for thermal stress analysis considering influence of displacement boundary conditions”, International journal of CAD/CAM, 2011.
- [9] P. Serdobintsev and K. Ivanyuk. “Analyzing the stress-strain state of object bodies subject to hydrostatic pressure using modern CAD system”, 2<sup>nd</sup> International Conference on Industrial Engineering, Application and Manufacturing (ICIEAM), Rusia, 2016.

- [10] Y. Kwak, H. Lim and H. Nam. “Effect of displacement boundary conditions on thermal deformation in thermal stress problem”, China foundry, 2013.
- [11] R. Tirupathi and D. Ashok. “Fundamental concept” in Introduction to Finite Elements in Engineering, 3<sup>rd</sup> ed. New Jersey, 2002, pp.1-5.
- [12] [https://en.wikipedia.org/wiki/Vacuum\\_tube](https://en.wikipedia.org/wiki/Vacuum_tube) [Oct.10,2016]
- [13] [https://en.wikipedia.org/wiki/Integrated\\_circuit](https://en.wikipedia.org/wiki/Integrated_circuit) [Oct.10, 2016]
- [14] J. Akin. “Capabilities of FEA” in Finite Element Analysis with Error Estimators, 1<sup>st</sup> ed., Burlington, 2005, pp.1-5.
- [15] P.V. Marcal. “On general programs for Finite Element Analysis, with special reference to geometric and material nonlinearities,” presented at the symposium on Numerical Solution of Partial differential equations, University of Maryland, 1970
- [16] T., Raphael, G. Zafer and P. Manohr. “Aspects of the optimization process in practice” in Element of Structural Optimization, 2<sup>nd</sup> ed., Springer-Science+Business Media, B.V,1990, pp.198-202.
- [17] Abaqus documentation 6.14, Getting started with Abaqus, interactive edition <http://130.149.89.49:2080/v6.14/> [Feb.17,2017]
- [18] Abaqus documentation 6.14, Abaqus Analysis user’s guide. <http://130.149.89.49:2080/v6.14/> [Feb.17,2017]
- [19] Abaqus documentation 6.14, Abaqus CAE user’s guide. <http://130.149.89.49:2080/v6.14/> [Feb.17,2017]
- [20] G. Liu and S. Quek. “Computational modelling” in The Finite Element Method, 1<sup>st</sup> ed. Butterworth, Heinwamm, 2003, pp.1-10.

- [21] L. Daryl. The First Course in the Finite Element Method, 4<sup>th</sup> ed., Nelson, a division of Thomson, Canada, 2007, pp.1-306.
- [22] [http://fea-cae-engineering.com/fea-engineering/element\\_types.htm](http://fea-cae-engineering.com/fea-engineering/element_types.htm)[Oct.13,2016]
- [23] Pavlou, and G., Dimitriou. "The principle of minimum potential energy for one-dimensional element" in Essentials of the finite element method for mechanical and structural engineers, London, 2015, pp 279-288.
- [24] C. Caprani. "The principle of virtual work" in Virtual work 3<sup>rd</sup> year structural Engineering, 2010/11, pp14-20.
- [25] D. Roylance. Finite Element Analysis, Department of Materials Science and Engineering Massachusetts Institute of Technology Cambridge, MA 02139, 2001, pp1-16.
- [26] P. Boeraeve. "The finite element method" in Introduction to the Finite Element Method (FEM), 2010, pp19-23.
- [27] S. Wynand. "Matrices in geometry" in Matrix Method and Differential Equations, 2012, pp50-55.
- [28] Pavlou and G. Dimitriou. "The Principle of Minimum potential energy for two dimensional and three-dimensional elements" in in Essentials of the finite element method for mechanical and structural engineers, London, 2015, pp 311-371.
- [29] B. James. "An introduction to the theory of determinants" in Fundamental of Linear Algebra, 2005, pp 247-251.
- [30] K. Kuttler. "determinants" in Elementary Linear Algebra, 2012, pp 99-127.
- [31] [https://en.wikipedia.org/wiki/Quaternions\\_and\\_spatial\\_rotation](https://en.wikipedia.org/wiki/Quaternions_and_spatial_rotation) [Feb.17,2017]
- [32] W.K.R., Peiris, K.Y.H.D., Shantha, S.A.P.S., Silva, and H.S., Kumarasinghe, "Analysing floating structures and dynamic systems by using the concept of virtual supports and by software in static mode".Technical sessions IESL Sri Lanka, 2015, pp 23-28.

- [33] Abaqus documentation 6.14, Abaqus example problem manual  
<http://130.149.89.49:2080/v6.14/> [Feb.17,2017]
- [34] G. Ingram. "Blade element theory" in Wind Turbine blade Analysis using the Blade Element Momentum method, Version 1.1., Durham University, pp 8-20.
- [35] M. Kany and M. El Gendy, Effect of Superstructure Rigidity on the Foundation system, January 2000, Conference: 2. Kolloquium, Bauen in Boden und Fels, Technische Akademie Esslingen, Ostfildern, Germany, 18-19 January 2000., Ostfildern, Germany
- [36] Abaqus documentation 6.14, Abaqus Theory Guide,  
<http://130.149.89.49:2080/v6.14/books/stm/default.htm?startat=ch01s05ath12.html> [Feb.17,2017]
- [37] E. Oñate, Structural Analysis with the Finite Element Method, Linear Statics. Volume 1. Basis and Solids, Springer, 2009
- [38] Liu, X., Zhang, L. "Structural Theory." Bridge Engineering Handbook. Ed. Wai-Fah Chen and Lian Duan Boca Raton: CRC Press, 2000



## Appendix

When the wind blade is at any position in the space, acceleration of any point in global X,Y and Z directions are derived here.

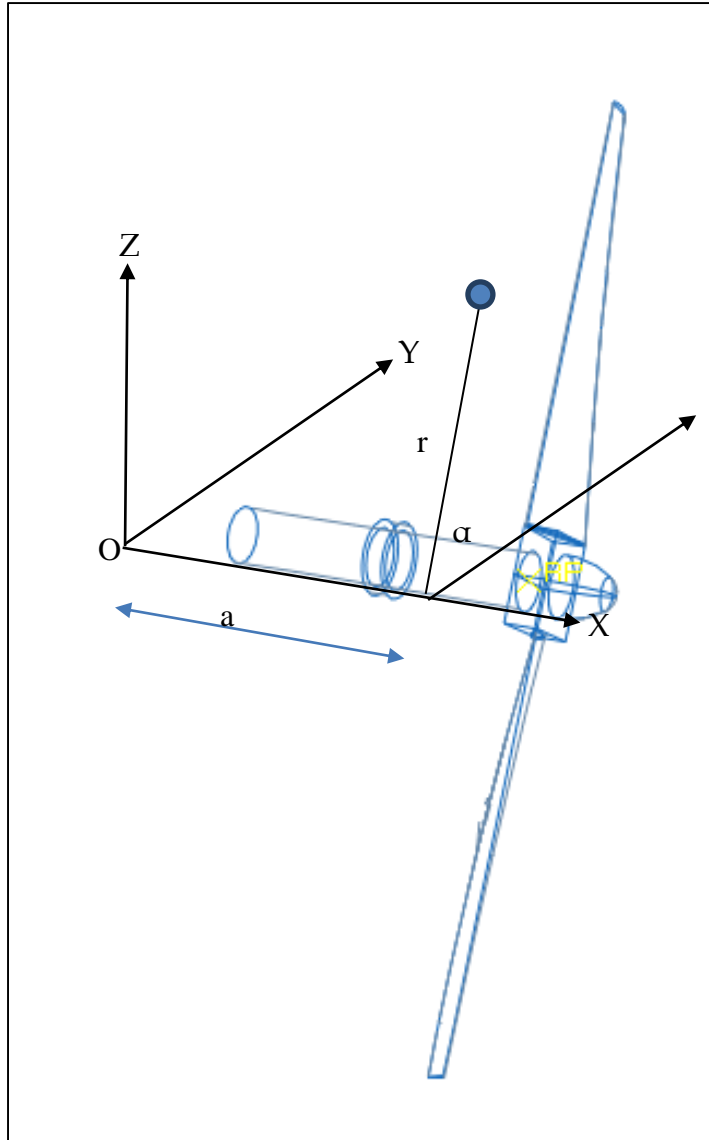

Figure 64: Kinematics on wind blade

$$X = a$$

$$y = r \cos \alpha$$

$$z = r \sin \alpha$$

$$\ddot{y} = -r(-\ddot{\alpha} \sin \alpha - \dot{\alpha}^2 \cos \alpha)$$

$$\ddot{z} = \ddot{\alpha} r \cos \alpha - \dot{\alpha}^2 r \sin \alpha$$

$$r = (y^2 + z^2)^{1/2}$$

$$\alpha = \sin^{-1}\left(\frac{z}{r}\right)$$