

Reference List

- [01] Martin J. Heathcote, "The J & P Transformer Book, Reed Educational and Professional Publishing Ltd, 12th Edition, pp. 103-155, (1998)".
- [02] Luca Dalessandro, Fabiana Da Silveira, Johann W. Kolar, "Self Capacitance of High-Voltage Transformer", IEEE Transactions on Power Electronics, Vol. 22, No. 5, September 2007.
- [03] J.R. Lucas "High Voltage Testing", High Voltage Engineering, University of Moratuwa, pp. 155-158.
- [04] W. A. V. Weerawardane, H. M. Wijekoon, Ceylon Electricity Board, Sri Lanka, "Analysis of Transient Over Voltages in Medium Voltage Distribution Network of Ceylon Electricity Board, Sri Lanka".
- [05] V. B. Wijekoon, H. M. Wijekoon. "Measures To Minimize Distribution Transformer Failures in the MV Network of Ceylon Electricity Board, Sri Lanka".
- [06] M.A.K.M. Fernando, V. Cooray, "Lightning Surges at Distribution Transformer Secondary" ICIS 2010, Jul 29-Aug 01, 2010, India.
- [07] M.V. Prabhakar and S.K. Gupta "Windings and Insulation, Transformers", Bharat Heavy Electricals Limited, 02nd Edition, pp. 108-137, (2003).
- [08] Eilert Bjerkan, "High Frequency Modeling of Power Transformers, Stresses & Diagnostics", Trondheim, May 2005.
- [09] "Relative Permittivity - Dielectric Constant, Some common materials and relative permittivity", Internet article, http://www.engineeringtoolbox.com/relative-permittivity-d_1660.html.
- [10] "Dielectric Constant, Strength, & Loss Tangent", Internet article, <http://www.rfcafe.com/references/electrical/dielectric-constants-strengths.htm>.



University of Moratuwa, Sri Lanka.
Electronic Theses & Dissertations

www.lib.mut.ac.lk

- [11] “Hazard Profiles in Sri Lanka, Lightning.pdf”, Internet article, <http://www.hazard.lk/Hazard%20Profile/Lightning.pdf>, Ministry of Disaster Management, Sri Lanka, pp. 105-123.
- [12] J.R. Lucas “High Voltage Surge Generators”, High Voltage Engineering, University of Moratuwa, pp. 132-145.
- [13] Juergan Biela, and Johann W. Kolar, “Using Transformer Parasitics for Resonant Converters - A Review of the Calculation of the Stray Capacitance of Transformers”, IEEE Transactions on Industry Applications, Vol. 44, No. 1, January/February 2008.
- [14] Marjan Popov, Lou van der Sluis, Rene Peter Paul Smeets, Jose Lopez Roldan, “Analysis of Very Fast Transients in Layer Type Transformer Windings”, IEEE Transactions on Power Delivery, Vol.22, No.1, January 2007.
- [15] “Transformer Engineering Design and Practice”, Internet article, <http://203.158.253.140/media/eBook/Engineer/Electrical/Transformer%20Engineering%20-%20Design%20and%20Practice/DK1232ch7.pdf>, pp. 277-325.
- [16] “Aluminium Foil”, Internet article, http://en.wikipedia.org/wiki/Aluminium_foil.
- [17] “Advent Research Materials, Aluminum Foils”, Internet article, <http://www.adventrm.com/catalogue/lines.aspx?criteria=materialform&materialid=2&formid=4>.
- [18] “Good fellow On-line Interacting Catalog”, Internet article, http://www.goodfellow.com/catalogue/GFCat4.php?ewd_token=3HaNjvvV0GzaEckGCmpUUtd7Bvawv2&n=aWksCOntG4bc17SBXRhIQI0cFILQ1v.
- [19] “Solenoid”, Internet article, <http://en.wikipedia.org/wiki/Solenoid>.
- [20] J.R. Lucas “Electromagnetic Theory”, University of Moratuwa, pp. 6-7.

Appendix A: Simulation circuit for a HV winding having a fully filled outermost layer without shield

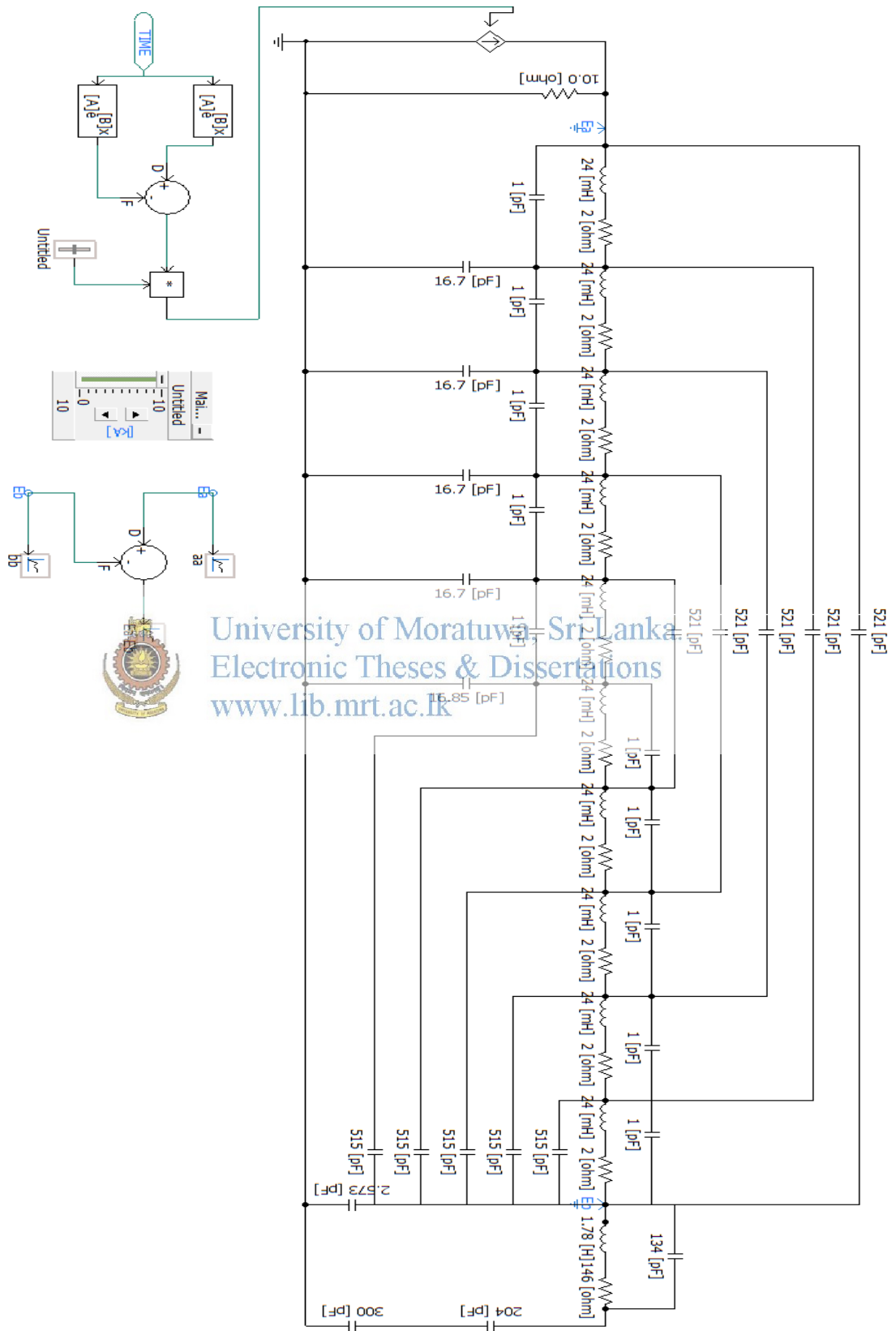

Appendix B: Simulation circuit for a HV winding having a fully filled outermost layer with shield

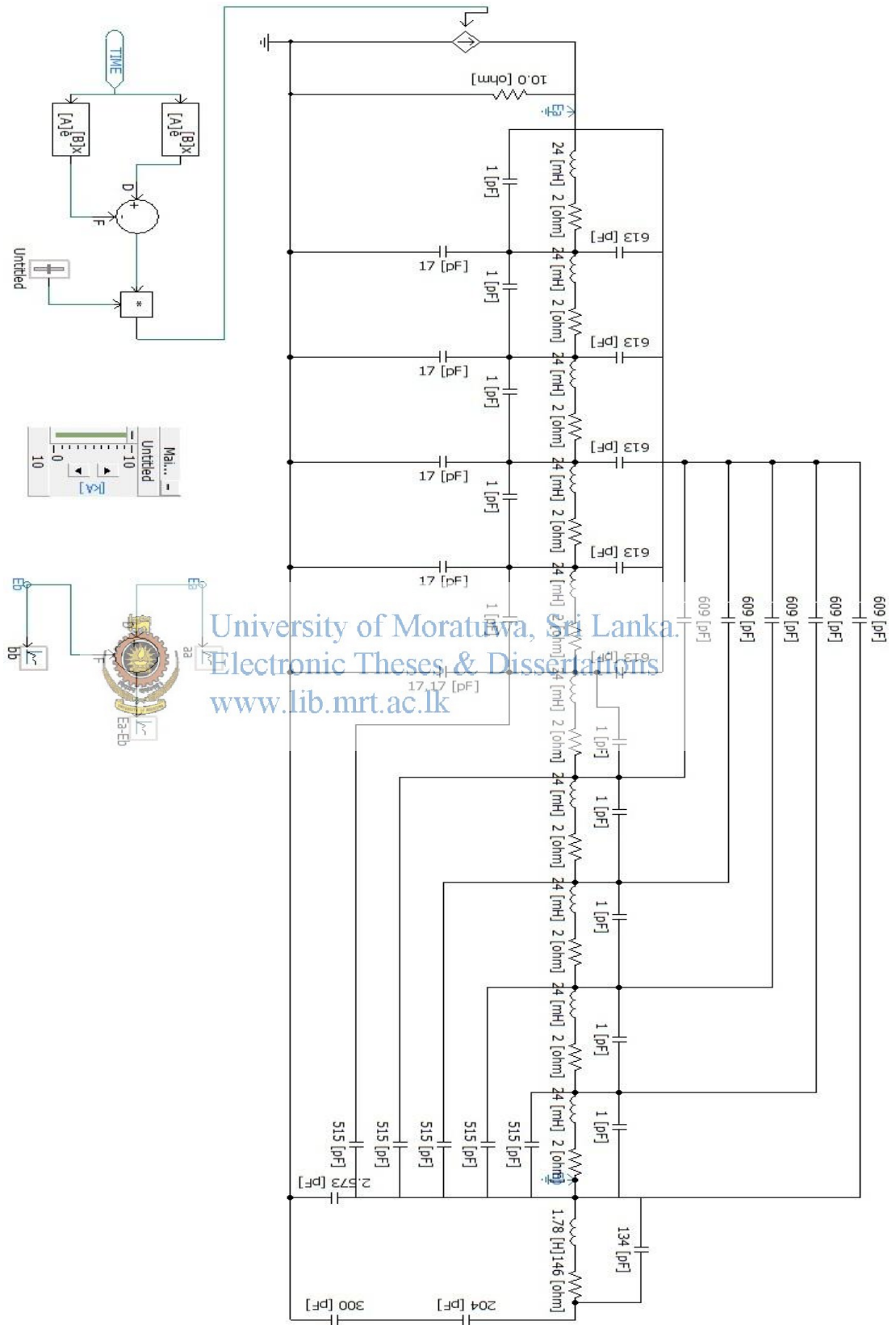

Appendix C: Simulation circuit for a HV winding having a partially filled outermost layer without shield

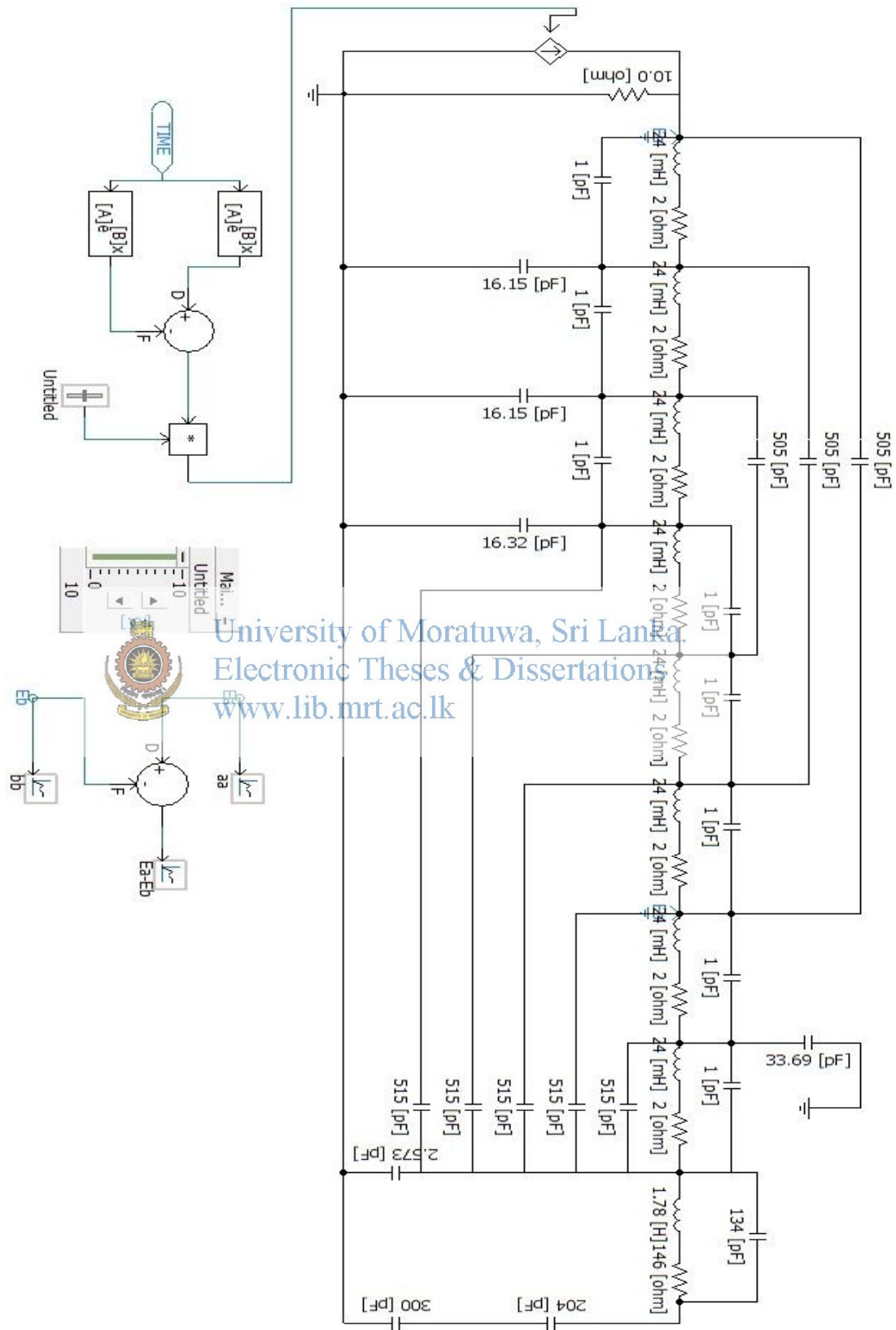

Appendix D: Simulation circuit for a HV winding having a partially filled outermost layer with shield

